

REVISIONS					
#	LN	DESCRIPTION	DATE	EN	APPD
G		LOGO CHANGE	07APR2013	QL	KZ

MECHANICAL:

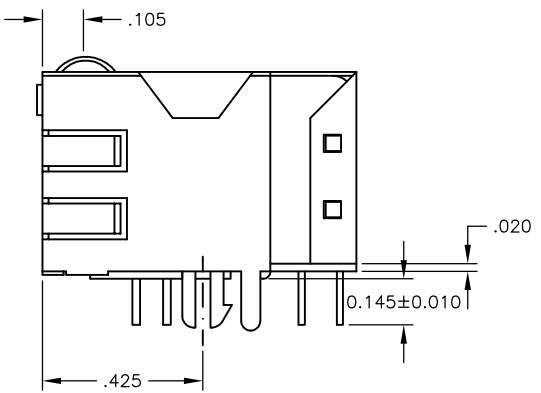

- △ MATERIALS:
HOUSING - THERMOPLASTIC PET POLYESTER FLAMMABILITY RATING UL 94V-0.
SHIELD - .010" THICK, C26800 BRASS PREPLATED WITH 30μINCH MIN SEMI-BRIGHT NICKEL. SOLDER TABS POST DIPPED WITH 100μINCH MIN SAC SOLDER.
MOD JACK CONTACTS - 0.0157 X 0.018" PHOSPHOR BRONZE, 50μINCH MIN OVERALL NICKEL UNDERPLATE WITH SELECT 50μINCH MIN HARD GOLD FINISH PLATE.
SOLDERTAILS WITH 100μINCH MIN MATTE TIN AND/OR SAC SOLDER DIP.
LIGHT EMITTING DIODE(LED) - DIFFUSED EPOXY LENS, .020" X .020" CARBON STEEL WIREFRAME LEADS PRE-PLATED WITH 80μINCH SILVER OVER 40μINCH NICKEL UNDERPLATE OVER 40μINCH COPPER UNDERPLATE. POST-PLATED WITH 100μINCH MIN MATTE TIN AND/OR SAC SOLDER DIP OR PURE TIN SOLDER DIP.
- △ RJ45 JACK CAVITY CONFORMS TO FCC RULES AND REGULATIONS PART 68, SUB PART F.
- △ MAGNETICS
-APPLICATION: 10/100 BASE-T
-IMPEDANCE: 100 OHMS
-TURNS RATIO (CHIP:CABLE): TX = 1:1.41, RX = 1:1
-OPEN CIRCUIT INDUCTANCE (OCL): 350μH MIN @100kHz, 0.1VRMS, 8mADC BIAS FROM 0°C TO 70°C, TX AND RX
-PERFORMANCE @ 25°C:
 INSERTION LOSS (IL): 1.1dB MAX FROM 0.5MHz TO 100MHz
 RETURN LOSS (RL): 18dB MIN FROM 0.5MHz TO 30MHz
 18-20LOG(f/30)dB MIN FROM 30.1MHz TO 60MHz
 12dB MIN FROM 60.1MHz TO 80MHz
 CROSSTALK ATTENUATION: 35dB MIN FROM 0.5MHz TO 40MHz
 33-20LOG(f/50)dB MIN FROM 40.1MHz TO 100MHz
 COMMON MODE REJECTION RATIO (CMRR): 30dB MIN FROM 0.5MHz TO 100MHz
-ISOLATION VOLTAGE:2250VDC (MAX) FOR 60 SECONDS WITH A RISE TIME OF 500V/SEC.
- 4 OPERATING TEMPERATURE: FROM 0°C TO +70°C.

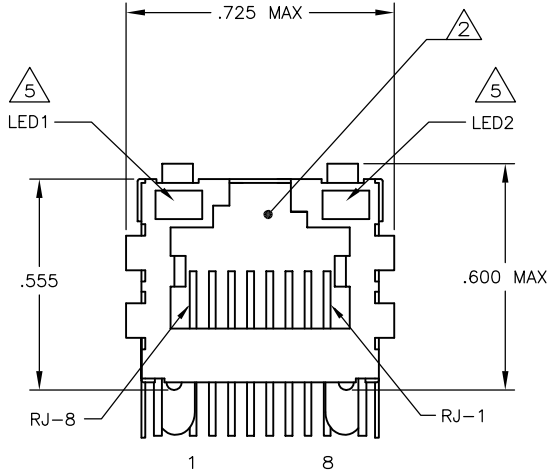
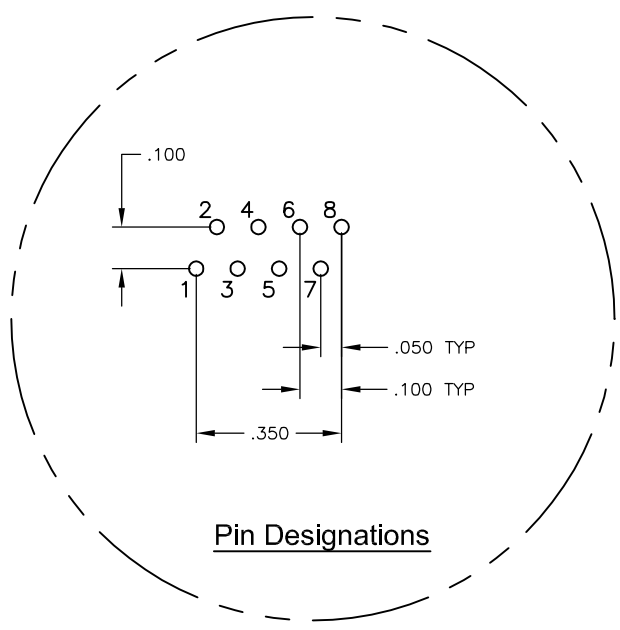
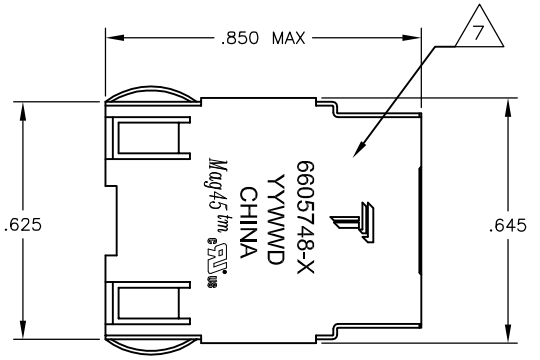
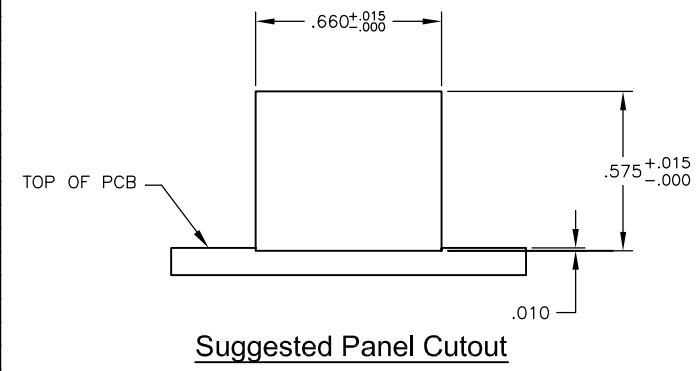

722 SERIES MAGNETIC CIRCUIT

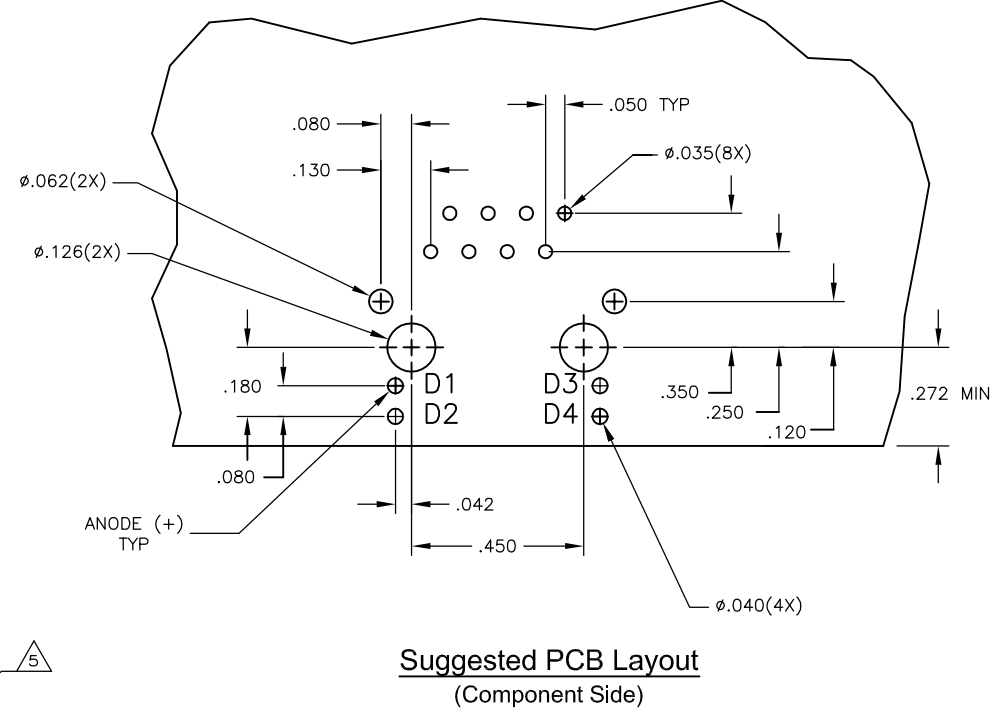
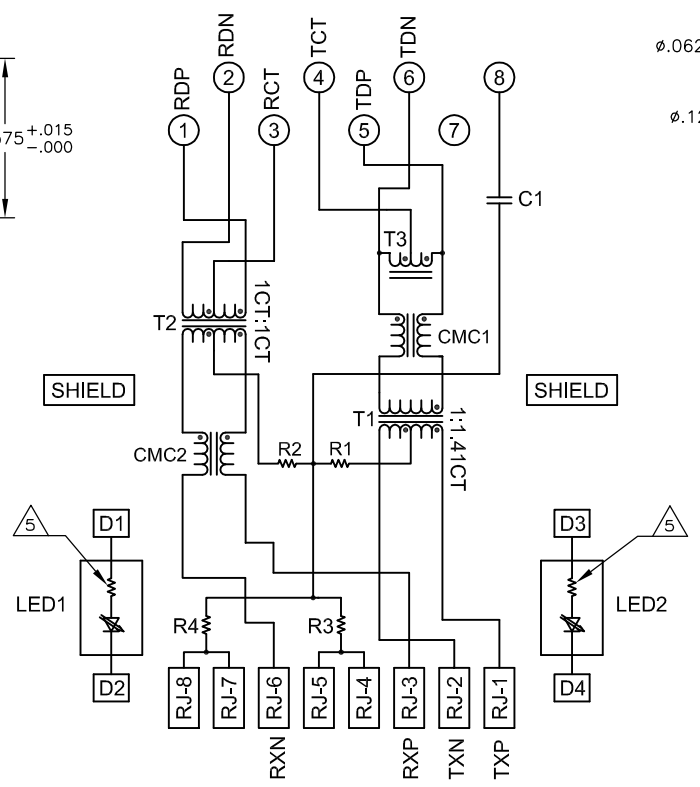

- △ THE 250 OHM RESISTOR IS OPTIONAL, PLEASE SEE CHART FOR PRESENCE OR ABSENCE OF LED RESISTORS.
IF LEDS WITHOUT 250 OHM RESISTOR, LEDS ARE DRIVEN WITH CONSTANT CURRENT AT APPROX 20 mA
LED COLOR: DOMINANT WAVELENGTH (AD): GREEN 568 nm TYP @ IF=20 mA
FORWARD VOLTAGE (VF): GREEN 2.2V TYP @ IF=20 mA
DOMINANT WAVELENGTH (AD): YELLOW 588 nm TYP @ IF=20 mA
FORWARD VOLTAGE (VF): YELLOW 2.1V TYP @ IF=20 Ma
IF LEDS WITH BUILT-IN RESISTOR, LEDS ARE DRIVEN WITH 5V VOLTAGE AND THE MAX OPERATING CURRENT IS 20mA.
LED COLOR: DOMINANT WAVELENGTH (AD): GREEN 568 nm TYP @ VF=5V
FORWARD CURRENT (IF): GREEN 12mA TYP @ VF=5V
DOMINANT WAVELENGTH (AD): YELLOW 588 nm TYP @ VF=5V
FORWARD CURRENT (IF): YELLOW 13mA TYP @ VF=5V
- △ INDICATED CONNECTIONS ARE FOR NIC CONFIGURATION. THE MAGNETICS ARE ASYMMETRIC, AND DO NOT SUPPORT AUTO-MDI/MDIX.
- △ TRP CONNECTOR LOGO, PART NUMBER, DATE CODE, COUNTRY OF ORIGIN AND AGENCY APPROVAL MARKING IN APPROXIMATE LOCATION SHOWN.
- 8. THESE PARTS ARE RECOMMENDED FOR WAVE SOLDERING PROCESS, PREHEAT TEMPERATURE IS 120°C TO 160°C, 120 SECONDS TO 180 SECONDS, PEAK WAVE SOLDERING TEMPERATURE IS 260°C MAX, 10 SECONDS MAX.
- △ OBSOLETE PARTS: OBSOLETE CIS STREAMLINING PER D.RENAUD/D.SINISI

C1 = 1000 pF, 2kV CAPACITOR
R1-R4 = 75 OHMS, 1/16 W, RESISTORS

△ OBSOLETE	YES	YES	GREEN	GREEN	6-6605748-1
△ OBSOLETE	NO	YES	YELLOW	GREEN	5-6605748-9
△ OBSOLETE	YES	YES	GREEN	YELLOW	5-6605748-1
△ OBSOLETE	NO	NO	GREEN	GREEN	1-6605748-1
△ OBSOLETE	NO	NO	GREEN	YELLOW	6605748-1

250 OHM RESISTOR	DECOUPLING CAPACITOR	LED1	LED2	PART NUMBER
------------------	----------------------	------	------	-------------

THIS DRAWING IS A CONTROLLED DOCUMENT.		DRN: G. ATTADIA - DOCK5	TRP connector
DIMENSIONS: INCHES		CHK: D. FAROLE	Dongguan China
TOLERANCES UNLESS OTHERWISE SPECIFIED:		APPD: D. FAROLE	
0 PLC	± .005	PRODUCT SPEC	NAME: 1X1 MAG45(TM), MODULAR JACK, 7N4 SCHEMATIC, 722 SERIES CIRCUIT, SHIELDED, OPTIONAL DECOUPLING CAPACITOR, WITH LEDS
1 PLC	± .010	APPLICATION SPEC	SIZE: 108-2100
2 PLC	± .015		RESTRICTED TO
3 PLC	± .020		
4 PLC	± .025		
ANGLES	± .005		
FINISH	± .005		
MATERIAL		WEIGHT	
CUSTOMER DRAWING		SCALE: 1:1	SHEET 1 OF 1 REV G