

REVISIONS				
REV	DATE	BY	APP'D	DESCRIPTION
D	23APR2013	JC	KZ	LOGO CHANGE

MECHANICAL:

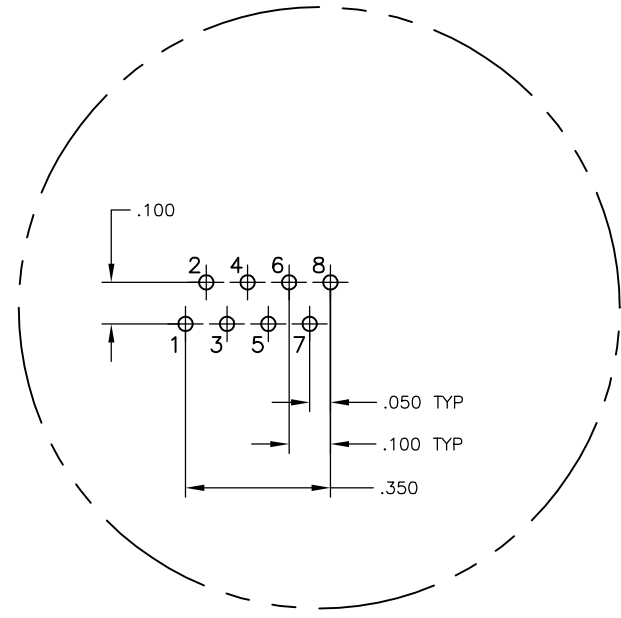
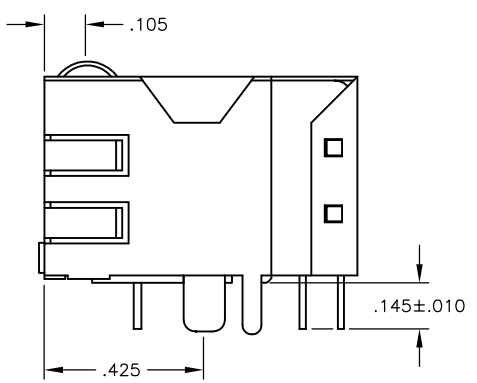
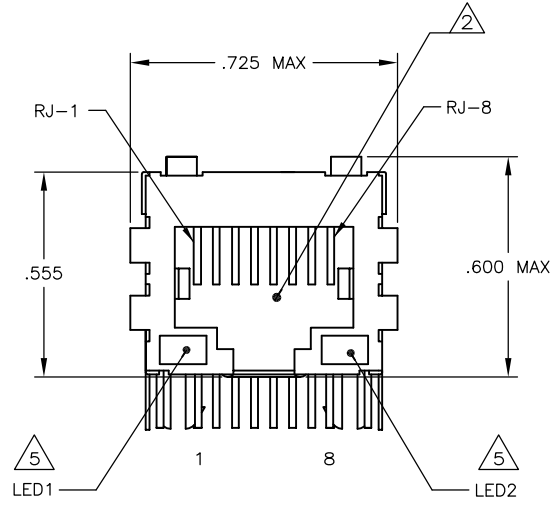
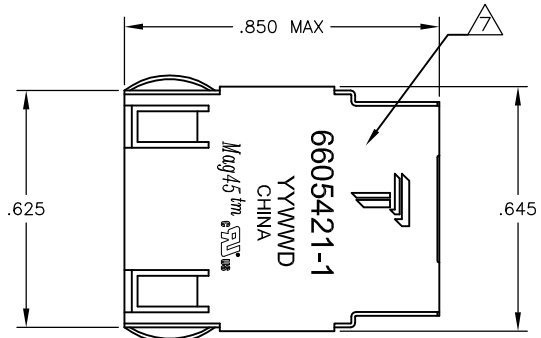

Pin Designations

MATERIALS:
 HOUSING - THERMOPLASTIC PET POLYESTER FLAMMABILITY RATING UL 94V-0.
 SHIELD - .010" THICK, C26800 BRASS PREPLATED WITH 30μINCH MIN SEMI-BRIGHT NICKEL. SOLDER TABS POST DIPPED WITH 100μINCH MIN SAC SOLDER.
 MOD JACK CONTACTS - 0.0157 X 0.018" PHOSPHOR BRONZE, 50μINCH MIN OVERALL NICKEL UNDERPLATE WITH SELECT 50μINCH MIN HARD GOLD FINISH PLATE.
 SOLDER TAILS WITH 100μINCH MIN MATTE TIN AND/OR SAC SOLDER DIP.
 LIGHT EMITTING DIODE(LED) - DIFFUSED EPOXY LENS, .020" X .020" CARBON STEEL WIREFRAME LEADS PRE-PLATED WITH 80μINCH SILVER OVER 40μINCH NICKEL UNDERPLATE OVER 40μINCH COPPER UNDERPLATE. POST-PLATED WITH 100μINCH MIN MATTE TIN AND/OR SAC SOLDER DIP OR PURE TIN SOLDER DIP.

RJ45 JACK CAVITY CONFORMS TO FCC RULES AND REGULATIONS PART 68, SUB PART F.

MAGNETICS
 -APPLICATION: 10 BASE-T
 -IMPEDANCE: 100 OHMS
 -TURNS RATIO (CHIP:CABLE): TX = 1:2.5 RX = 1:1
 -TRANSMIT OPEN CIRCUIT INDUCTANCE (OCL): 14.0μH MIN @ 100kHz, 0.1VRMS
 -LEAKAGE INDUCTANCE (LL): 0.30μH MAX @ 100kHz, 0.1VRMS
 -INTERWINDING CAPACITANCE (CWW): 15pF MAX @ 100kHz, 0.1VRMS
 -ISOLATION VOLTAGE: 2250VDC (MAX) FOR 60 SECONDS WITH A RISE TIME OF 500V/SEC.

4. OPERATING TEMPERATURE: FROM 0°C TO +70°C.

LEDS ARE DRIVEN WITH CONSTANT CURRENT AT APPROX 20 mA
 THE 250 OHM RESISTOR IS INCLUDED IN THE LEDS.
 LED COLOR: DOMINANT WAVELENGTH (λD): GREEN 568 nm TYP @ IF=20 mA
 FORWARD VOLTAGE (VF): GREEN 2.2V TYP @ IF=20 mA
 DOMINANT WAVELENGTH (λD): YELLOW 588 nm TYP @ IF=20 mA
 FORWARD VOLTAGE (VF): YELLOW 2.1V TYP @ IF=20 mA

INDICATED CONNECTIONS ARE FOR NIC CONFIGURATION.

TRP CONNECTOR LOGO, PART NUMBER, DATE CODE, COUNTRY OF ORIGIN AND AGENCY APPROVAL MARKING IN APPROXIMATE LOCATION SHOWN.

8. THE PART IS RECOMMENDED FOR WAVE SOLDERING PROCESS, PREHEAT TEMPERATURE IS 120°C TO 160°C, 120 SECONDS TO 180 SECONDS, PEAK WAVE SOLDERING TEMPERATURE IS 260°C MAX, 10 SECONDS MAX.

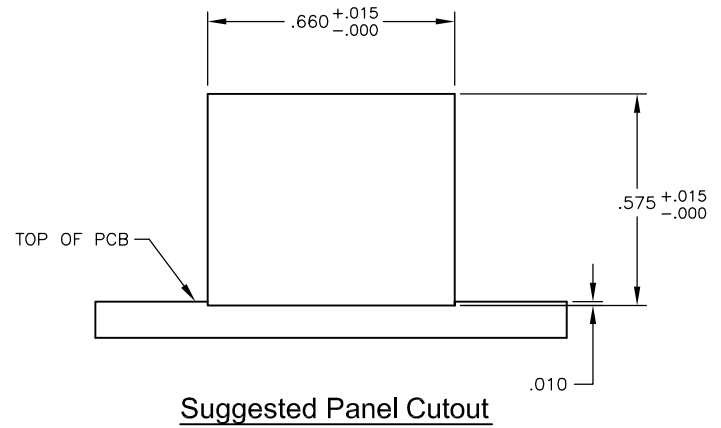

Suggested Panel Cutout

ELECTRICAL:
 424 SERIES MAGNETIC CIRCUIT

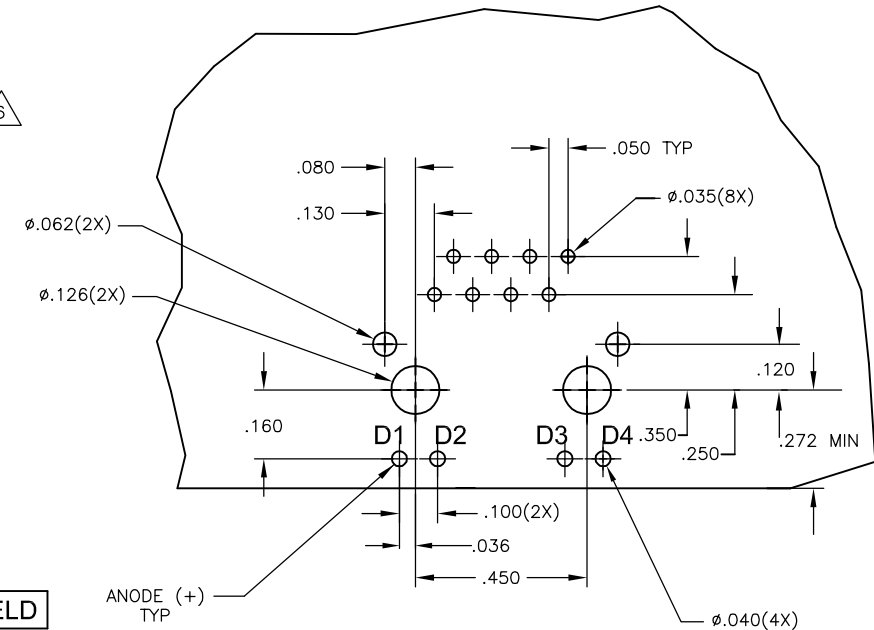
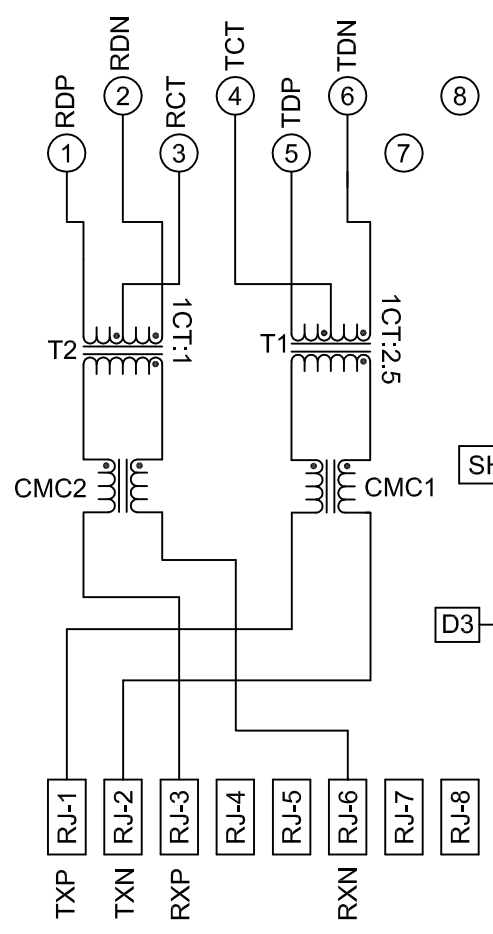

Suggested PCB Layout (Component Side)

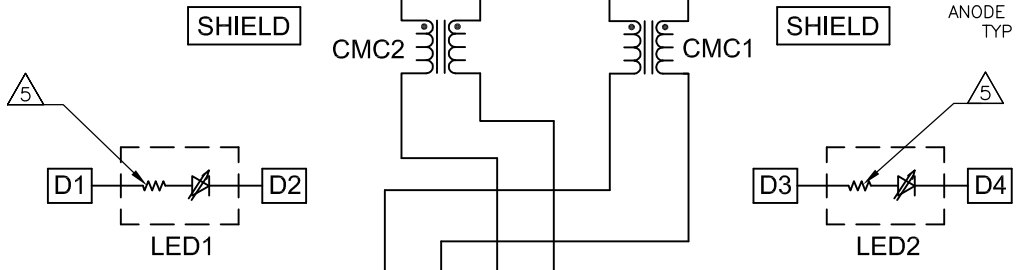

GREEN	YELLOW	6605421-1
LED1	LED2	PART NUMBER

THIS DRAWING IS A CONTROLLED DOCUMENT.		REV: G. ATTADIA - DOCK5	DATE: 08MAR2005	BY: D. FAROLE	DATE: 08MAR2005	APP'D: D. FAROLE	DATE: 08MAR2005	TRP connector Dongguan China
DIMENSIONS:	TOLERANCES UNLESS OTHERWISE SPECIFIED:	PRODUCT SPEC		NAME		1X1 MAC45(TM), 4N3 10BASE-T ETHERNET SCHEMATIC, 424 MAGNETIC CIRCUIT, SHIELDED, WITH RESISTOR LEDS		
INCHES	0 PLC ± -	1 PLC ± .010	2 PLC ± .010	3 PLC ± .005	4 PLC ± -	ANGLES	SCALE	RESTRICTED TO
							A1	
MATERIAL	FINISH	WEIGHT	CAGE CODE	DRAWING NO	SCALE	SHEET	1 OF 1	REV
				C=6605421	NTS			D
CUSTOMER DRAWING								