

REVISIONS					
#	LR	DESCRIPTION	DATE	EN	APP
F		LOGO CHANGE	23APR2013	JC	KZ

MECHANICAL:

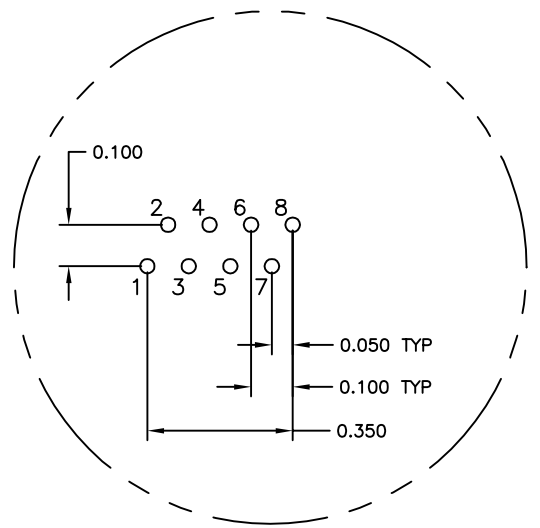
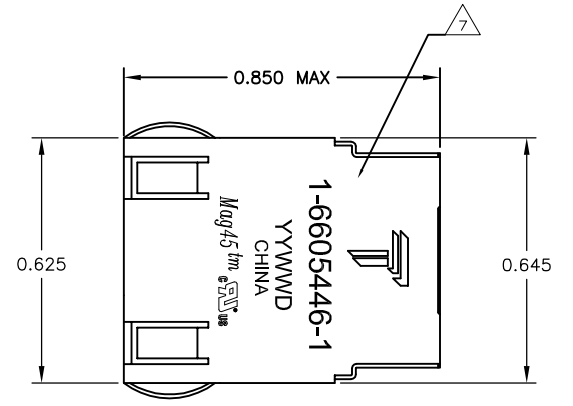

Pin Designations

△ HOUSING - THERMOPLASTIC PET POLYESTER FLAMMABILITY RATING UL 94V-0. SHIELD - .010" THICK, C26800 BRASS PREPLATED WITH 30μINCH MIN SEMI-BRIGHT NICKEL. SOLDER TABS POST DIPPED WITH 100μINCH MIN SAC SOLDER. MOD JACK CONTACTS - 0.0157 X 0.018" PHOSPHOR BRONZE, 50μINCH MIN OVERALL NICKEL UNDERPLATE WITH SELECT 50μINCH MIN HARD GOLD FINISH PLATE. SOLDER TAILS WITH 100μINCH MIN MATTE TIN AND/OR SAC SOLDER DIP. LIGHT EMITTING DIODE(LED) - DIFFUSED EPOXY LENS, .020" X .020" CARBON STEEL WIREFRAME LEADS PRE-PLATED WITH 80μINCH SILVER OVER 40μINCH NICKEL UNDERPLATE OVER 40μINCH COPPER UNDERPLATE. POST-PLATED WITH 100μIN MIN MATTE TIN AND/OR SAC SOLDER DIP OR PURE TIN SOLDER DIP.

△ RJ45 JACK CAVITY CONFORMS TO FCC RULES AND REGULATIONS PART 68, SUB PART F.

△ MAGNETICS
 -IMPEDANCE: 100 OHMS
 -TURNS RATIO (CHIP: CABLE): TX = 1:1, RX = 1:1
 -OPEN CIRCUIT INDUCTANCE (OCL): 350μH MIN @100kHz, 0.1VRMS, 8mADC BIAS FROM -40°C TO +85°C, TX AND RX
 -PERFORMANCE @ 25°C:
 INSERTION LOSS (IL): 1.1dB MAX FROM 0.5MHz TO 100MHz
 RETURN LOSS (RL): 18dB MIN FROM 0.5MHz TO 30MHz
 18-20LOG(f/30)dB MIN FROM 30.1MHz TO 60MHz
 12dB MIN FROM 60.1MHz TO 80MHz
 CROSSTALK ATTENUATION: 35dB MIN FROM 0.5MHz TO 40MHz
 33-20*LOG(f/50)dB MIN FROM 40.1MHz TO 100MHz
 COMMON MODE REJECTION RATIO (CMRR): 30dB MIN FROM 0.5MHz TO 100MHz
 -ISOLATION VOLTAGE: 2250VDC (MAX) FOR 60 SECONDS WITH A RISE TIME OF 500V/SEC.

4. OPERATING TEMPERATURE: FROM -40°C - +85°C

△ LEDS WITH BUILT-IN RESISTOR
 LEDS ARE DRIVEN WITH 5V VOLTAGE AND THE MAX OPERATING CURRENT IS 20mA.
 LED COLOR: DOMINANT WAVELENGTH (λD): GREEN 568 nm TYP @ VF=5V
 FORWARD CURRENT (IF): GREEN 12mA TYP @ VF=5V

△ INDICATED CONNECTIONS ARE FOR NIC CONFIGURATION. THE MAGNETICS ARE SYMMETRICAL TO SUPPORT AUTO-MDI/MDIX.

△ TRP CONNECTOR LOGO, PART NUMBER, DATE CODE, COUNTRY OF ORIGIN AND AGENCY APPROVAL MARKING IN APPROXIMATE LOCATION SHOWN.

8. THE PART IS RECOMMENDED FOR WAVE SOLDERING PROCESS, PREHEAT TEMPERATURE IS 120°C TO 160°C, 120 SECONDS TO 180 SECONDS, PEAK WAVE SOLDERING TEMPERATURE IS 260°C MAX, 10 SECONDS MAX.

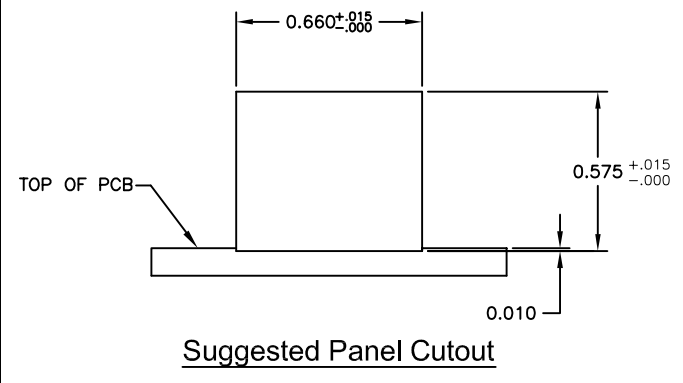
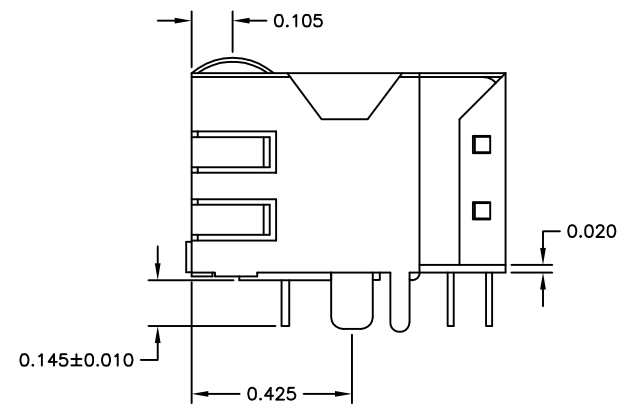
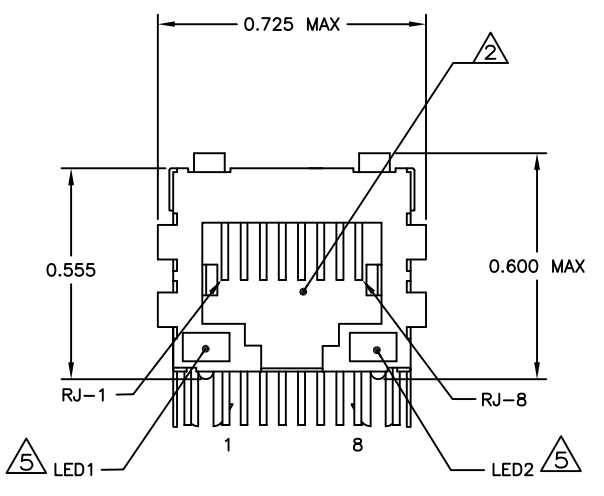

Suggested Panel Cutout

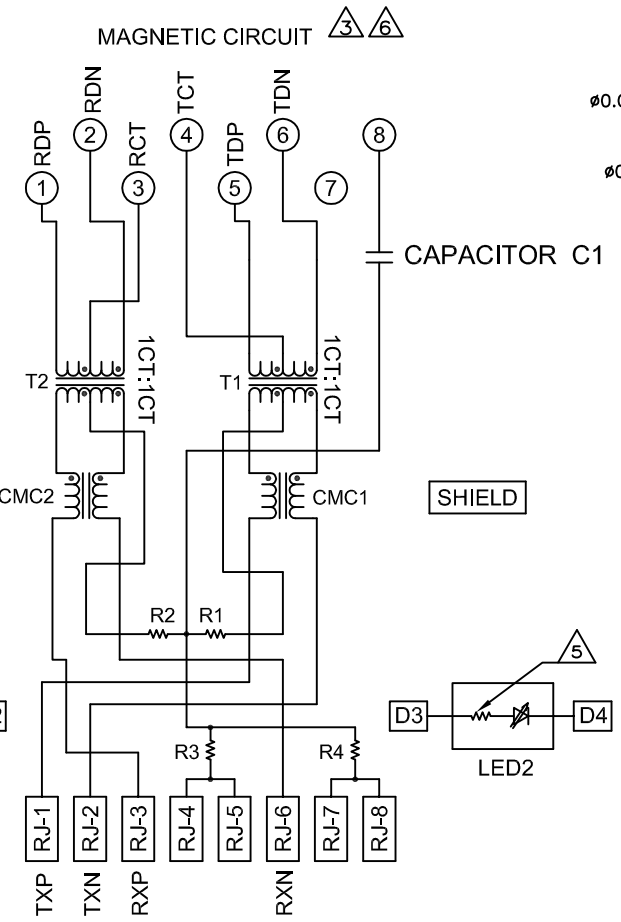

C1= 1000pF, 2KV, CAPACITOR
 R1-R4 = 75 OHMS, 1/16 W RESISTORS

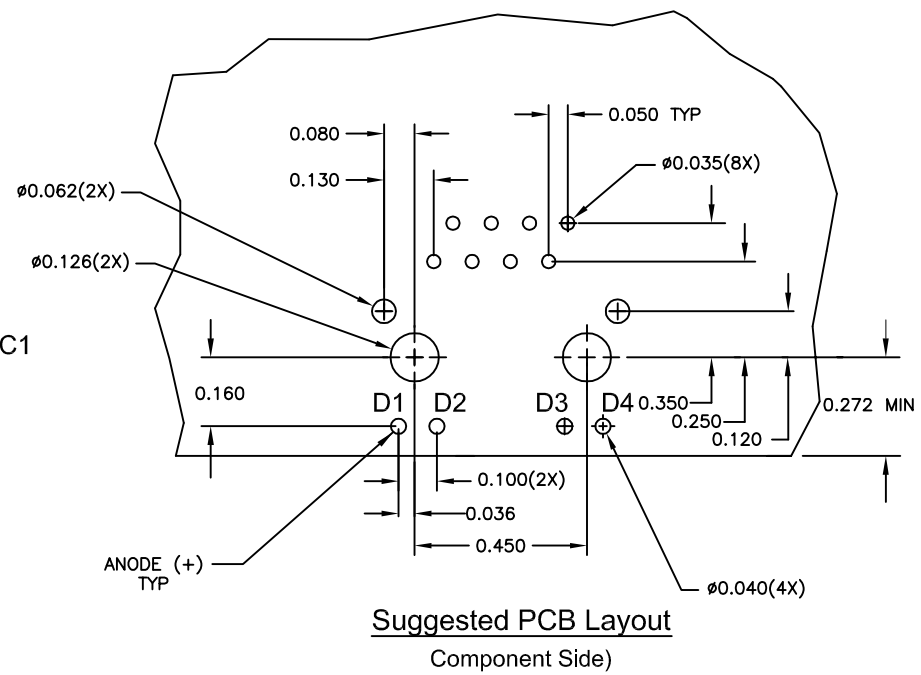

Suggested PCB Layout Component Side

WITH	GREEN	GREEN	6605446-1
WITHOUT	GREEN	GREEN	1-6605446-1
CAPACITOR C1	LED1	LED2	PART NUMBER

THIS DRAWING IS A CONTROLLED DOCUMENT.		DRN: A. FERNANDEZ-DOCKES	TRP connector	
DIMENSIONS: INCHES		CHK: D. FAROLE	Dongguan China	
TOLERANCES UNLESS OTHERWISE SPECIFIED:		APP'D: D. FAROLE	PRODUCT SPEC: 108-2100	
0 PLC	± -	APPLICATION SPEC: 108-2100		
1 PLC	± .010	SIZE: A1		
2 PLC	± .005	SCALE: NTS		
3 PLC	± .005	SHEET: 1 of 1		
4 PLC	± .005	REV: F		
ANGLES	± .005	CUSTOMER DRAWING		