

| REVISIONS | | | | |
|-----------|-----|-------------|-----------|------------|
| # | LNK | DESCRIPTION | DATE | BY / APP'D |
| D | | LOGO CHANGE | 07APR2013 | QL / KZ |

MECHANICAL:

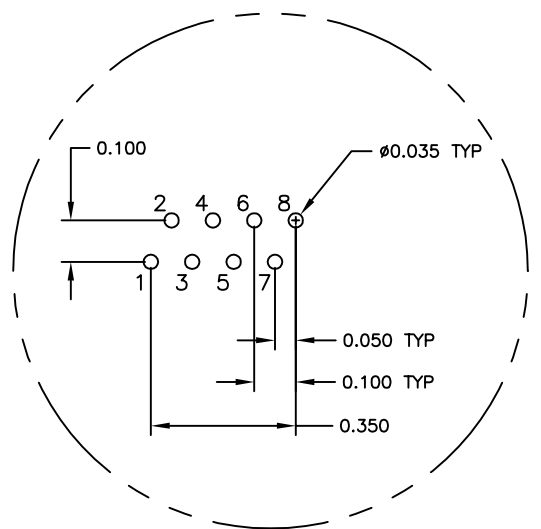

Pin Designations

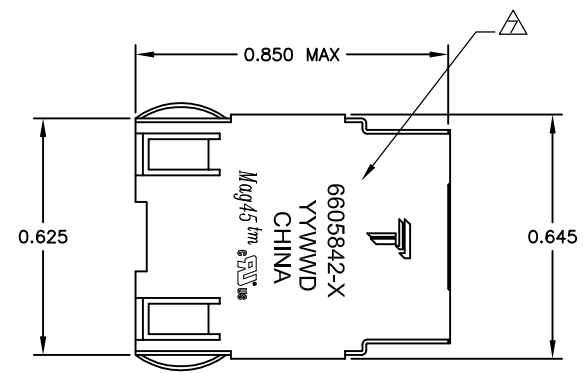
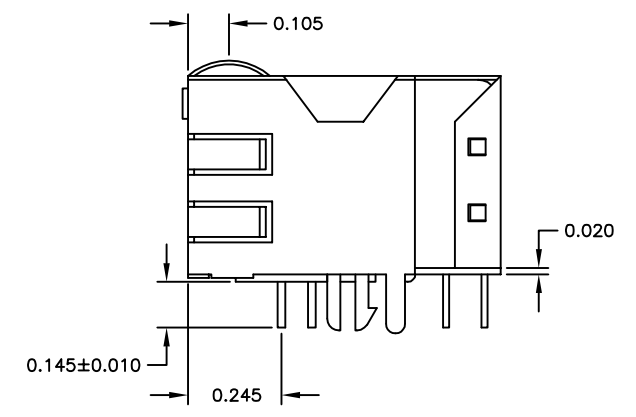
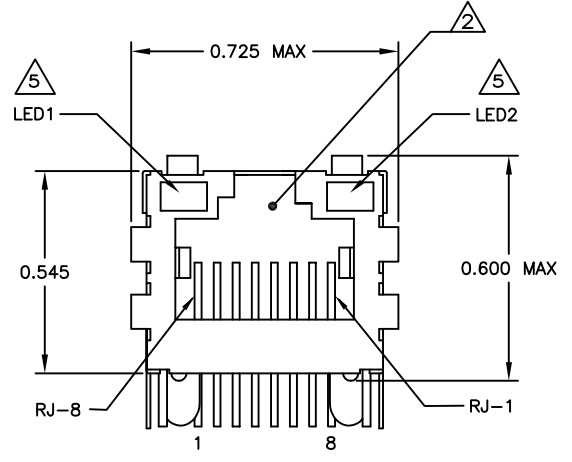

715ET SERIES MAGNETIC CIRCUIT

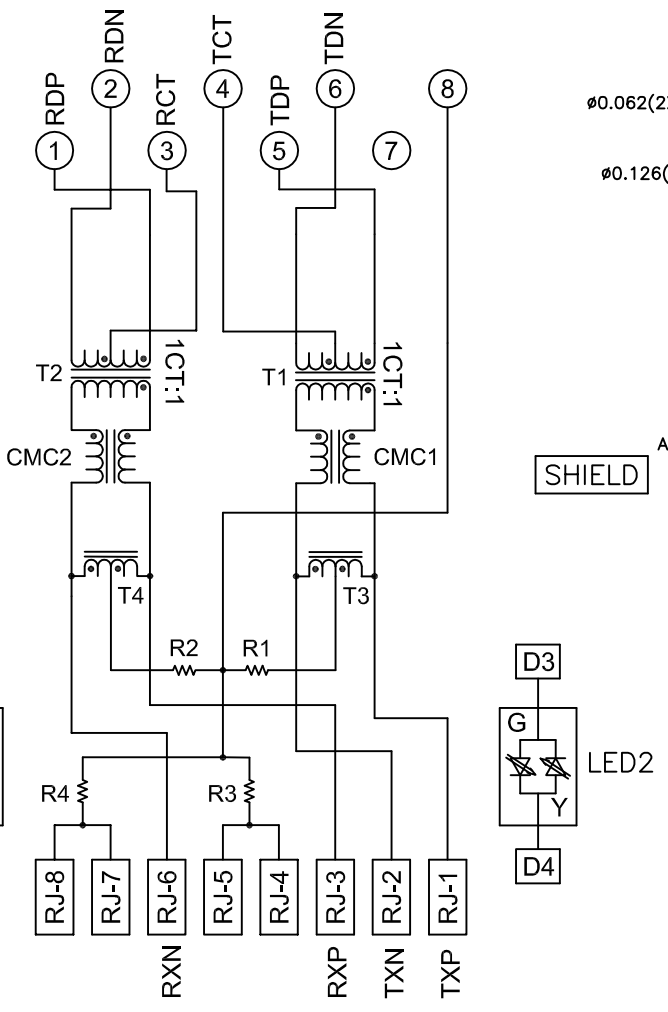

R1-R4 = 75 OHMS, 1/16 W, 5% RESISTORS

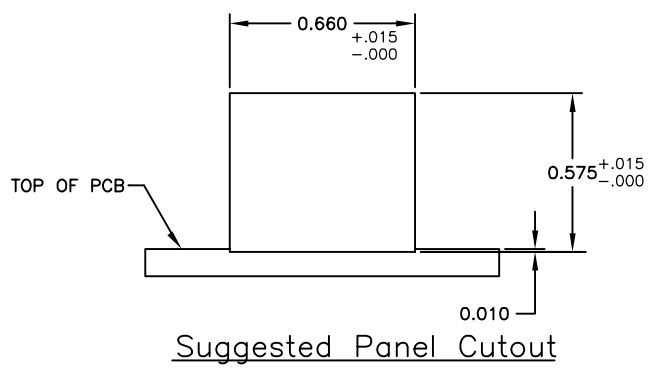

Suggested Panel Cutout

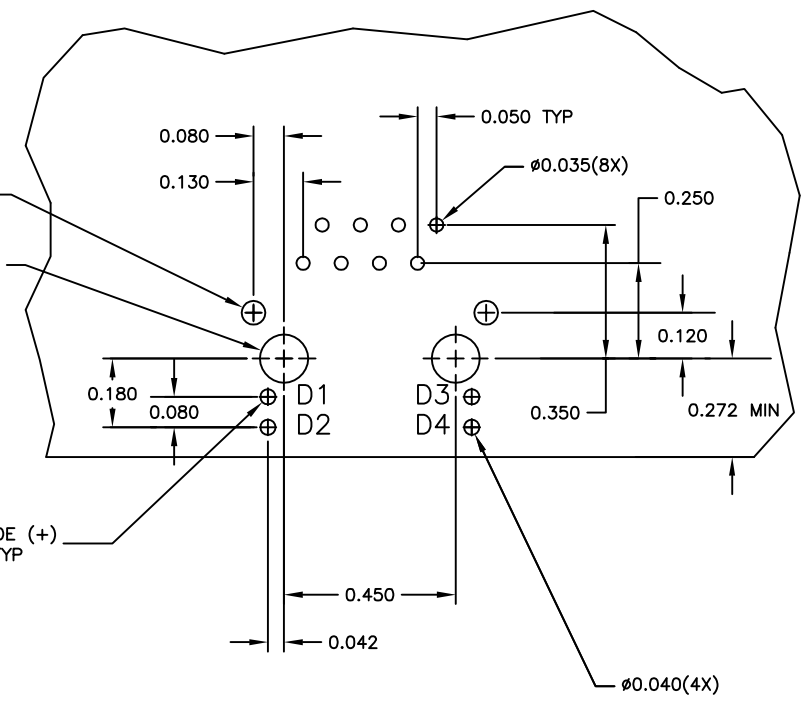

Suggested PCB Layout (Component Side)

- △ MATERIALS:
 - HOUSING - THERMOPLASTIC PET POLYESTER FLAMMABILITY RATING UL 94V-0.
 - SHIELD - .010" THICK, C26800 BRASS PREPLATED WITH 30μINCH MIN SEMI-BRIGHT NICKEL, SOLDER TABS POST DIPPED WITH 100μINCH MIN SAC SOLDER.
 - MOD JACK CONTACTS - 0.0157" x 0.018" PHOSPHOR BRONZE, 50μINCH MIN OVERALL NICKEL UNDERPLATE, WITH SELECT 50μINCH MIN HARD GOLD FINISH PLATE. SOLDER TAILS WITH 100μINCH MIN MATTE TIN AND/OR SAC SOLDER DIP.
 - LIGHT EMITTING DIODE(LED) - DIFFUSED EPOXY LENS, .020" x .020" CARBON STEEL WIREFRAME LEADS PRE-PLATED WITH 80μINCH SILVER OVER 40μINCH NICKEL UNDERPLATE OVER 40μINCH COPPER UNDERPLATE, POST-PLATED WITH 100μINCH MIN MATTE TIN AND/OR SAC SOLDER DIP OR PURE TIN SOLDER DIP.
- △ RJ45 JACK CAVITY CONFORMS TO FCC RULES AND REGULATIONS PART 68, SUB PART F.
- △ MAGNETICS
 - IMPEDANCE: 100 OHMS
 - TURNS RATIO (CHIP:CABLE): TX = 1:1, RX = 1:1
 - OPEN CIRCUIT INDUCTANCE (OCL): 350uH MIN @100kHz, 0.1VRMS, 8mADC BIAS FROM -40°C TO +85°C, TX AND RX
 - PERFORMANCE @ 25°C:
 - INSERTION LOSS (IL): 1.1dB MAX FROM 0.5MHz TO 100MHz
 - RETURN LOSS (RL): 18dB MIN FROM 0.5MHz TO 30MHz
 - 18-20LOG(f/30)dB MIN FROM 30.1MHz TO 60MHz
 - 12dB MIN FROM 60.1MHz TO 80MHz
 - CROSSTALK ATTENUATION: 35dB MIN FROM 0.5MHz TO 40MHz
 - 33-20*LOG(f/50)dB MIN FROM 40.1MHz TO 100MHz
 - COMMON MODE REJECTION RATIO (CMRR): 30dB MIN FROM 0.5MHz TO 100MHz
 - ISOLATION VOLTAGE:1500VAC (MAX) AT 60Hz FOR 60 SECS.
- 4. OPERATING TEMPERATURE: FROM -40° - +85°C
- △ LEDs WITHOUT BUILT-IN RESISTOR
 - LEDS ARE DRIVEN WITH CONSTANT CURRENT AT APPROX 20 mA
 - LED COLOR: DOMINANT WAVELENGTH (AD): GREEN 568 nm TYP @ IF=20 mA
 - FORWARD VOLTAGE (VF): GREEN 2.2V TYP @ IF=20 mA
 - DOMINANT WAVELENGTH (AD): YELLOW 588 nm TYP @ IF=20 mA
 - FORWARD VOLTAGE (VF): YELLOW 2.1V TYP @ IF=20 mA
- △ INDICATED CONNECTIONS ARE FOR NIC CONFIGURATION. THE MAGNETICS ARE SYMMETRICAL, AND THEREFORE ARE AUTO-MDI/MDIX CAPABLE.
- △ TRP CONNECTOR LOGO, PART NUMBER, DATE CODE, COUNTRY OF ORIGIN AND AGENCY APPROVAL MARKING IN APPROXIMATE LOCATION SHOWN.
- 8. THE PART IS RECOMMENDED FOR WAVE SOLDERING PROCESS, PEAK WAVE SOLDERING TEMPERATURE IS 260°C, 10SECONDS MAX.

| | | |
|--------------|--------------|-------------|
| GREEN/YELLOW | GREEN/YELLOW | 6605842-6 |
| LED1 | LED2 | PART NUMBER |

| | | | | |
|--|--------------|------------------|-----------------------|---|
| THIS DRAWING IS A CONTROLLED DOCUMENT. | | DATE: 07MAR2003 | BY: L. VARELA - DOCKS | TRP connector |
| DIMENSIONS: INCHES | | DATE: 07MAR2003 | BY: D. FAROLE | Dongguan China |
| TOLERANCES UNLESS OTHERWISE SPECIFIED: | | PRODUCT SPEC | 108-2100 | 1X1 MAC45(TM), 7N2ET INDUSTRIAL TEMPERATURE SCHEMATIC, 715 SERIES CIRCUIT, SHIELDED, NO DECOUPLING CAPACITOR, WITH LEDS |
| 0 PLC ± - | 1 PLC ± .010 | APPLICATION SPEC | SCALE: NTS | RESTRICTED TO |
| 2 PLC ± .005 | 3 PLC ± - | WEIGHT: - | SHEET 1 OF 1 | REV D |
| 4 PLC ± - | ANGLES ± - | CUSTOMER DRAWING | | |
| MATERIAL: △ | FINISH: △ | | | |