

REVISIONS				
#	LN#	DESCRIPTION	DATE	BY / APP'D
D		LOGO CHANGE	07APR2013	QL / KZ

MECHANICAL:

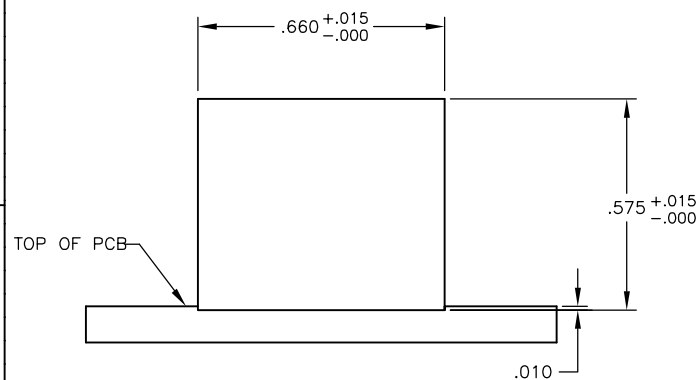
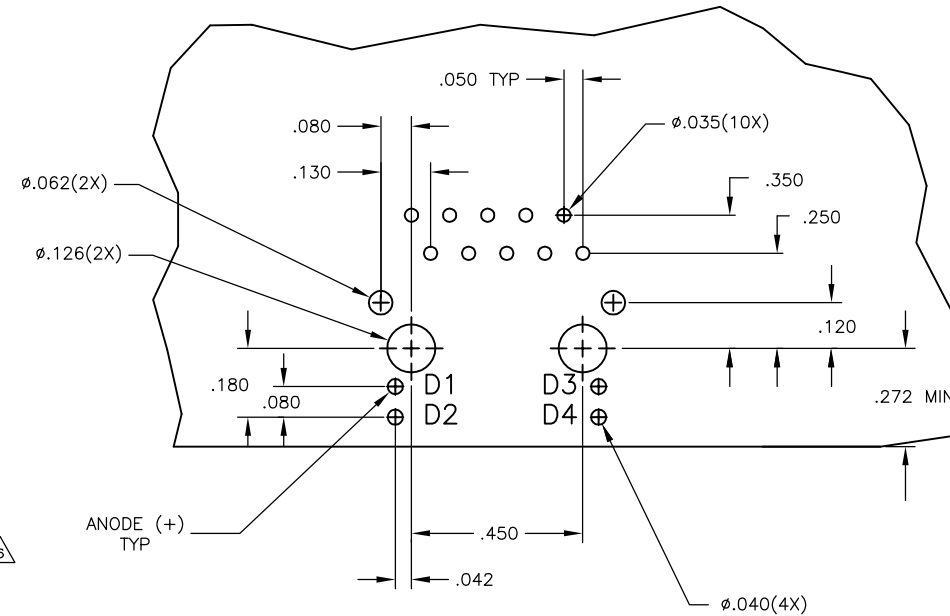
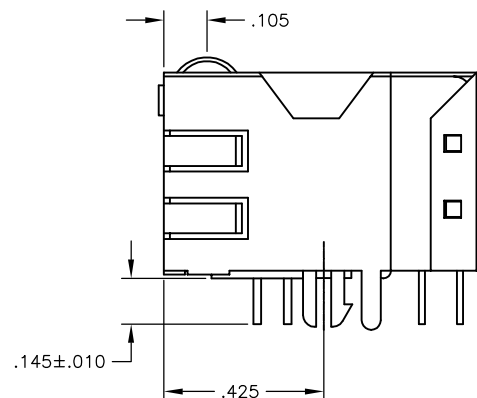
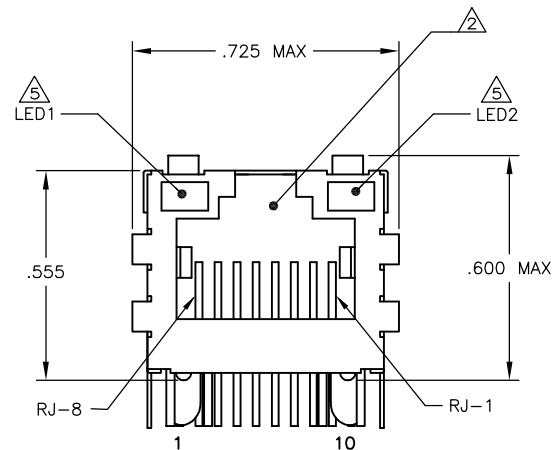
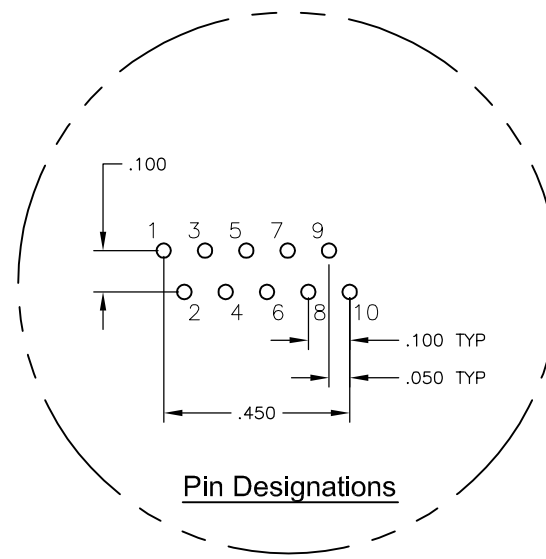
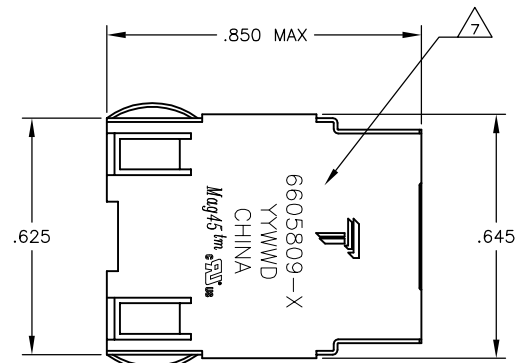

Suggested Panel Cutout

7G01 GIGABIT MAGNETIC CIRCUIT

Suggested PCB Layout (Component Side)

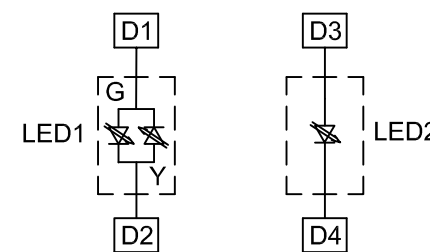
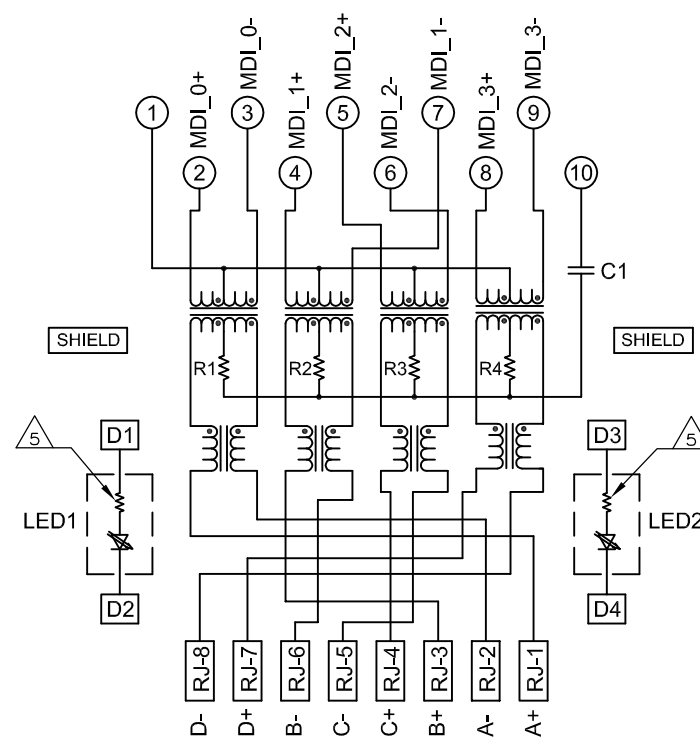

LED CONFIGURATION FOR 5-6605809-5 ONLY

C1=1000pF, 2kV CAPACITOR
R1-R4 = 75 OHMS, 1/16 W RESISTORS

- △ MATERIALS:
 - HOUSING - THERMOPLASTIC PET POLYESTER FLAMMABILITY RATING UL 94V-0.
 - SHIELD - .010" THICK, C26800 BRASS PREPLATED WITH 30µINCH MIN SEMI-BRIGHT NICKEL, SOLDER TABS POST DIPPED WITH 100µINCH MIN SAC SOLDER.
 - MOD JACK CONTACTS - 0.0157" x 0.018" PHOSPHOR BRONZE, 50µINCH MIN OVERALL NICKEL UNDERPLATE, WITH SELECT 50µINCH MIN HARD GOLD FINISH PLATE.
 - SOLDERTAILS WITH 100µINCH MIN MATTE TIN AND/OR SAC SOLDER DIP.
 - LIGHT EMITTING DIODE(LED) - DIFFUSED EPOXY LENS, .020" x .020" CARBON STEEL WIREFRAME LEADS PRE-PLATED WITH 80µINCH SILVER OVER 40µINCH NICKEL UNDERPLATE OVER 40µINCH COPPER UNDERPLATE, POST-PLATED WITH 100µINCH MIN MATTE TIN AND/OR SAC SOLDER DIP OR PURE TIN SOLDER DIP.
- △ RJ45 JACK CAVITY CONFORMS TO FCC RULES AND REGULATIONS PART 68, SUB PART F.
- △ MAGNETICS
 - IMPEDANCE: 100 OHMS
 - TURNS RATIO (CHIP:CABLE): 1:1 ALL FOUR PAIRS
 - OPEN CIRCUIT INDUCTANCE (OCL): 350µH MIN @100kHz, 0.1VRMS, 8mADC BIAS FROM 0°C TO 70°C, ALL FOUR PAIRS
 - ALL FOUR PAIRS BI-DIRECTIONAL
 - PERFORMANCE @ 25°C:
 - INSERTION LOSS (IL): 1.1dB MAX FROM 0.5MHz TO 100MHz
 - RETURN LOSS (RL): 18dB MIN FROM 0.5MHz TO 40MHz
 - 12-20LOG(f/80)dB MIN FROM 40.1MHz TO 100MHz
 - CROSSTALK ATTENUATION: 35dB MIN FROM 0.5MHz TO 40MHz
 - 33-20xLOG(f/50)dB MIN FROM 40.1MHz TO 100MHz
 - COMMON MODE REJECTION RATIO (CMRR): 30dB MIN FROM 0.5MHz TO 100MHz
 - ISOLATION VOLTAGE:2250VDC (MAX) FOR 60 SECONDS WITH A RISE TIME OF 500V/SEC.
- 4. OPERATING TEMPERATURE: FROM 0°C - +70°C.
- △ THE 250 OHM LED RESISTORS ARE OPTIONAL, PLEASE SEE CHART FOR PRESENCE OR ABSENCE OF LED RESISTORS. IF THE LED WITHOUT 250 OHM RESISTORS, LED IS DRIVEN WITH CONSTANT CURRENT AT APPROX 20mA.
 - LED COLOR: DOMINANT WAVELENGTH (AD): GREEN 568 nm TYP @ IF=20mA
 - FORWARD VOLTAGE (VF): GREEN 2.2V TYP @ IF=20mA
 - DOMINANT WAVELENGTH (AD): YELLOW 588 nm TYP @ IF=20mA
 - FORWARD VOLTAGE (VF): YELLOW 2.1V TYP @ IF=20mA.
 - IF THE LED WITH 250 OHM RESISTORS,LED IS DRIVEN WITH 5V VOLTAGE AND THE MAX OPERATING CURRENT IS 20mA.
 - LED COLOR : DOMINANT WAVELENGTH (AD): GREEN 568 nm TYP @ VF=5V
 - FORWARD CURRENT (IF): GREEN 12 mA TYP @ VF=5V
 - DOMINANT WAVELENGTH (AD): YELLOW 588 nm TYP @ VF=5V
 - FORWARD CURRENT (IF): YELLOW 13 mA TYP @ VF=5V
- △ THE MAGNETICS ARE SYMMETRICAL, AND THEREFORE ARE AUTO-MDI/MDX CAPABLE.
- △ TRP CONNECTOR LOGO, PART NUMBER, DATE CODE, COUNTRY OF ORIGIN AND AGENCY APPROVAL MARKING IN APPROXIMATE LOCATION SHOWN.
- 8. THESE PARTS ARE RECOMMENDED FOR WAVE SOLDERING PROCESS, PREHEAT TEMPERATURE IS 120°C TO 160°C, 120 SECONDS TO 180 SECONDS, PEAK SOLDERING TEMPERATURE IS 260 °C MAX, 10 SECONDS MAX.
- △ OBSOLETE PARTS: OBSOLETE CIS STREAMLINING PER D.RENAUD/D.SINISI

LED	RESISTOR	LED1	LED2	PART NUMBER
GREEN	YES	GREEN	YES	6-6605809-1
YELLOW	NO	GREEN	NO	5-6605809-9
GREEN	NO	GREEN	NO	5-6605809-7
GREEN/YELLOW	NO	GREEN	NO	5-6605809-5
YELLOW	YES	GREEN	YES	5-6605809-2
GREEN	YES	YELLOW	YES	5-6605809-1

THIS DRAWING IS A CONTROLLED DOCUMENT.

DIMENSIONS: INCHES 0 PLC ± - 1 PLC ± .010 3 PLC ± .005 4 PLC ± - ANGLES FINISH	TOLERANCES UNLESS OTHERWISE SPECIFIED: 0 PLC ± - 1 PLC ± .010 3 PLC ± .005 4 PLC ± - ANGLES FINISH	DATE: 02MAR2005 BY: D. FAROLE APPROVED: D. FAROLE PRODUCT SPEC: 108-2100 APPLICATION SPEC: WEIGHT: CUSTOMER DRAWING	TRP connector Dongguan China NAME: 1X1 MAG45(TM), 7G1 SCHEMATIC, 7G01 GIGABIT MAGNETIC CIRCUIT (10 PIN HORIZ), SHIELDED, DECOUPLING CAPACITOR, WITH LEDS SIZE: A1 DRAWING NO: 00779 PART NO: 6605809 SCALE: NTS SHEET: 1 OF 1 REV: D
---	--	---	--