

REVISIONS				
P	LTR	DESCRIPTION	DATE	OWN APVD
C		LOGO CHANGE	07APR2013	PP KZ

MECHANICAL:

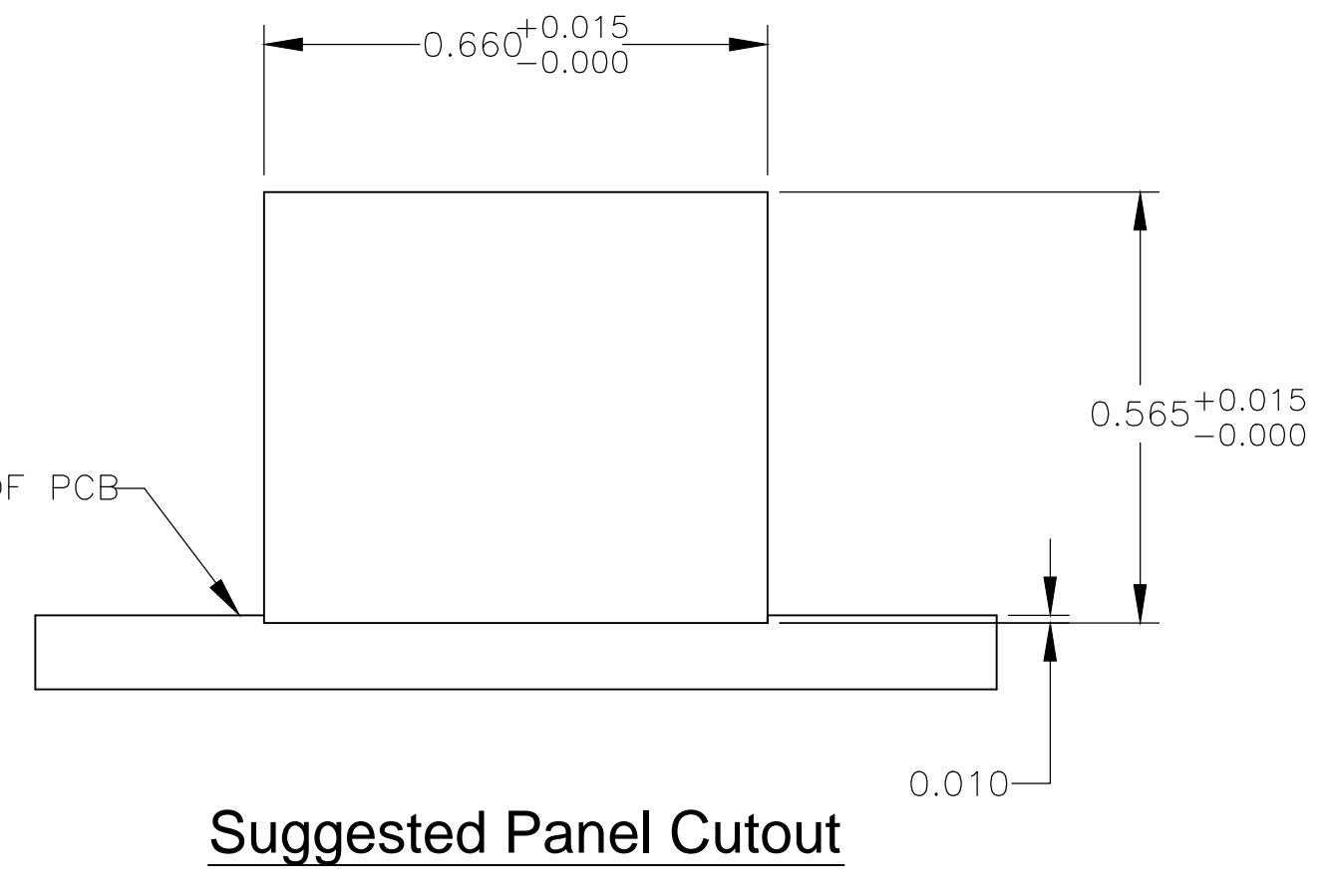

ELECTRICAL:
 4G02ET GIGABIT MAGNETIC CIRCUIT

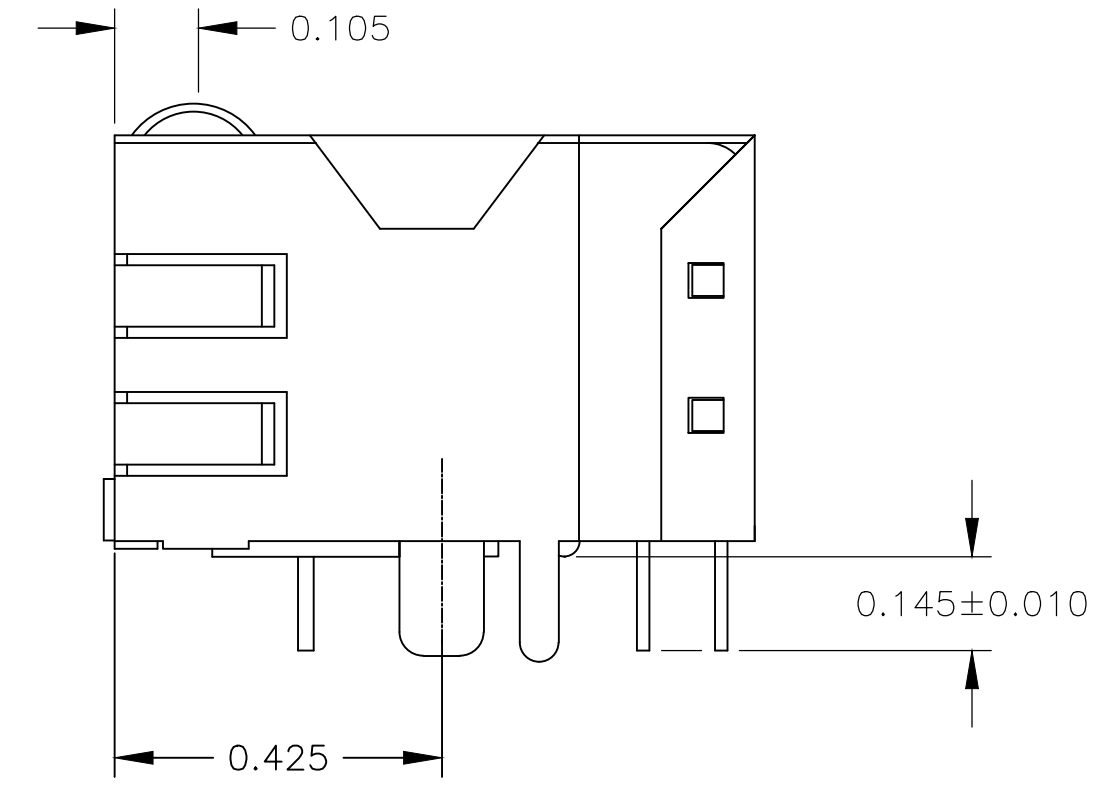
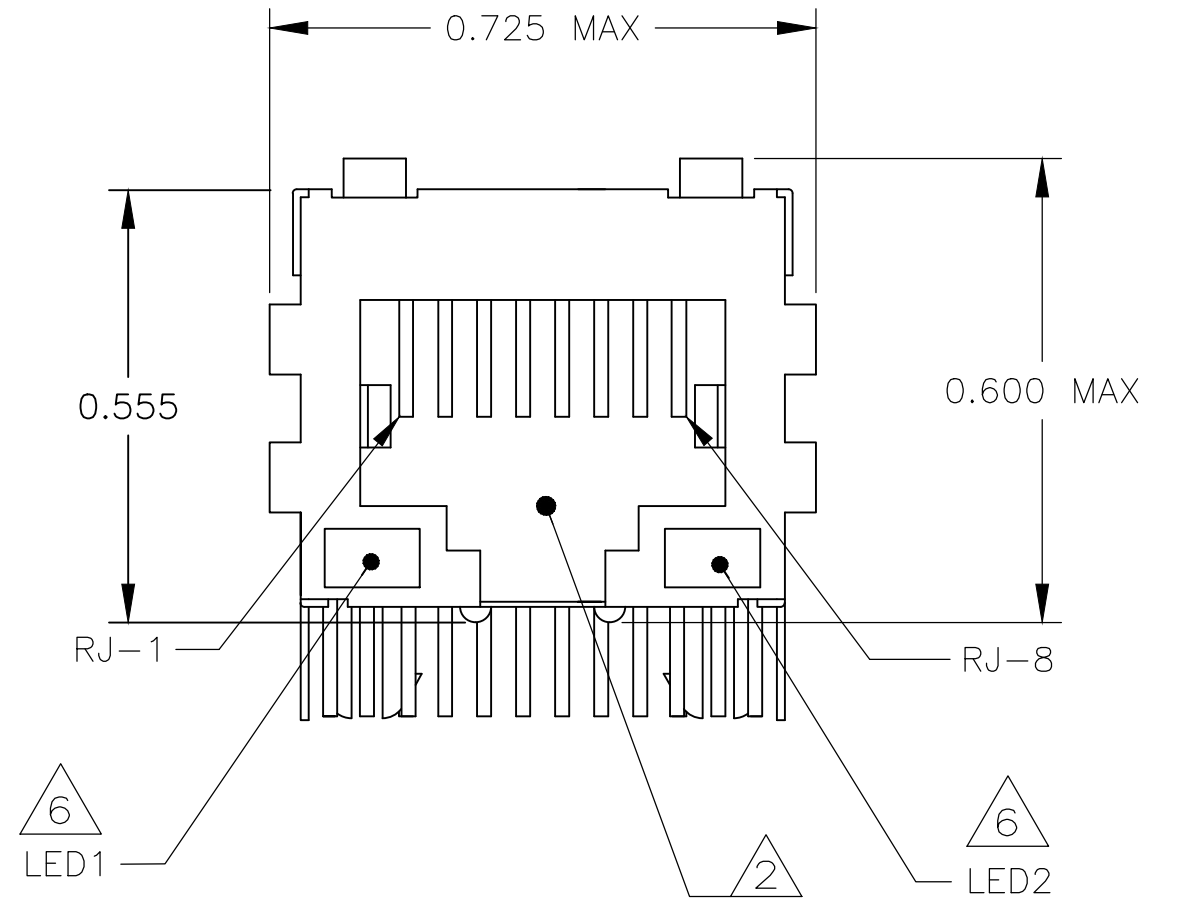
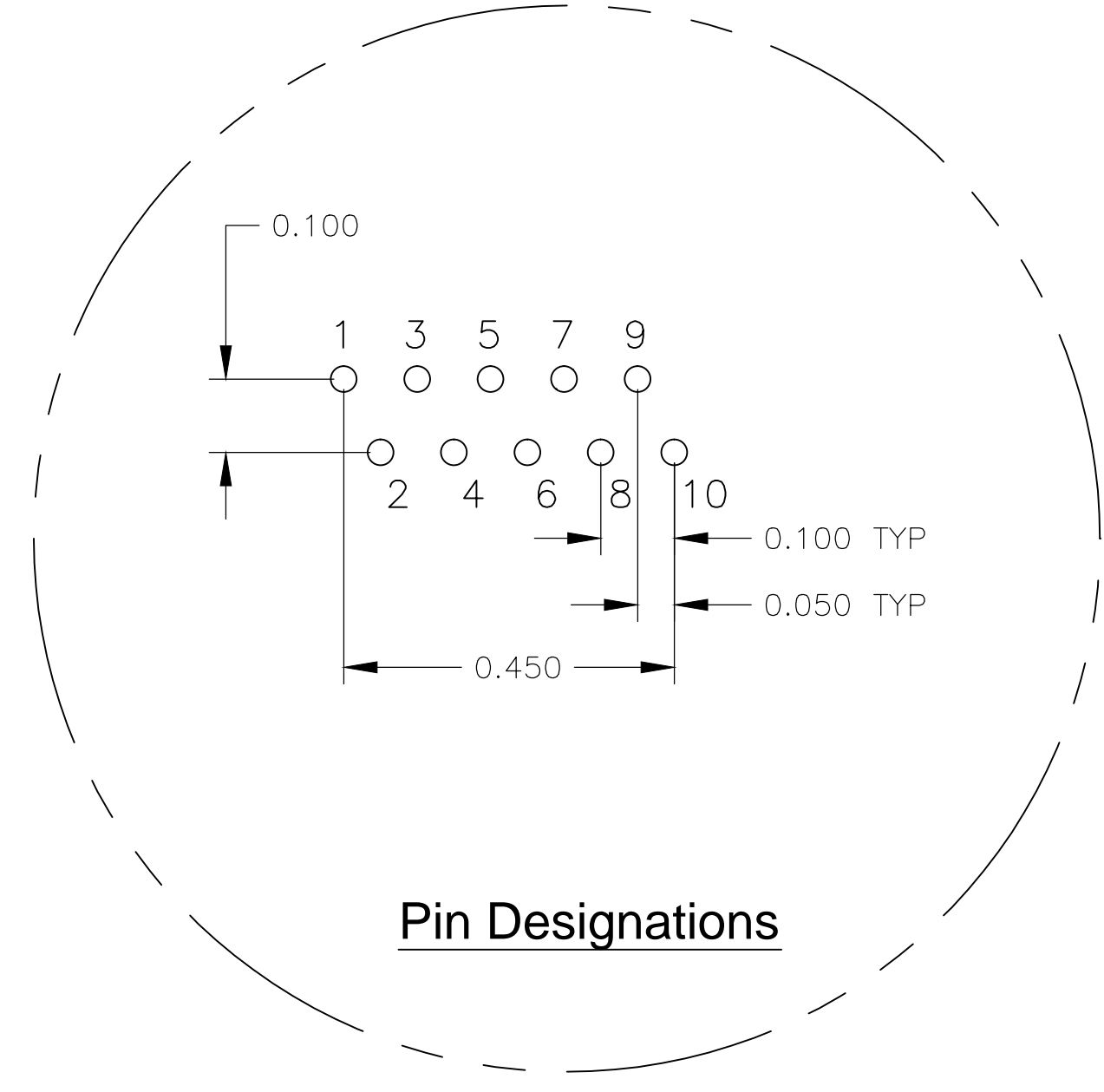
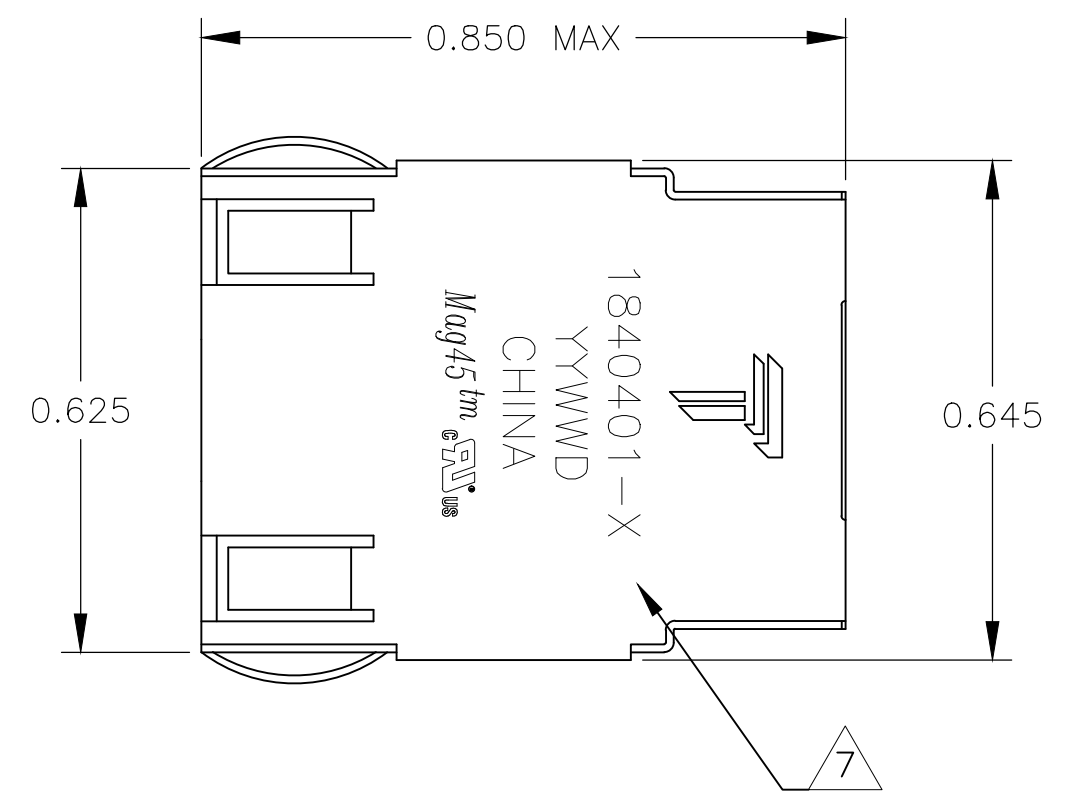
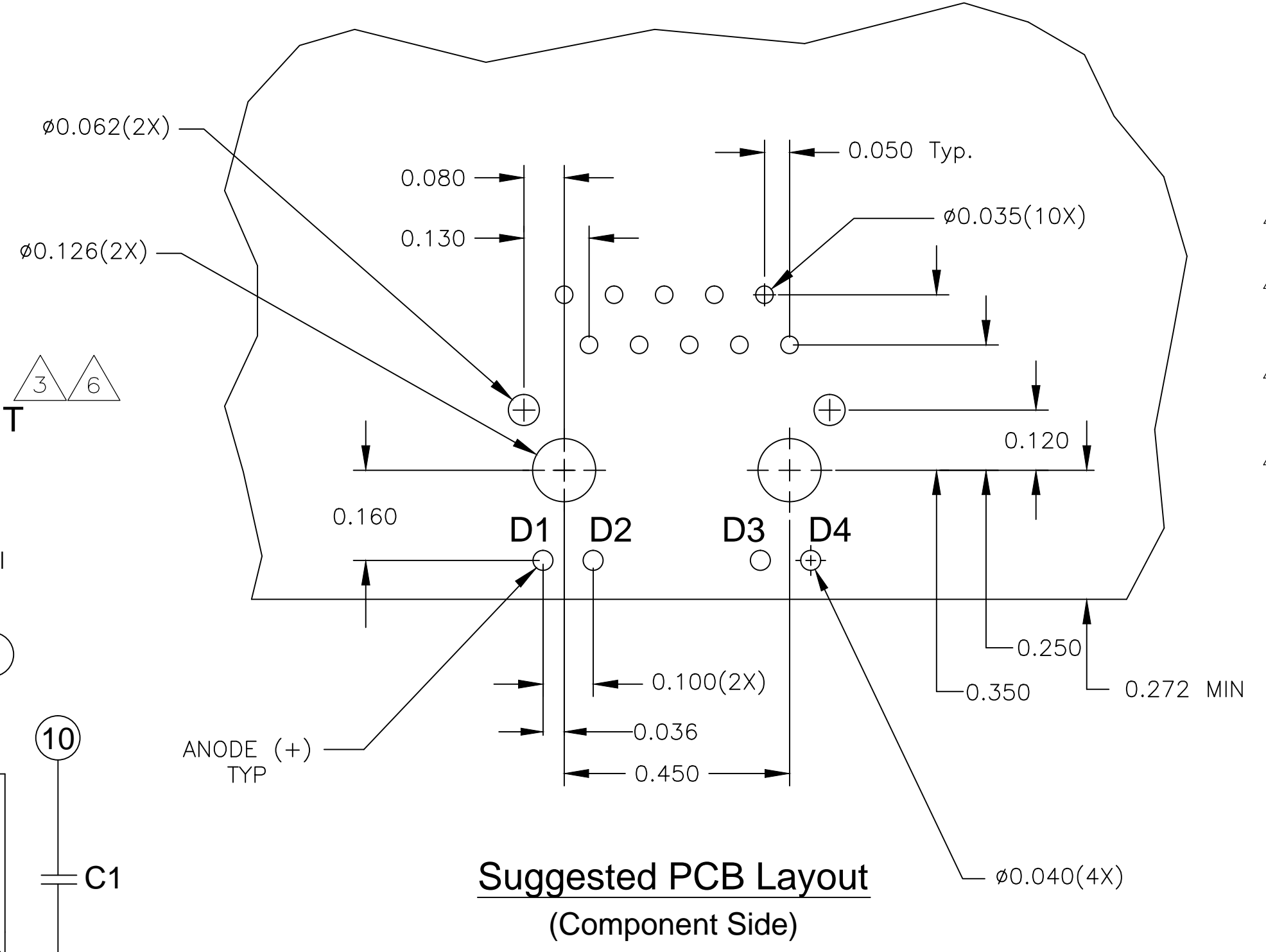
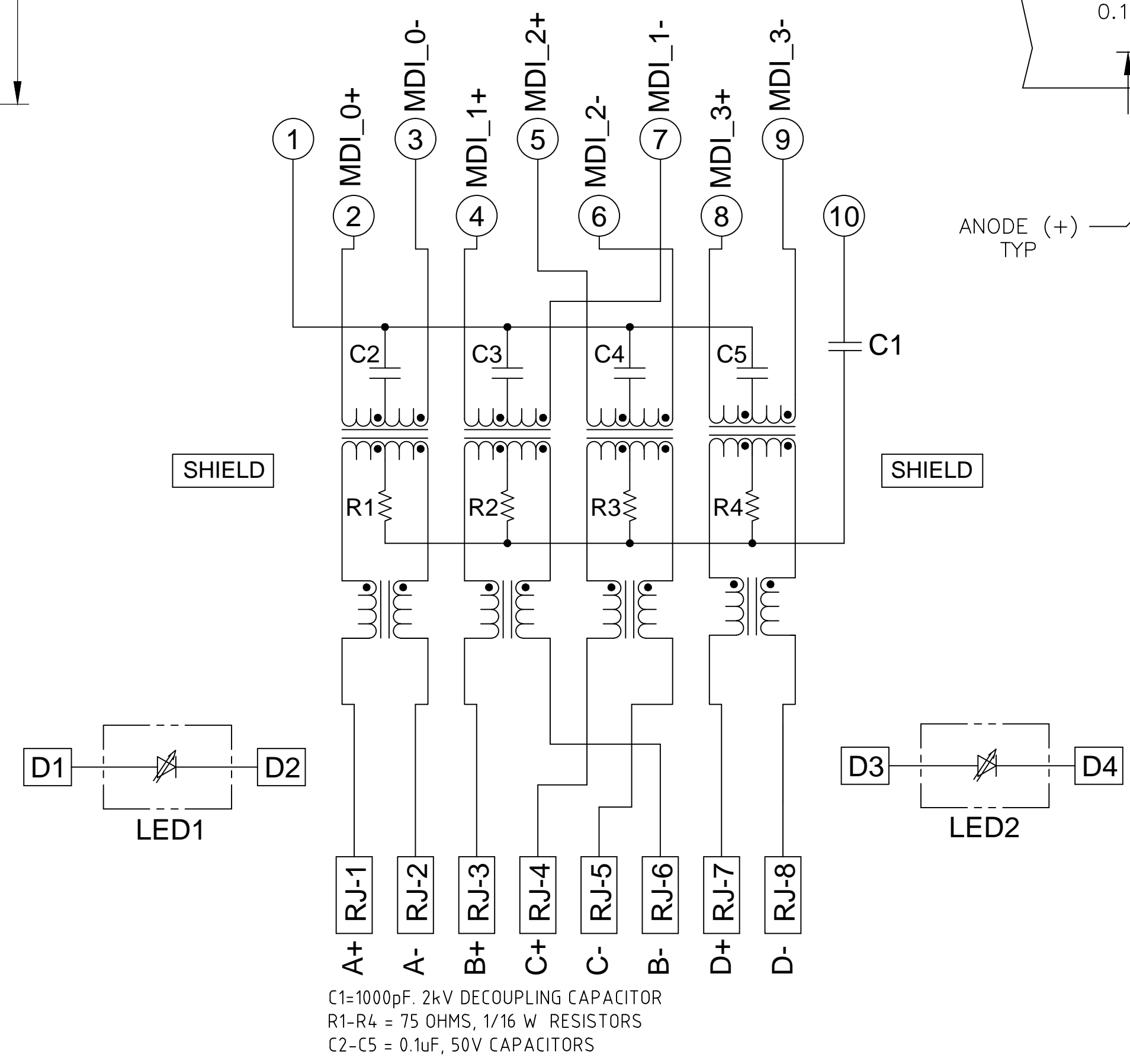

- ⚠️ **MATERIALS:**
 - HOUSING - THERMOPLASTIC PET POLYESTER FLAMMABILITY RATING UL 94V-0.
 - SHIELD - .010" THICK, C26800 BRASS PREPLATED WITH 30µINCH MIN SEMI-BRIGHT NICKEL. SOLDER TABS POST DIPPED WITH 100µINCH MIN SAC SOLDER.
 - MOD JACK CONTACTS - 0.0157 X 0.018" PHOSPHOR BRONZE, 50µINCH MIN OVERALL NICKEL UNDERPLATE WITH SELECT 50µINCH MIN HARD GOLD FINISH PLATE.
 - SOLDERTAILS WITH 100µINCH MIN MATTE TIN AND/OR SAC SOLDER DIP.
 - LIGHT EMITTING DIODE(LED) - DIFFUSED EPOXY LENS, 020" X .020" CARBON STEEL WIREFRAME LEADS PRE-PLATED WITH 80µINCH SILVER OVER 40µINCH NICKEL UNDERPLATE OVER 40µINCH COPPER UNDERPLATE. POST-PLATED WITH 100µIN MIN MATTE TIN AND/OR SAC SOLDER DIP OR PURE TIN SOLDER DIP.
- ⚠️ RJ45 JACK CAVITY CONFORMS TO FCC RULES AND REGULATIONS PART 68, SUB PART F.
- ⚠️ **MAGNETICS**
 - APPLICATION: 10/100/1000 BASE-T, EXTENDED TEMPERATURE
 - IMPEDANCE: 100 OHMS
 - TURNS RATIO (CHIP-CABLE): 1:1 ALL FOUR PAIRS
 - OPEN CIRCUIT INDUCTANCE (OCL): 350µH MIN @100kHz, 0.1VRMS, 8mADC BIAS FROM -40°C TO +85°C, ALL FOUR PAIRS
 - ALL FOUR PAIRS BI-DIRECTIONAL
 - PERFORMANCE @ 25°C:
 - INSERTION LOSS (IL): 1.1dB MAX FROM 0.5MHz TO 100MHz
 - RETURN LOSS (RL): 18dB MIN FROM 0.5MHz TO 40MHz
 - 12-20LOG(f/80)dB MIN FROM 40.1MHz TO 100MHz
 - CROSSTALK ATTENUATION: 35dB MIN FROM 0.5MHz TO 40MHz
 - 33-20LOG(f/50)dB MIN FROM 40.1MHz TO 100MHz
 - COMMON MODE REJECTION RATIO (CMRR): 30dB MIN FROM 0.5MHz TO 100MHz
 - ISOLATION VOLTAGE: COMPLIES WITH IEEE802.3 2002, PARA 40.6.1.1, ITEM b.
 - OPERATING TEMPERATURE: FROM -40°C TO +85°C.
- ⚠️ ALL DIMENSIONS NOMINAL UNLESS OTHERWISE NOTED.
- ⚠️ LEDs ARE DRIVEN WITH CONSTANT CURRENT AT APPROX 20mA.
 LED COLOR: DOMINANT WAVELENGTH (λD): GREEN 568 nm TYP @ IF=20mA
 FORWARD VOLTAGE (VF): GREEN 2.2V TYP @ IF=20mA
- ⚠️ INDICATED CONNECTIONS ARE FOR NIC CONFIGURATION. THE MAGNETICS ARE SYMMETRICAL, AND SUPPORTS AUTO-MDI/MDIX.
- ⚠️ TRP CONNECTOR LOGO, PART NUMBER, DATE CODE, COUNTRY OF ORIGIN AND AGENCY APPROVAL MARKING IN APPROXIMATE LOCATION SHOWN.
- 8 THE PART IS RECOMMENDED FOR WAVE SOLDERING PROCESS, PREHEAT TEMPRATURE IS 120°C TO 160°C, 120 SECONDS TO 180 SECONDS, PEAK SOLDERING TEMPERATURE IS 260 °C MAX, 10 SECONDS MAX.

THIS DRAWING IS A CONTROLLED DOCUMENT.		DWI D. FAROLE 17MAR2005	GREEN LED1	GREEN LED2	5-1840401-7 PART NUMBER
DIMENSIONS: INCHES		TOLERANCES UNLESS OTHERWISE SPECIFIED: 0 PLC ± - 1 PLC ± .010 2 PLC ± .010 3 PLC ± .005 4 PLC ± .005 ANGLES ± -	TRP connector Dongguan China		
MATERIAL		APVD S. FLICKINGER 18MAR2005	PRODUCT SPEC 108-2100 APPLICATION SPEC NAME 1X1 MAG45(TM), MODULAR JACK, 4G02ET SCHEMATIC, 4G02ET GIGABIT MAGNETIC CIRCUIT, SHIELDED, DECOUPLING CAPACITOR, WITH LEDS SIZE CAGE CODE DRAWING NO RESTRICTED TO WEIGHT A1 00779 ©=1840401 CUSTOMER DRAWING SCALE NTS SHEET 1 OF 1 REV C		