

REVISIONS					
#	LN	DESCRIPTION	DATE	EN	APPD
D		LOGO CHANGE	07APR2013	QL	KZ

MECHANICAL:

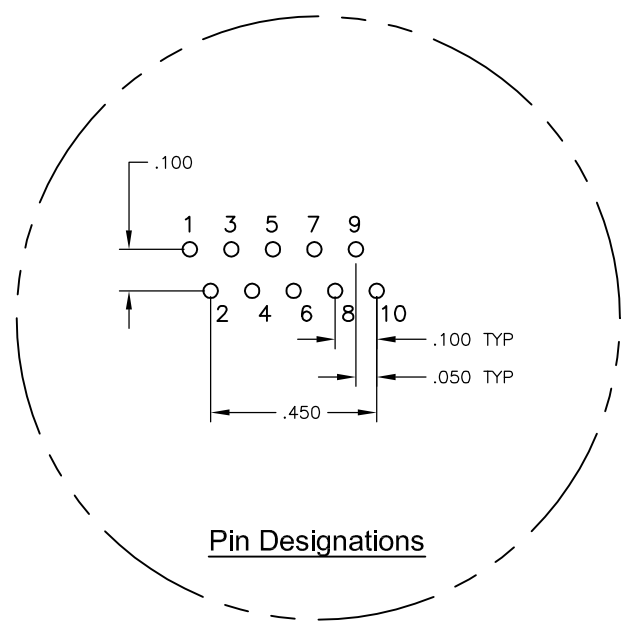
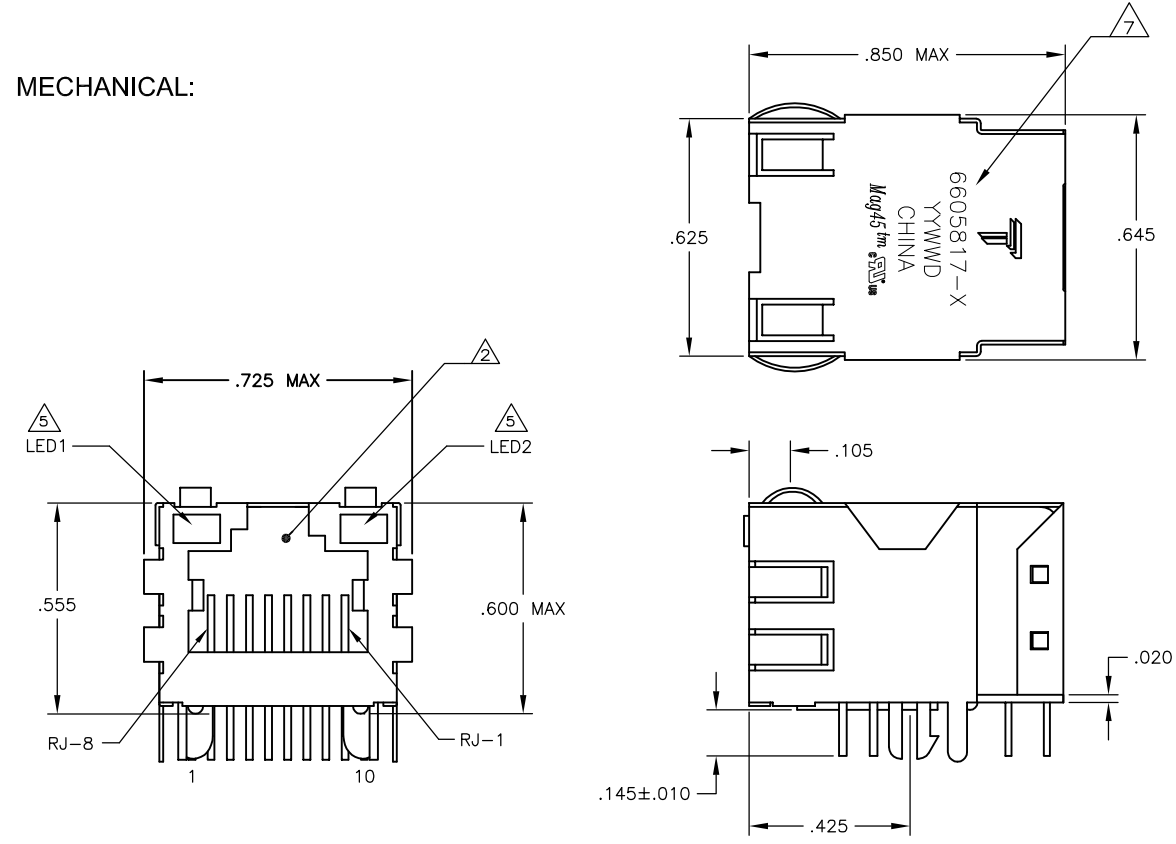

- △ MATERIALS:
 - HOUSING - THERMOPLASTIC PET POLYESTER FLAMMABILITY RATING UL 94V-0.
 - SHIELD - .010" THICK, C26800 BRASS PREPLATED WITH 30μINCH MIN SEMI-BRIGHT NICKEL, SOLDER TABS POST DIPPED WITH 100μINCH MIN SAC SOLDER.
 - MOD JACK CONTACTS - 0.0157" x 0.018" PHOSPHOR BRONZE, 50μINCH MIN OVERALL NICKEL UNDERPLATE, WITH SELECT 50μINCH MIN HARD GOLD FINISH PLATE. SOLDER TAILS WITH 100μINCH MIN MATTE TIN AND/OR SAC SOLDER DIP.
 - LIGHT EMITTING DIODE(LED) - DIFFUSED EPOXY LENS, .020" x .020" CARBON STEEL WIREFRAME LEADS PRE-PLATED WITH 80μINCH SILVER OVER 4.0μINCH NICKEL UNDERPLATE OVER 40μINCH COPPER UNDERPLATE, POST-PLATED WITH 100μINCH MIN MATTE TIN AND/OR SAC SOLDER DIP OR PURE TIN SOLDER DIP.

△ RJ45 JACK CAVITY CONFORMS TO FCC RULES AND REGULATIONS PART 68, SUB PART F.

- △ MAGNETICS
 - IMPEDANCE: 100 OHMS
 - TURNS RATIO (CHIP:CABLE): TX = 1:1, RX = 1:1
 - OPEN CIRCUIT INDUCTANCE (OCL): 350uH MIN @100kHz, 0.1VRMS, 8mADC BIAS FROM 0°C TO 70°C, TX AND RX
 - POE CURRENT: 350mADC MAX
 - PERFORMANCE @ 25°C:
 - INSERTION LOSS (IL): 1.1dB MAX FROM 0.5MHz TO 100MHz
 - RETURN LOSS (RL): 18dB MIN FROM 0.5MHz TO 30MHz
 - 18-20LOG(f/30)dB MIN FROM 30.1MHz TO 60MHz
 - 12dB MIN FROM 60.1MHz TO 80MHz
 - CROSSTALK ATTENUATION: 35dB MIN FROM 0.5MHz TO 40MHz
 - 33-20xLOG(f/50)dB MIN FROM 40.1MHz TO 100MHz
 - COMMON MODE REJECTION RATIO (CMRR): 30dB MIN FROM 0.5MHz TO 100MHz
 - ISOLATION VOLTAGE:1500VAC (MAX) AT 60Hz FOR 60 SECS.

4. OPERATING TEMPERATURE: FROM 0°C TO +70°C.

- △ LED WITH 250 OHM RESISTORS, LED IS DRIVEN WITH 5V VOLTAGE AND THE MAX OPERATING CURRENT IS 20mA.
 - LED COLOR : DOMINANT WAVELENGTH (AD): GREEN 568 nm TYP. @ VF=5V
 - FORWARD CURRENT (IF): GREEN 12 mA TYP. @ VF=5V
 - DOMINANT WAVELENGTH (AD): YELLOW 588 nm TYP. @ VF=5V
 - FORWARD CURRENT (IF): YELLOW 13 mA TYP. @ VF=5V

△ INDICATED CONNECTIONS ARE FOR NIC CONFIGURATION. THE MAGNETICS ARE ASYMMETRIC, AND DO NOT SUPPORT AUTO-MDI/MDIX.

△ TRP CONNECTOR LOGO, PART NUMBER, DATE CODE, COUNTRY OF ORIGIN AND AGENCY APPROVAL MARKING IN APPROXIMATE LOCATION SHOWN.

8. THESE PARTS ARE RECOMMENDED FOR WAVE SOLDERING PROCESS, PREHEAT TEMPERATURE IS 120°C TO 160°C, 120 SECONDS TO 180 SECONDS, PEAK WAVE SOLDERING TEMPERATURE IS 260°C MAX, 10 SECONDS MAX.

7U14C SERIES MAGNETIC CIRCUIT

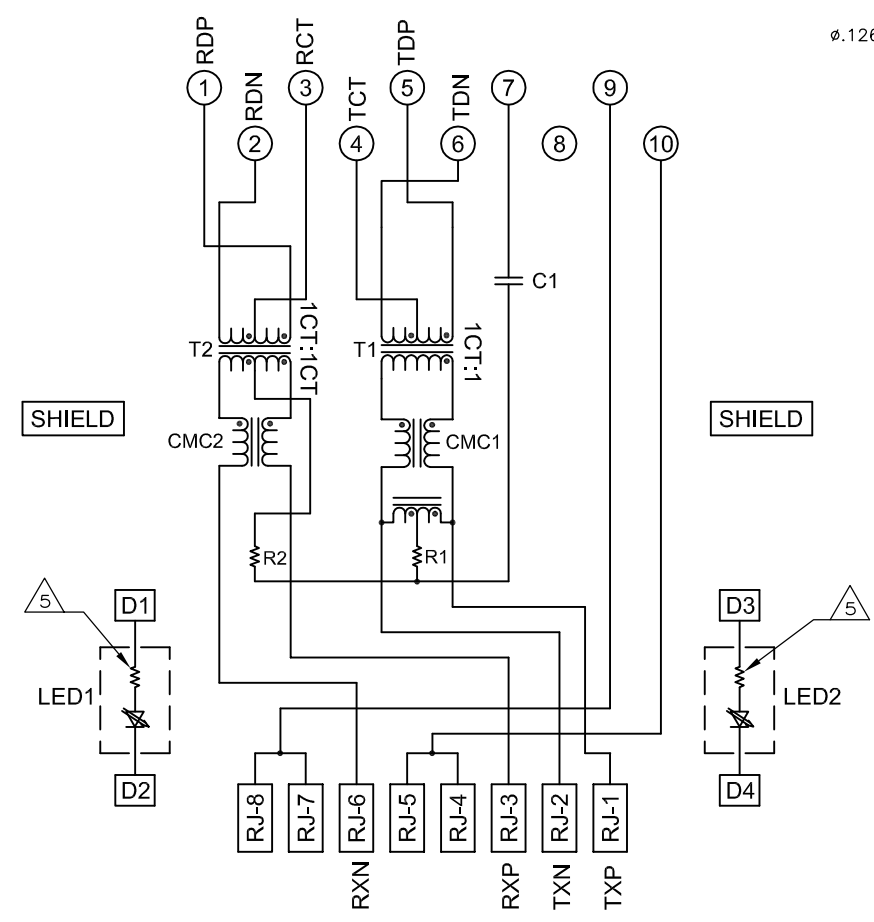

C1=1000pF, 2kV DECOUPLING CAPACITOR
R1-R4 = 75 OHMS, 1/16 W RESISTORS

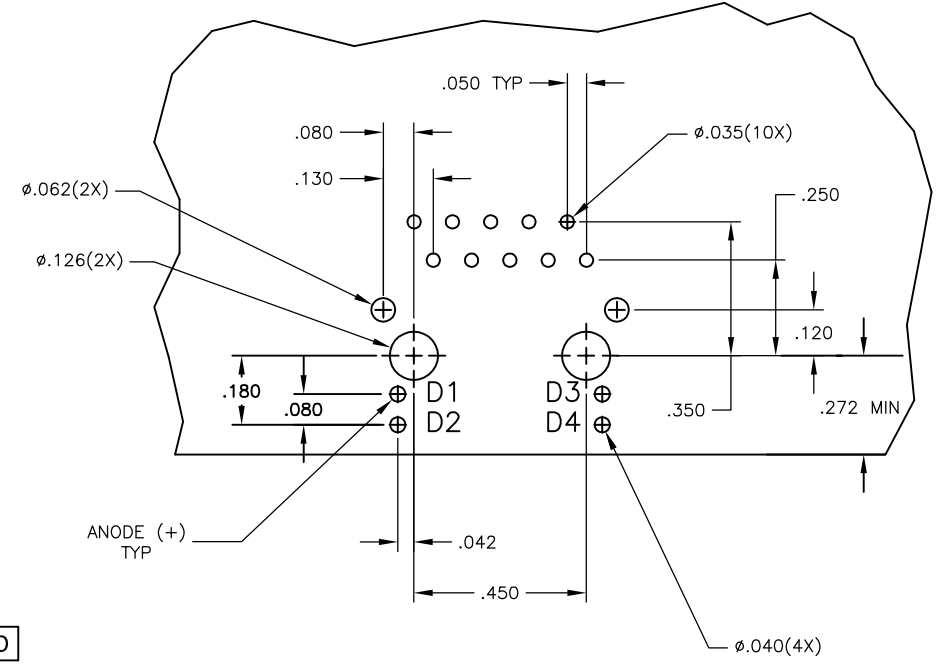

Suggested PCB Layout (Component Side)

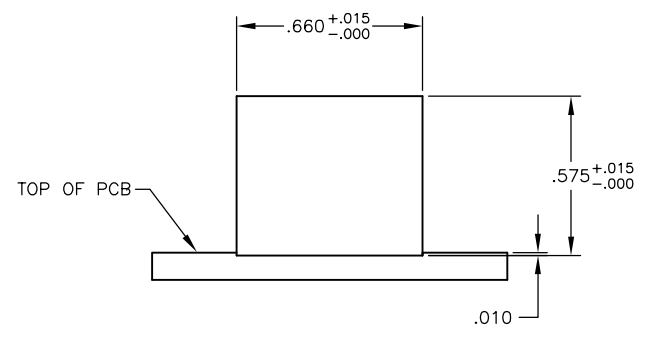

Suggested Panel Cutout

THIS DRAWING IS A CONTROLLED DOCUMENT.		ENR L VARELA - DOCKS	TRP connector
DIMENSIONS: INCHES		CHK D. FAROLE	Dongguan China
TOLERANCES UNLESS OTHERWISE SPECIFIED:		APPD D. FAROLE	
0 P/LC	± .005	PRODUCT SPEC	MMX1 MAG45(TM), MODULAR JACK, SHIELDED, 7UN2 SCHEMATIC, 7U14C UNUSED PAIR MAGNETIC CIRCUIT, DECOUPLING CAPACITOR, WITH RESISTOR LEADS
1 P/LC	± .010	APPLICATION SPEC	108-2100
2 P/LC	± .015	SIZE	A1
3 P/LC	± .020	SCALE	1:1
4 P/LC	± .025	DATE CODE	070709
ANGLES	± .005	DRAWING NO	6605817
MATERIAL	△	RESTRICTED TO	
FINISH	△	CUSTOMER DRAWING	
		SCALE	NTS
		SHEET	1 of 1
		REV	D

YELLOW	GREEN	5-6605817-2
LED1	LED2	PART NUMBER