

REVISIONS				
P	LTR	DESCRIPTION	DATE	APVD
D		LOGO CHANGE	10APR2013	RL KZ

1. MATERIALS:  
 HOUSING: BLACK, THERMOPLASTIC, RATED UL 94V-0  
 SHIELD: COPPER ALLOY, WITH NICKEL PLATE  
 SHELL: CARBON STEEL,  
 CONTACTS: PHOSPHER BRONZE  
 INSERTS: THREADED, STAINLESS STEEL  
 CONTACT PLATING: 0.05µm MIN GOLD OVER 0.76µm MIN PALLADIUM-NICKEL,  
 AT MATING INTERFACE CONTACT AREA
2. MAGNETICS  
 -APPLICATION: 10/100/1000 BASE-T  
 -IMPEDANCE: 100 OHMS  
 -TURNS RATIO (CHIP:CABLE): 1:1 ALL FOUR PAIRS  
 -OPEN CIRCUIT INDUCTANCE (OCL): 350µH MIN @100kHz, 0.1VRMS,  
 8mADC BIAS FROM 0°C TO 70°C, ALL FOUR PAIRS  
 -ALL FOUR PAIRS BI-DIRECTIONAL  
 -PERFORMANCE @ 25°C:  
 INSERTION LOSS (IL): 1.1dB MAX FROM 0.5MHz TO 100MHz  
 RETURN LOSS (RL): 18dB MIN FROM 0.5MHz TO 40MHz  
 12-20LOG(f/80)dB MIN FROM 40.1MHz TO 100MHz  
 CROSSTALK ATTENUATION: 35dB MIN FROM 0.5MHz TO 40MHz  
 33-20LOG(f/50)dB MIN FROM 40.1MHz TO 100MHz  
 COMMON MODE REJECTION RATIO (CMRR): 30dB MIN FROM 0.5MHz TO 100MHz  
 -ISOLATION VOLTAGE: COMPLIES WITH IEEE802.3 2002, PARA 40.6.1.1, ITEM b.

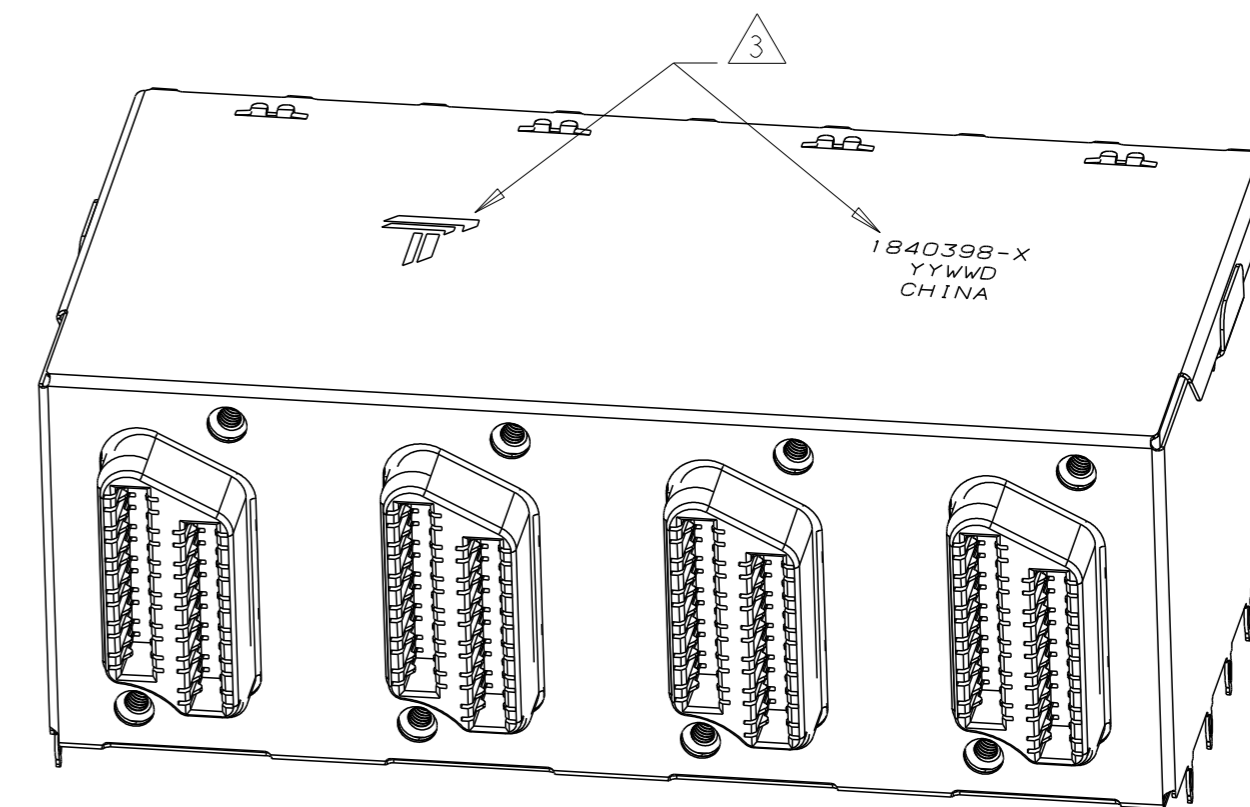

1840398-1  
SCALE 2:1

△ TRP CONNECTOR LOGO, PART NUMBER, DATE CODE AND COUNTRY OF ORIGIN, SHOWN IN APPROXIMATE LOCATION. DATE CODE: YYWW "YY" IS YEAR, "WW" IS WORK WEEK, "D" IS DAY OF WEEK, WITH SUNDAY=1

4. RECOMMENDED PCB THICKNESS 1.5mm (.062")
5. SCREW LOCKS ARE FOR USE WITH JACKSCREWS TO PROVIDE CABLE RETENTION
6. RECOMMENDED TORQUE FOR SCREW LOCK IS 4 IN-LB

△ SCREW LOCK DESIGNATION:  
 SCREW LOCKS MUST BE ORDERED SEPARATELY FROM TABLE BELOW,  
 SCREW LOCKS PACKAGED IN QUANTITIES OF 960 PIECES

>1mm-<2mm	1339381-2
>0mm-<1mm	1339381-1
PANEL THICKNESS	SCREW LOCK PART NUMBER

8. OPERATING TEMPERATURE: FROM 0°C TO 70°C

1840398-1  
PART NUMBER

THIS DRAWING IS A CONTROLLED DOCUMENT.		DWN TOMMY REN 09MAY2006	TRP connector Dongguan China															
DIMENSIONS: mm		CHK KEITH ZHU 09MAY2006																
TOLERANCES UNLESS OTHERWISE SPECIFIED:		APVD TEDDY XIONG 09MAY2006	NAME 4 POSITION MODULE, NON-OFFSET, NON-POE, MRJ-21, 9G33 CIRCUIT															
<table border="0"> <tr> <td>0 PLC</td> <td>±0.25</td> </tr> <tr> <td>1 PLC</td> <td>±0.25</td> </tr> <tr> <td>2 PLC</td> <td>±0.25</td> </tr> <tr> <td>3 PLC</td> <td>±0.25</td> </tr> <tr> <td>4 PLC</td> <td>±</td> </tr> <tr> <td>ANGLES</td> <td>±</td> </tr> <tr> <td>FINISH</td> <td>±</td> </tr> </table>		0 PLC	±0.25	1 PLC	±0.25	2 PLC	±0.25	3 PLC	±0.25	4 PLC	±	ANGLES	±	FINISH	±	PRODUCT SPEC 108-2186	SIZE A2	DRAWING NO C=1840398
0 PLC	±0.25																	
1 PLC	±0.25																	
2 PLC	±0.25																	
3 PLC	±0.25																	
4 PLC	±																	
ANGLES	±																	
FINISH	±																	
MATERIAL SEE NOTES		WEIGHT -	CAGE CODE	RESTRICTED TO														
		CUSTOMER DRAWING		SCALE NTS														
		SHEET 1 OF 6		REV D														

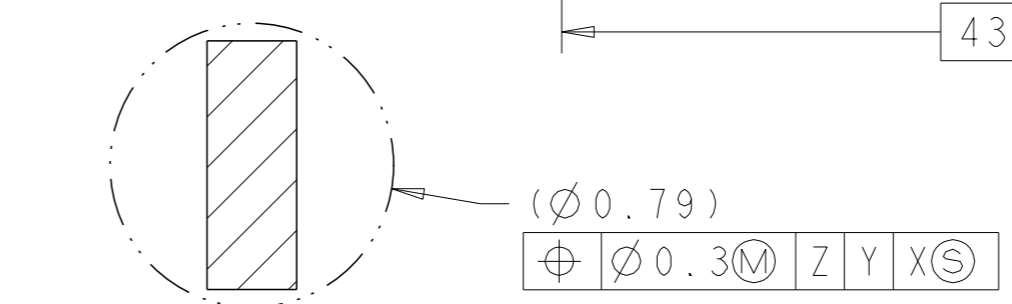
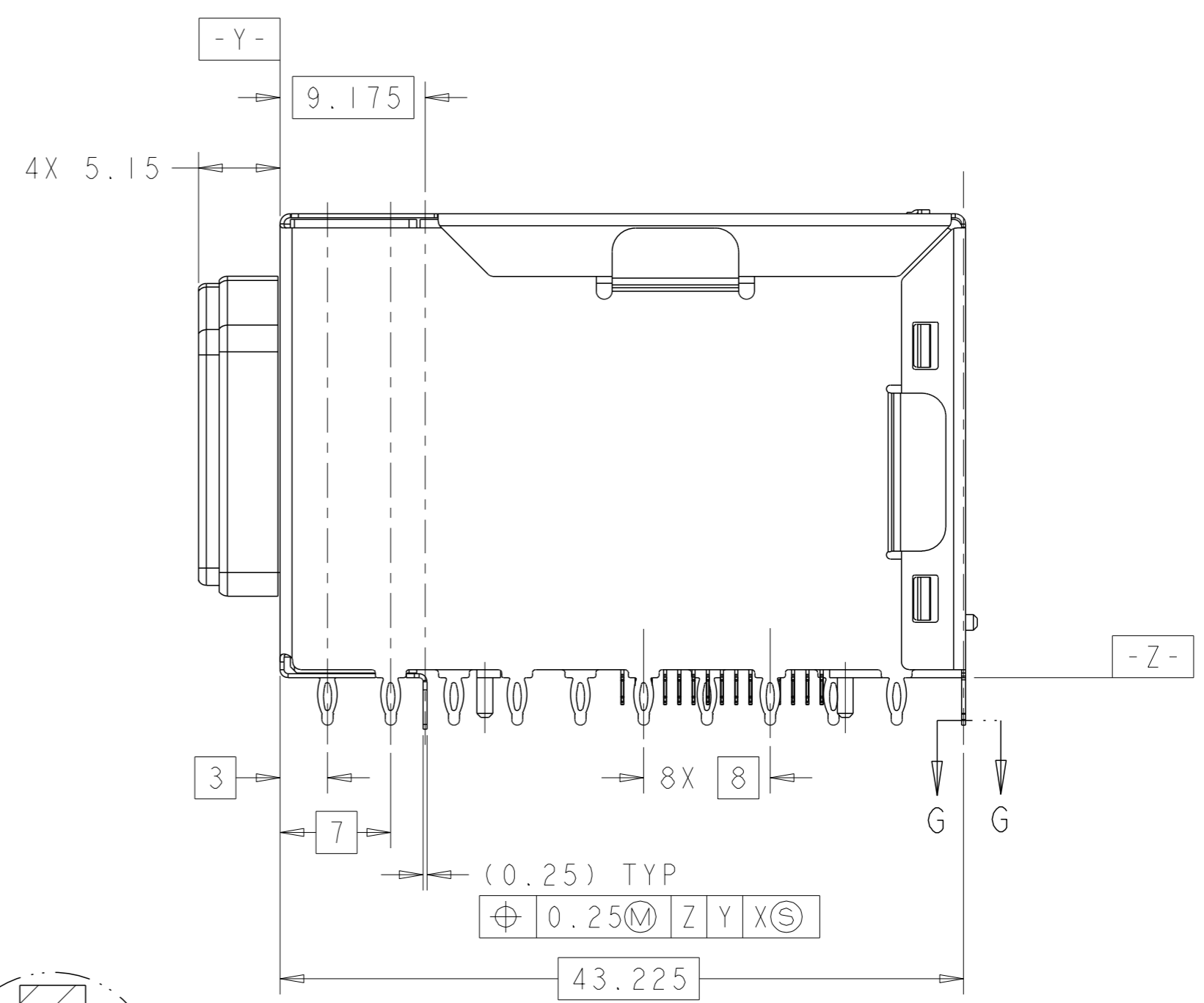
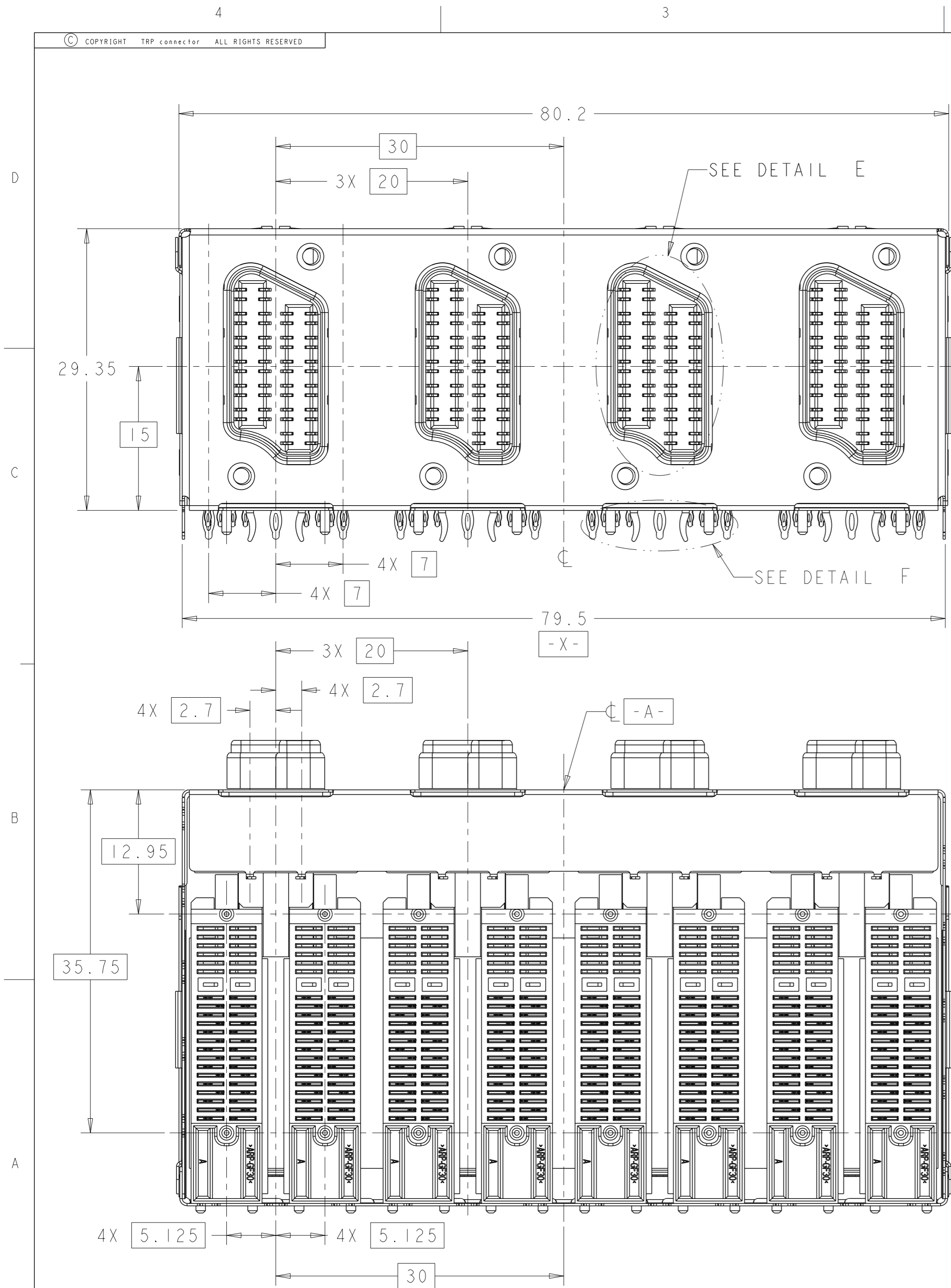

SECTION G-G  
 22X INDIVIDUALLY  
 SCALE 50:1

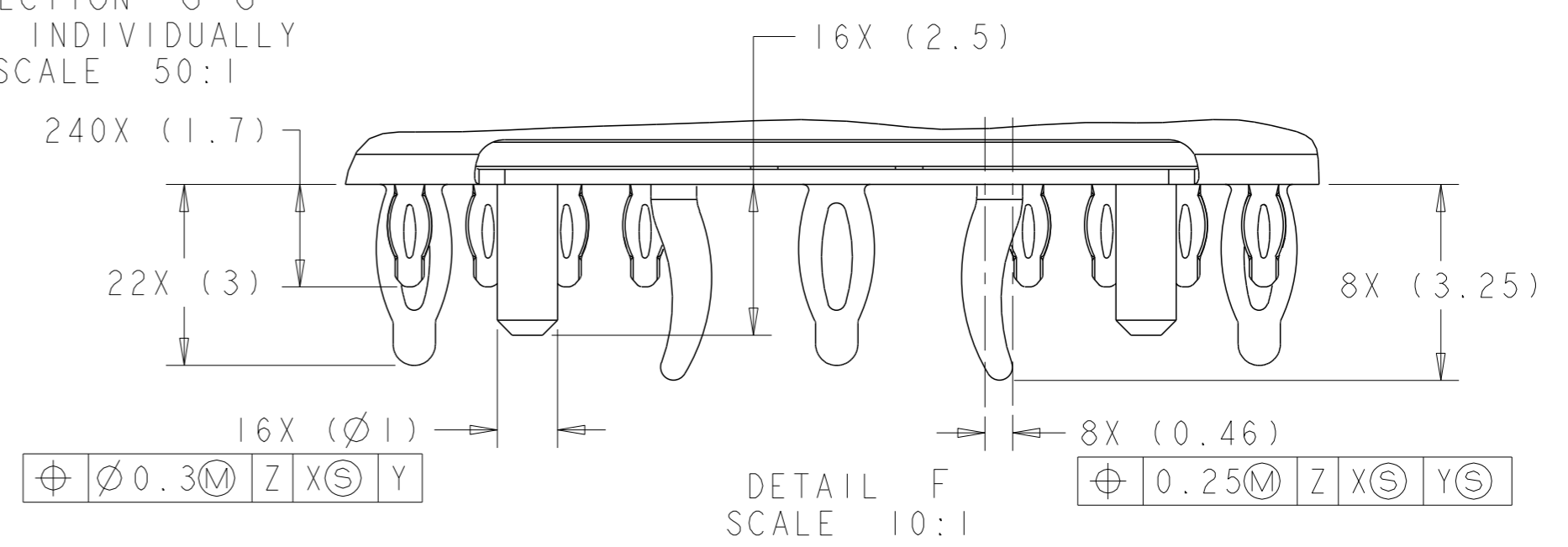

DETAIL F  
 SCALE 10:1

THIS DRAWING IS A CONTROLLED DOCUMENT.		DWN TOMMY REN 09MAY2006	<p>TRP connector Dongguan China</p>													
DIMENSIONS: mm		CHK KEITH ZHU 09MAY2006														
TOLERANCES UNLESS OTHERWISE SPECIFIED:		APVD TEDDY XIONG 09MAY2006														
<table border="1"> <tr> <td>0 PLC</td> <td>±0.25</td> </tr> <tr> <td>1 PLC</td> <td>±0.25</td> </tr> <tr> <td>2 PLC</td> <td>±0.25</td> </tr> <tr> <td>3 PLC</td> <td>±0.25</td> </tr> <tr> <td>4 PLC</td> <td>±0.25</td> </tr> <tr> <td>ANGLES</td> <td>±</td> </tr> <tr> <td>FINISH</td> <td>±</td> </tr> </table>		0 PLC		±0.25	1 PLC	±0.25	2 PLC	±0.25	3 PLC	±0.25	4 PLC	±0.25	ANGLES	±	FINISH	±
0 PLC	±0.25															
1 PLC	±0.25															
2 PLC	±0.25															
3 PLC	±0.25															
4 PLC	±0.25															
ANGLES	±															
FINISH	±															
MATERIAL SEE NOTES		NAME 4 POSITION MODULE, NON-OFFSET, NON-POE, MRJ-21, 9G33 CIRCUIT SIZE A2 CAGE CODE C=1840398 SCALE NTS	DRAWING NO - SHEET 2 OF 6 REV D													

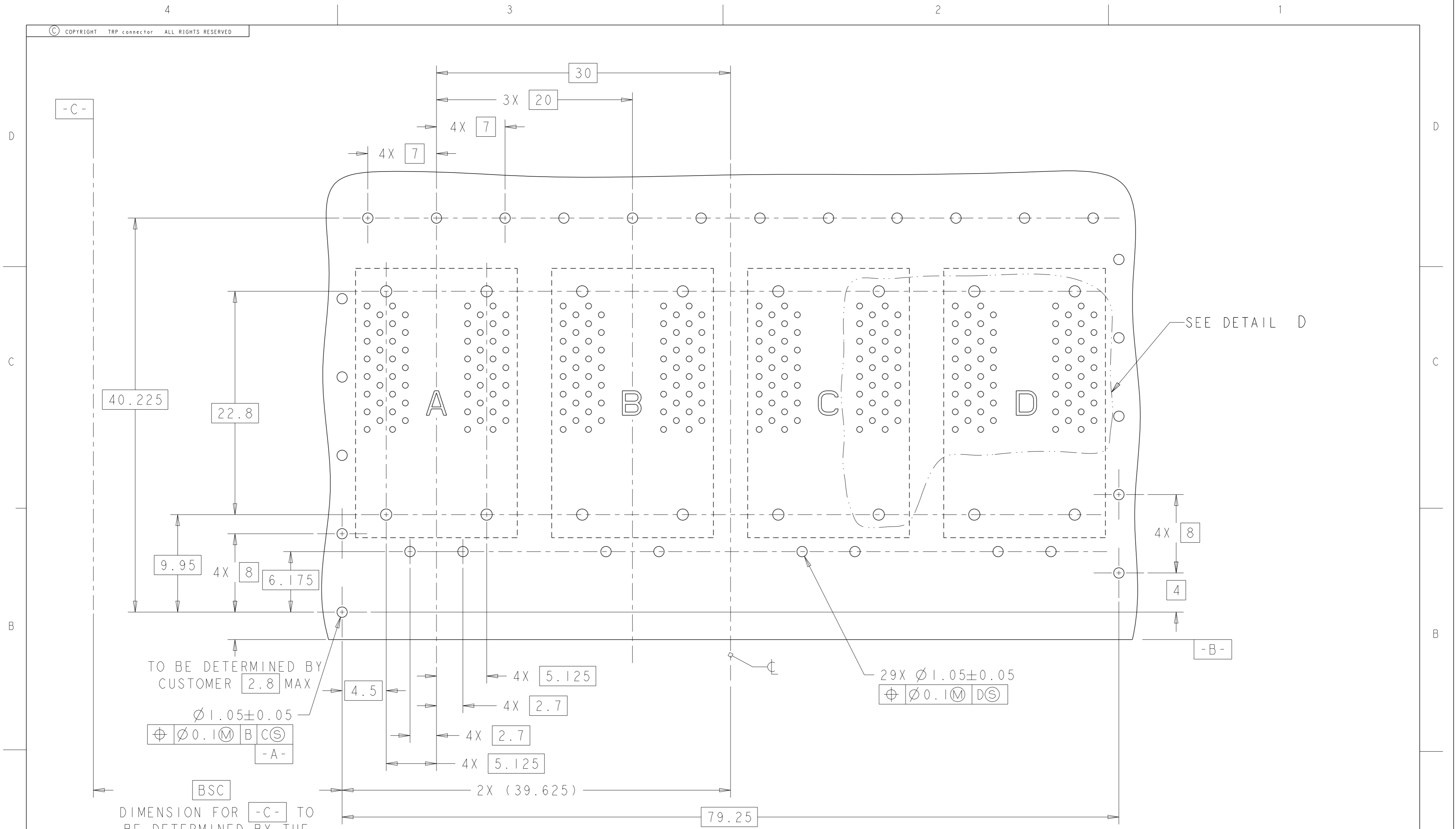

TO BE DETERMINED BY CUSTOMER 2.8 MAX

Ø 1.05±0.05  
 ⊕ Ø 0.1(M) B C(S)  
 -A-

BSC  
 DIMENSION FOR -C- TO BE DETERMINED BY THE CUSTOMER

29X Ø1.05±0.05  
 ⊕ Ø 0.1(M) D(S)

RECOMMENDED PCB LAYOUT  
 SCALE 4:1

THIS DRAWING IS A CONTROLLED DOCUMENT.		DWN TOMMY REN 09MAY2006	<p>TRP connector Dongguan China</p>													
DIMENSIONS: mm		CHK KEITH ZHU 09MAY2006														
TOLERANCES UNLESS OTHERWISE SPECIFIED:		APVD TEDDY XIONG 09MAY2006														
<table border="1"> <tr><td>0 PLC</td><td>±0.25</td></tr> <tr><td>1 PLC</td><td>±0.25</td></tr> <tr><td>2 PLC</td><td>±0.25</td></tr> <tr><td>3 PLC</td><td>±0.25</td></tr> <tr><td>4 PLC</td><td>±0.25</td></tr> <tr><td>ANGLES</td><td>±</td></tr> <tr><td>FINISH</td><td>±</td></tr> </table>		0 PLC		±0.25	1 PLC	±0.25	2 PLC	±0.25	3 PLC	±0.25	4 PLC	±0.25	ANGLES	±	FINISH	±
0 PLC	±0.25															
1 PLC	±0.25															
2 PLC	±0.25															
3 PLC	±0.25															
4 PLC	±0.25															
ANGLES	±															
FINISH	±															
MATERIAL SEE NOTES		NAME 4 POSITION MODULE, NON-OFFSET, NON-POE, MRJ-21, 9G33 CIRCUIT SIZE A2 CAGE CODE C=1840398 DRAWING NO - RESTRICTED TO - SHEET 3 OF 6 REV D														
CUSTOMER DRAWING																

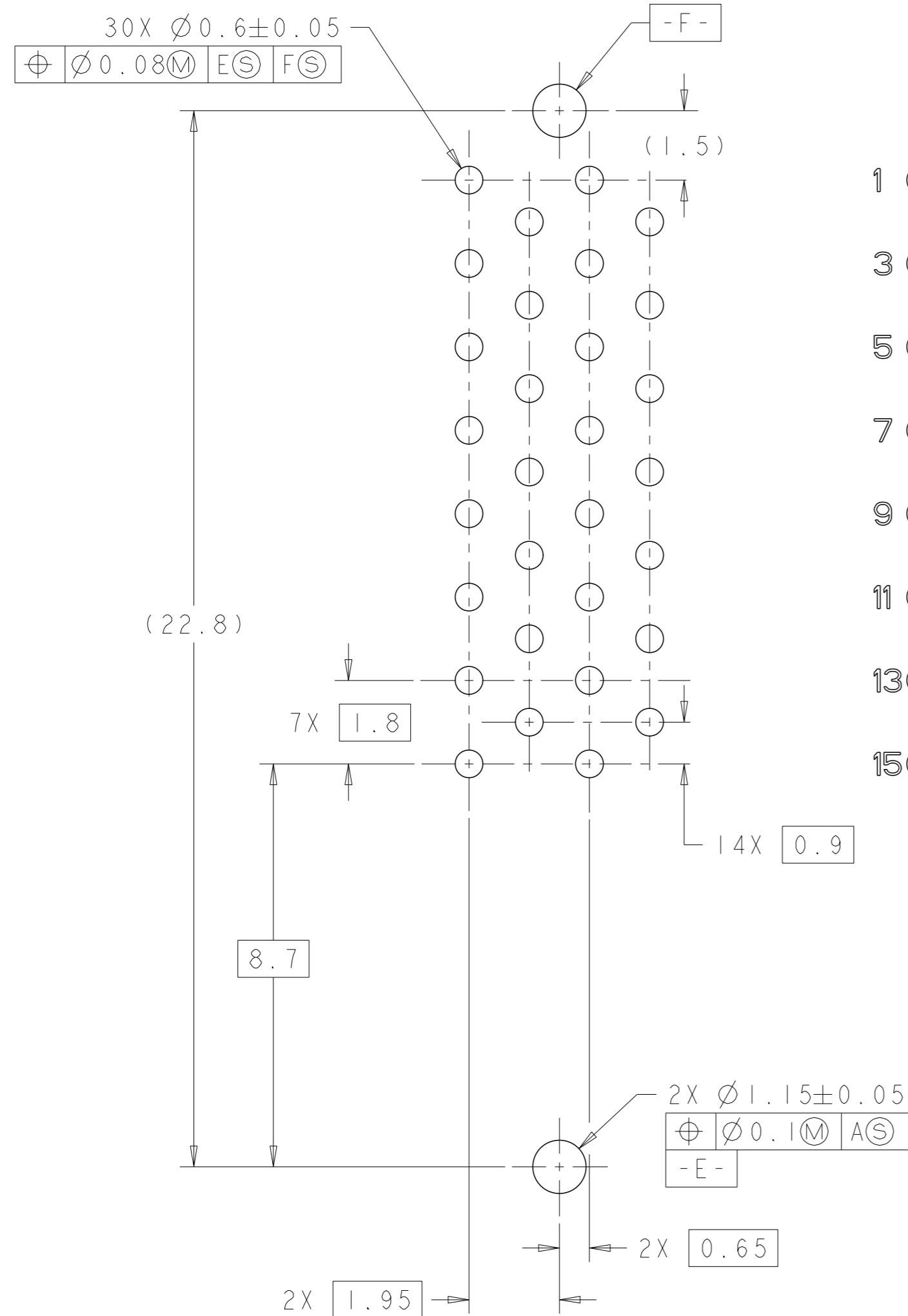

- (10.25)
- |      |     |      |     |
|------|-----|------|-----|
| 1 ○  | ○16 | 31 ○ | ○46 |
| 2 ○  | ○17 | 32 ○ | ○47 |
| 3 ○  | ○18 | 33 ○ | ○48 |
| 4 ○  | ○19 | 34 ○ | ○49 |
| 5 ○  | ○20 | 35 ○ | ○50 |
| 6 ○  | ○21 | 36 ○ | ○51 |
| 7 ○  | ○22 | 37 ○ | ○52 |
| 8 ○  | ○23 | 38 ○ | ○53 |
| 9 ○  | ○24 | 39 ○ | ○54 |
| 10 ○ | ○25 | 40 ○ | ○55 |
| 11 ○ | ○26 | 41 ○ | ○56 |
| 12 ○ | ○27 | 42 ○ | ○57 |
| 13 ○ | ○28 | 43 ○ | ○58 |
| 14 ○ | ○29 | 44 ○ | ○59 |
| 15 ○ | ○30 | 45 ○ | ○60 |

HOST BOARD PIN IDENTIFIERS

DETAIL D  
TYPICAL  
SCALE 10:1

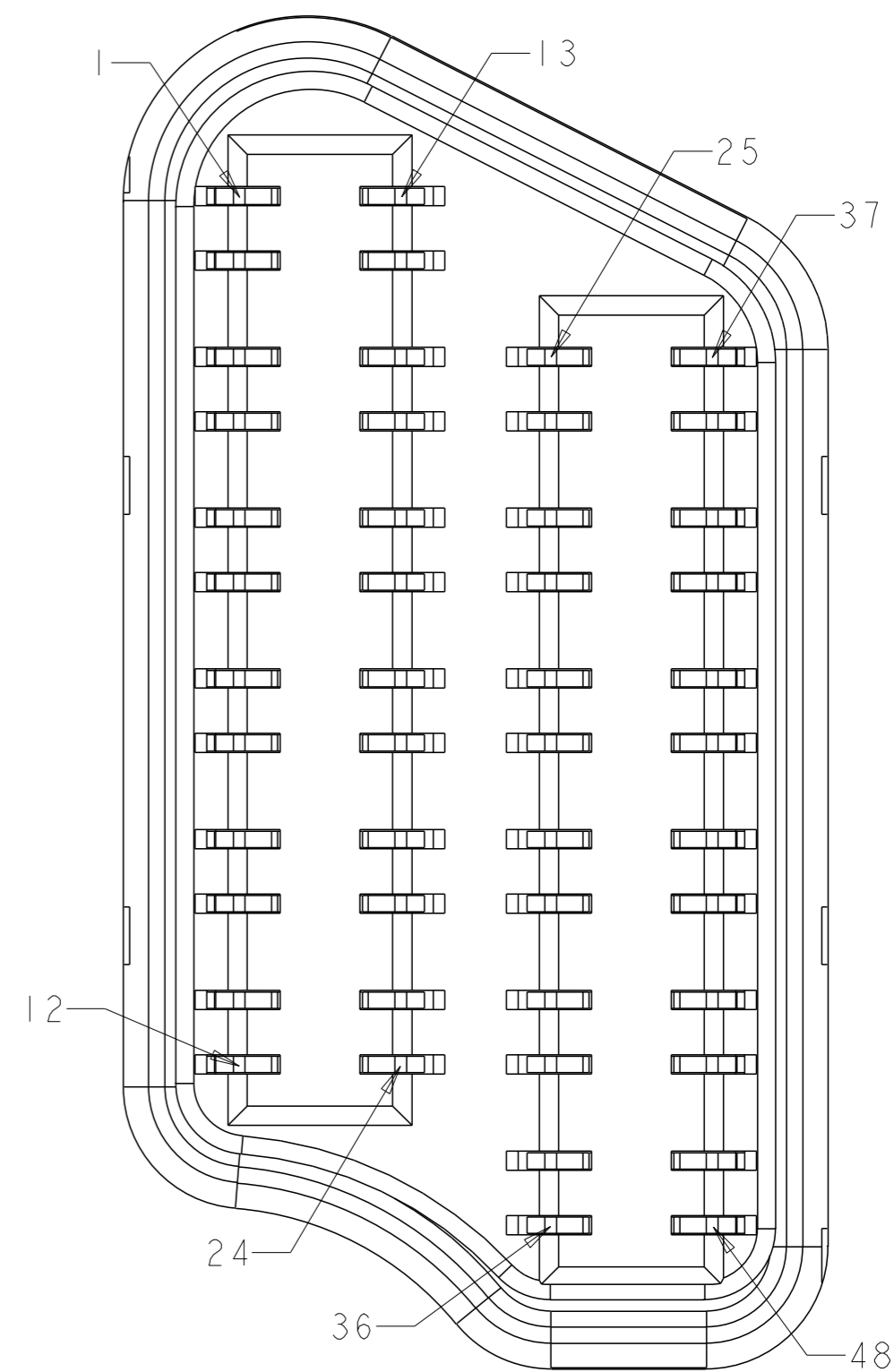

DETAIL E  
MRJ INTERFACE PIN DESIGNATIONS  
4X INDIVIDUALLY  
SCALE 10:1

THIS DRAWING IS A CONTROLLED DOCUMENT.		DWN TOMMY REN 09MAY2006	 TRP connector Dongguan China															
DIMENSIONS: mm		CHK KEITH ZHU 09MAY2006																
TOLERANCES UNLESS OTHERWISE SPECIFIED:		APVD TEDDY XIONG 09MAY2006	NAME 4 POSITION MODULE, NON-OFFSET, NON-POE, MRJ-21, 9G33 CIRCUIT															
<table border="0"> <tr> <td>0 PLC</td> <td>±0.25</td> </tr> <tr> <td>1 PLC</td> <td>±0.25</td> </tr> <tr> <td>2 PLC</td> <td>±0.25</td> </tr> <tr> <td>3 PLC</td> <td>±0.25</td> </tr> <tr> <td>4 PLC</td> <td>±0.25</td> </tr> <tr> <td>ANGLES</td> <td>±</td> </tr> <tr> <td>FINISH</td> <td>±</td> </tr> </table>		0 PLC	±0.25	1 PLC	±0.25	2 PLC	±0.25	3 PLC	±0.25	4 PLC	±0.25	ANGLES	±	FINISH	±	PRODUCT SPEC 108-2186	SIZE A2	CAGE CODE C=1840398
0 PLC	±0.25																	
1 PLC	±0.25																	
2 PLC	±0.25																	
3 PLC	±0.25																	
4 PLC	±0.25																	
ANGLES	±																	
FINISH	±																	
MATERIAL SEE NOTES		APPLICATION SPEC	SCALE NTS	DRAWING NO. 1840398														
WEIGHT -		CUSTOMER DRAWING	SHEET 4	REV D														

# 9G33 GIGABIT CIRCUIT

## LEFT BOARD

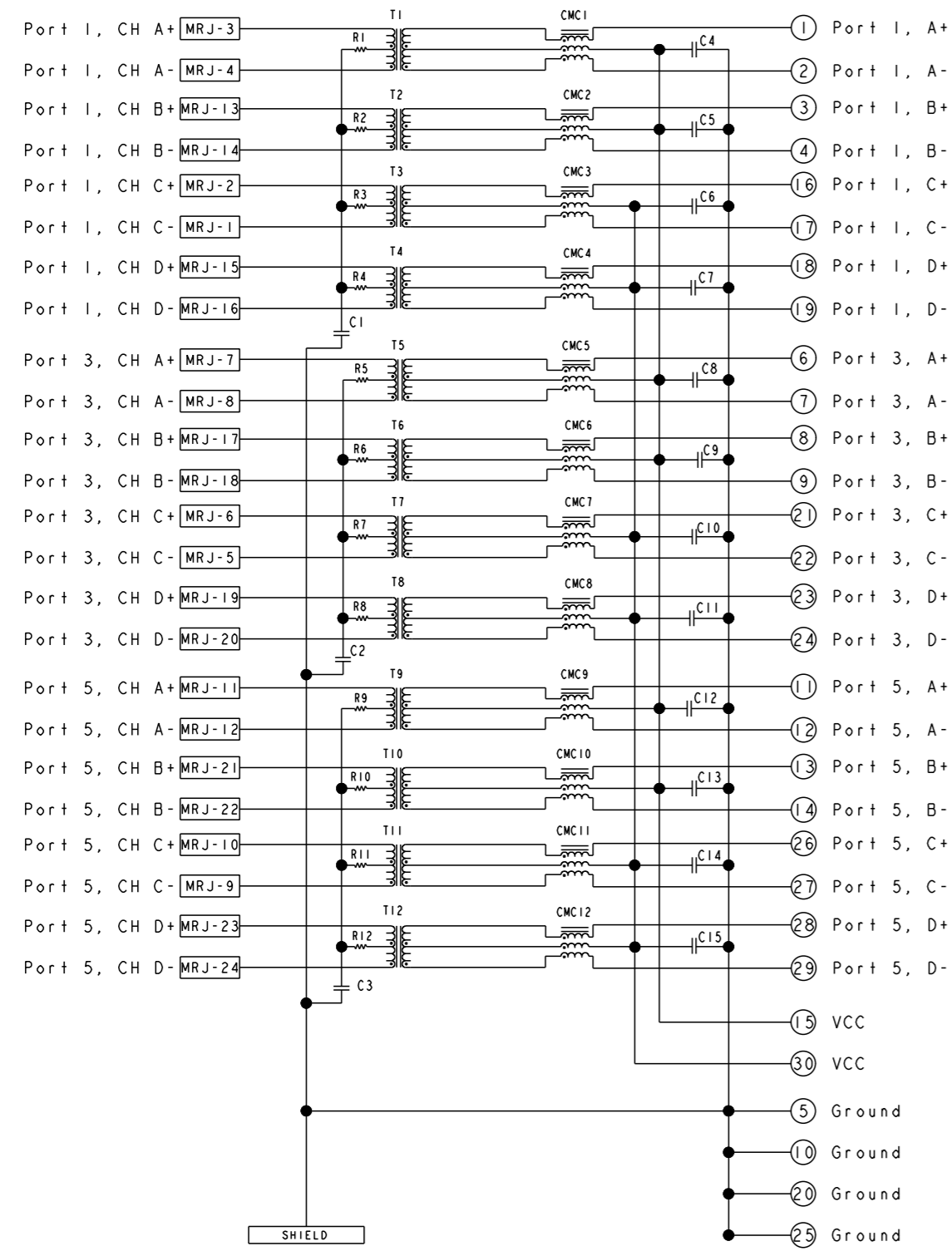

## RIGHT BOARD

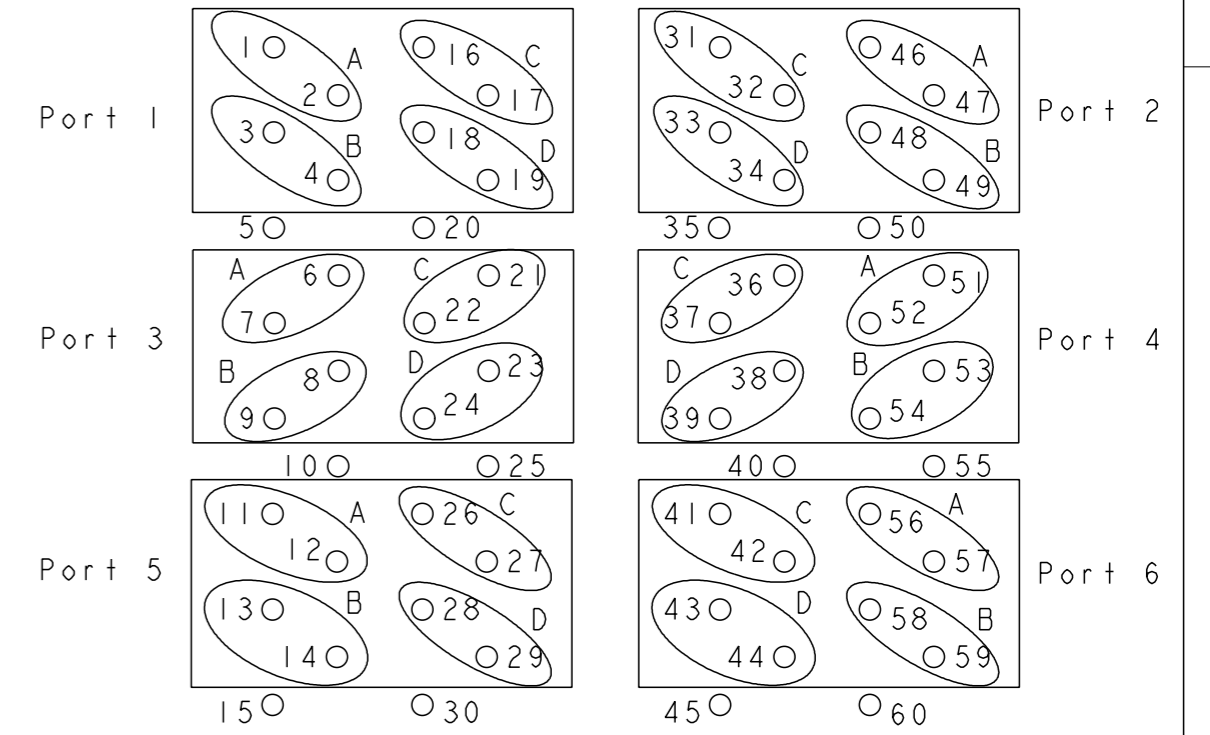
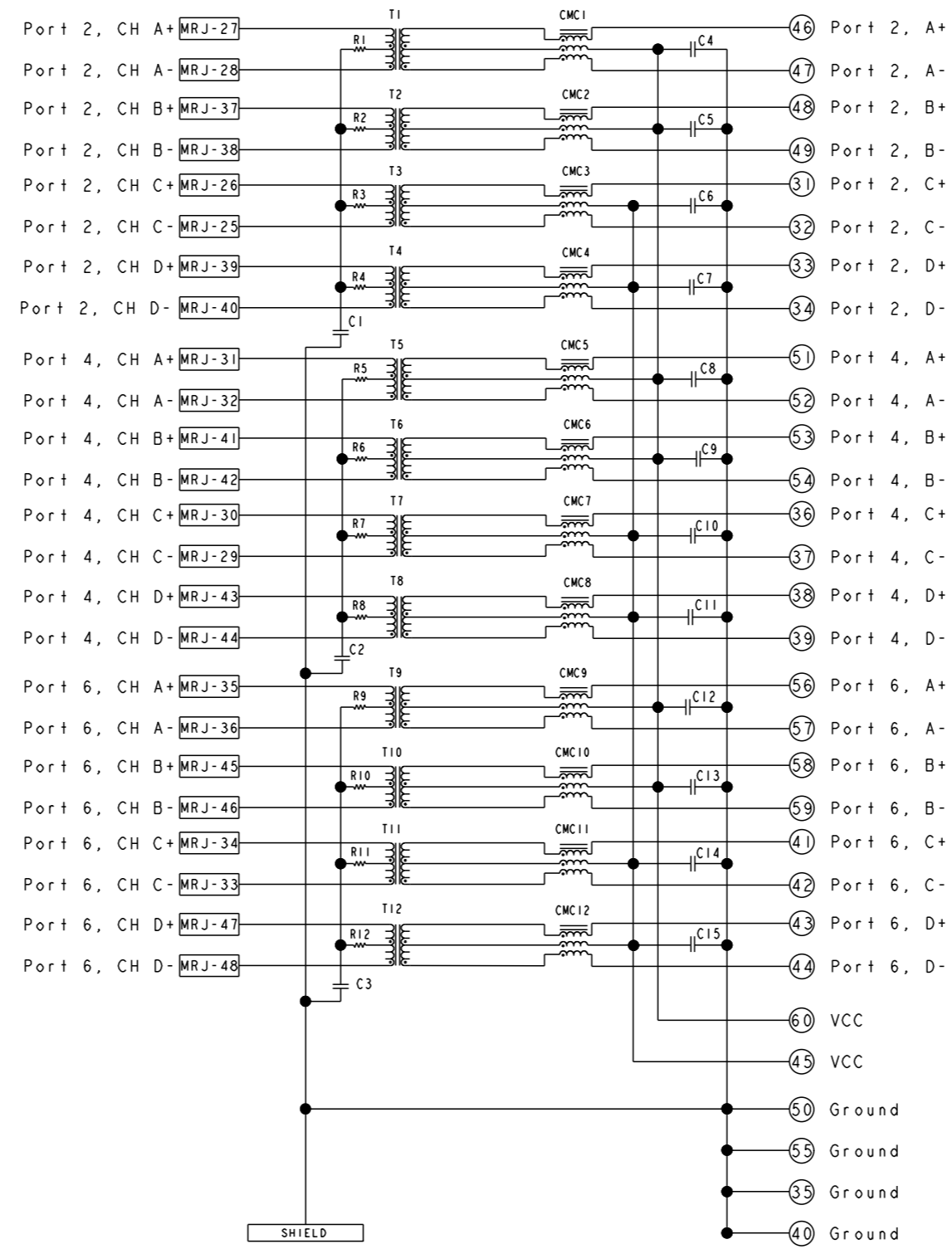

## FOOTPRINT

C1-C3 = 1000pF, 2kV, CAPACITOR  
 C4-C15 = 10 nF, 50V, CAPACITOR  
 R1-R12 = 75 ohms, RESISTOR

THIS DRAWING IS A CONTROLLED DOCUMENT.		DWN TOMMY REN 09MAY2006	 TRP connector Dongguan China
DIMENSIONS: mm		CHK KEITH ZHU 09MAY2006	
TOLERANCES UNLESS OTHERWISE SPECIFIED:		APVD TEDDY XIONG 09MAY2006	
0 PLC ±0.25 1 PLC ±0.25 2 PLC ±0.25 3 PLC ±0.25 4 PLC ± ANGLES ± FINISH ±		PRODUCT SPEC 108-2186 APPLICATION SPEC -	
MATERIAL SEE NOTES		WEIGHT -	NAME 4 POSITION MODULE, NON-OFFSET, NON-POE, MRJ-21, 9G33 CIRCUIT SIZE A2 CAGE CODE C=1840398 DRAWING NO 1840398 RESTRICTED TO -
CUSTOMER DRAWING			SCALE NTS
			SHEET 5 OF 6
			REV D

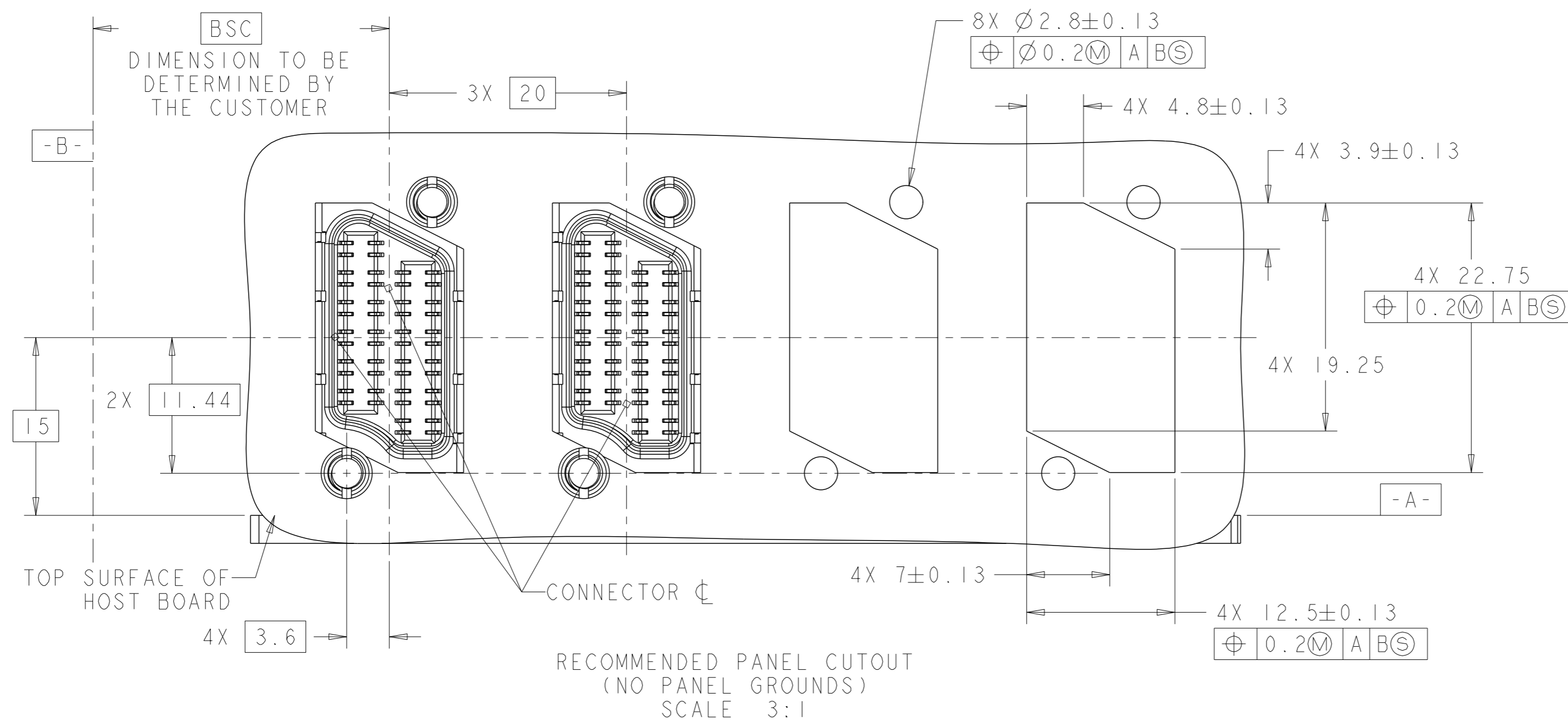

$\nabla$  PANEL THICKNESS

$\nabla$  SCREW LOCKS (8 PLC)

PANEL SHOULD BE MATED TO THE FRONT FACE OF THE HOST BOARD AND SECURE THE CONNECTOR TO THE PANEL WITH SCREW LOCKS TO PROVIDE MAXIMUM STRAIN RELIEF

1840398-1  
SHOWN WITH SCREW LOCKS  
SCALE 3:1

THIS DRAWING IS A CONTROLLED DOCUMENT.		DWN TOMMY REN 09MAY2006	<p>TRP connector Dongguan China</p>													
DIMENSIONS: mm		CHK KEITH ZHU 09MAY2006														
TOLERANCES UNLESS OTHERWISE SPECIFIED:		APVD TEDDY XIONG 09MAY2006														
<table border="1"> <tr><td>0 PLC</td><td><math>\pm 0.25</math></td></tr> <tr><td>1 PLC</td><td><math>\pm 0.25</math></td></tr> <tr><td>2 PLC</td><td><math>\pm 0.25</math></td></tr> <tr><td>3 PLC</td><td><math>\pm 0.25</math></td></tr> <tr><td>4 PLC</td><td><math>\pm 0.25</math></td></tr> <tr><td>ANGLES</td><td><math>\pm</math></td></tr> <tr><td>FINISH</td><td><math>\pm</math></td></tr> </table>		0 PLC		$\pm 0.25$	1 PLC	$\pm 0.25$	2 PLC	$\pm 0.25$	3 PLC	$\pm 0.25$	4 PLC	$\pm 0.25$	ANGLES	$\pm$	FINISH	$\pm$
0 PLC	$\pm 0.25$															
1 PLC	$\pm 0.25$															
2 PLC	$\pm 0.25$															
3 PLC	$\pm 0.25$															
4 PLC	$\pm 0.25$															
ANGLES	$\pm$															
FINISH	$\pm$															
MATERIAL SEE NOTES	SEE NOTES	APPLICATION SPEC -	NAME 4 POSITION MODULE, NON-OFFSET, NON-POE, MRJ-21, 9G33 CIRCUIT													
WEIGHT -		SIZE A2	DRAWING NO C=1840398													
CUSTOMER DRAWING		SCALE NTS	SHEET 6 OF 6 REV D													