

REV.	DESCRIPTION	DATE	APPROVED
A	Engineering Update w/o Changes	02/17/04	M. C.

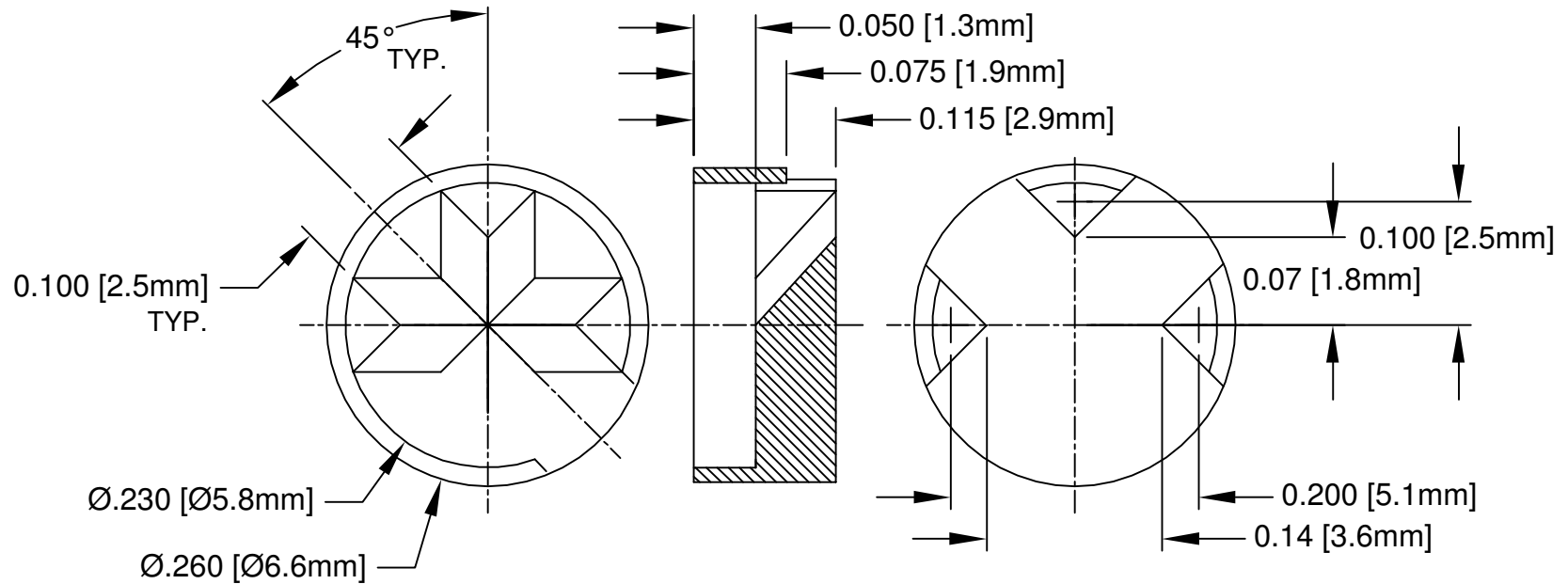

3. MATERIAL: NYLON 6/6, 94V-2, NATURAL. BIVAR MATERIAL CODE 21-NL.
TICONA NYLON 1310, NYLON 6/6, NATURAL.
2. MATERIAL: NYLON 6/6, 94V-2, WHITE. BIVAR MATERIAL CODE 04-WE.
BASF ULTRAMID NYLON 6/6 A3K WHITE.
1. GENERAL SPECIFICATIONS: BIVAR MOLDED COMPONENT SPECIFICATION BV00-E101.

STANDARD TOLERANCE (UNLESS OTHERWISE SPECIFIED)		BIVAR [®]	
DECIMALS	ANGULAR	4 THOMAS, IRVINE, CA. 92618	
.X ±.1	X° ±1°	TEL: (949) 951-8808 FAX: (949) 951-3974	
.XX ±.01		TITLE: PERM-O-PAD TO-18 MOUNT	
.XXX ±.005		PART NO: 200-115	
DESIGNED: Shane Irving	DATE: 07/21/98	REVISION: A	
CHECKED: D. Green	DATE: 02/17/04	CAGE CODE : 32559 SHEET # 1 OF 1	
CAD GENERATED DOCUMENT, DO NOT MEASURE DRAWING.			