

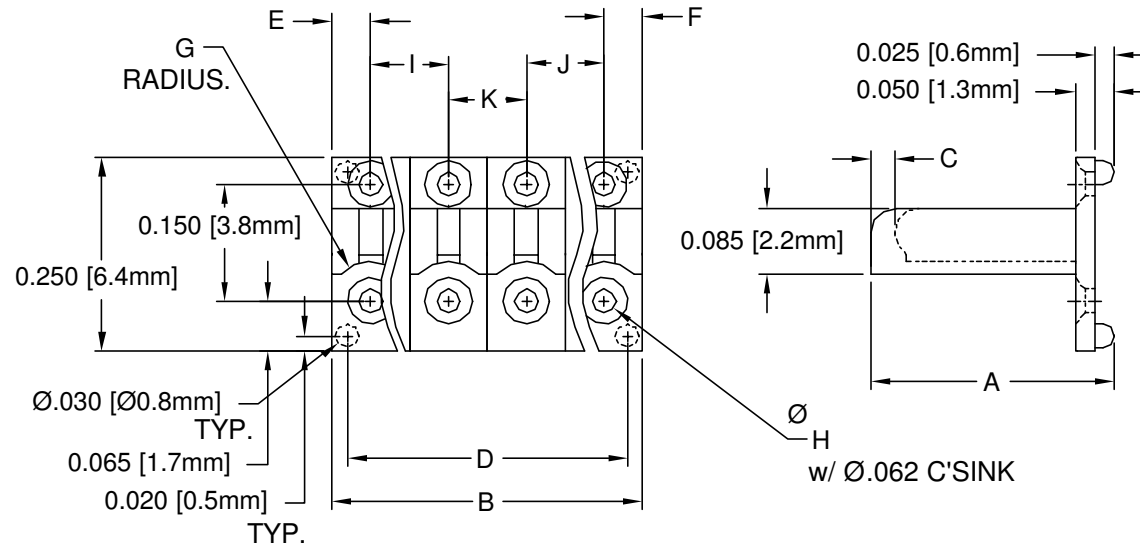

REV.	DESCRIPTION	DATE	APPROVED
C	Engineering Update w/o Changes	03/01/04	M. C.



PART NO.	A	B	C	D	E	F	G	H	I	J	K
3121-004	.312(7.9mm)	0.100(2.5mm)	0.030(0.8mm)	0.060(1.5mm)	0.050(1.3mm)	0.050(1.3mm)	0.055(1.4mm)	0.030(0.8mm)	N/A	N/A	N/A
3122-010	.312(7.9mm)	0.200(5.1mm)	0.030(0.8mm)	0.160(4.1mm)	0.050(1.3mm)	0.050(1.3mm)	0.055(1.4mm)	0.030(0.8mm)	0.100(2.5mm)	N/A	N/A
3123-016	.312(7.9mm)	0.300(7.6mm)	0.030(0.8mm)	0.260(6.6mm)	0.050(1.3mm)	0.050(1.3mm)	0.055(1.4mm)	0.030(0.8mm)	0.100(2.5mm)	0.100(2.5mm)	N/A
3124-022	.312(7.9mm)	0.400(10.2mm)	0.030(0.8mm)	0.360(9.1mm)	0.050(1.3mm)	0.050(1.3mm)	0.055(1.4mm)	0.030(0.8mm)	0.100(2.5mm)	0.100(2.5mm)	0.100(2.5mm)
4371-005	.437(11.1mm)	0.100(2.5mm)	0.030(0.8mm)	0.060(1.5mm)	0.050(1.3mm)	0.050(1.3mm)	0.055(1.4mm)	0.030(0.8mm)	N/A	N/A	N/A
4372-011	.437(11.1mm)	0.200(5.1mm)	0.030(0.8mm)	0.160(4.1mm)	0.050(1.3mm)	0.050(1.3mm)	0.055(1.4mm)	0.030(0.8mm)	0.100(2.5mm)	N/A	N/A
4373-017	.437(11.1mm)	0.300(7.6mm)	0.030(0.8mm)	0.260(6.6mm)	0.050(1.3mm)	0.050(1.3mm)	0.055(1.4mm)	0.030(0.8mm)	0.100(2.5mm)	0.100(2.5mm)	N/A
4374-023	.437(11.1mm)	0.400(10.2mm)	0.030(0.8mm)	0.360(9.1mm)	0.050(1.3mm)	0.050(1.3mm)	0.055(1.4mm)	0.030(0.8mm)	0.100(2.5mm)	0.100(2.5mm)	0.100(2.5mm)
5621-006	.562(14.3mm)	0.150(3.8mm)	0.040(1.0mm)	0.110(2.8mm)	0.075(1.9mm)	0.075(1.9mm)	0.080(2.0mm)	0.040(1.0mm)	N/A	N/A	N/A
5622-012	.562(14.3mm)	0.300(7.6mm)	0.040(1.0mm)	0.260(6.6mm)	0.075(1.9mm)	0.075(1.9mm)	0.080(2.0mm)	0.040(1.0mm)	0.150(3.8mm)	N/A	N/A
5623-018	.562(14.3mm)	0.450(11.4mm)	0.040(1.0mm)	0.410(10.4mm)	0.075(1.9mm)	0.075(1.9mm)	0.080(2.0mm)	0.040(1.0mm)	0.150(3.8mm)	0.150(3.8mm)	N/A
5624-024	.562(14.3mm)	0.600(15.2mm)	0.040(1.0mm)	0.560(14.2mm)	0.075(1.9mm)	0.075(1.9mm)	0.080(2.0mm)	0.040(1.0mm)	0.150(3.8mm)	0.150(3.8mm)	0.150(3.8mm)

2. MATERIAL: POLYESTER/PBT, 30 % GLASS, 94V-0, BLACK. BIVAR MATERIAL CODE 09-BK.
GENERAL ELECTRIC PBT, 30 % GLASS, VALOX 420 SEO, BLACK.
1. GENERAL SPECIFICATIONS: BIVAR MOLDED COMPONENT SPECIFICATION BV00-E101.

STANDARD TOLERANCE (UNLESS OTHERWISE SPECIFIED)		 BIVAR [®] 4 THOMAS, IRVINE, CA. 92618 TEL: (949) 951-8808 FAX: (949) 951-3974	
DECIMALS	ANGULAR		
.X ±.1	X° ±1°	 TITLE: VERTICAL DIODE/RESISTOR MOUNT	
.XX ±.01			
.XXX ±.005			
DESIGNED: Shane Irving	DATE: 06/25/98	PART NO: 31XX-XXX 43XX-XXX 56XX-XXX	REVISION: C
CHECKED: M. Chen	DATE: 09/23/03	CAGE CODE : 32559	SHEET # 1 OF 1
CAD GENERATED DOCUMENT, DO NOT MEASURE DRAWING.			