

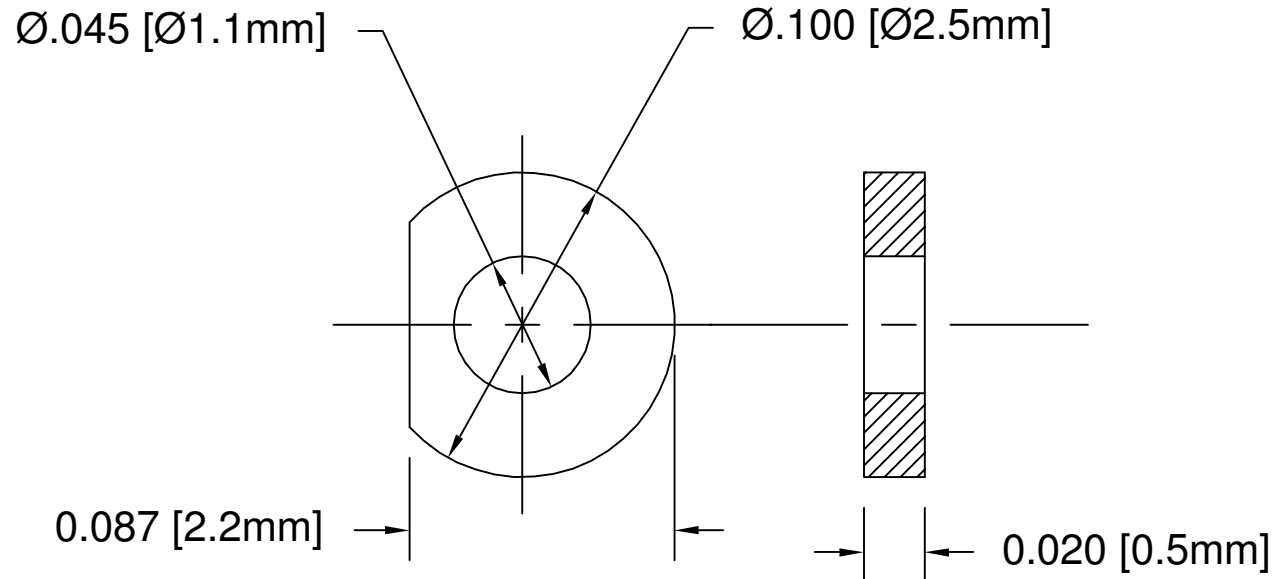

REV.	DESCRIPTION	DATE	APPROVED
C	Engineering Update w/o Changes	02/20/04	M. C.
D	Changed Material From 03-NL to 21-NL	11/11/04	M. C.
E	Corrected Typo.	04/24/07	M. C.
F	Added 25-CR Material Code.	08/14/07	M. C.



3. MATERIAL: POLYESTER FILM, 94VTM-2, CLEAR. BIVAR MATERIAL CODE 25-CR. DUPONT MYLAR-MO, TEIJIN FILM, 94VTM-2, 0.005" THICK, CLEAR.
2. MATERIAL: NYLON 6/6, 94V-2, NATURAL. BIVAR MATERIAL CODE 21-NL. TICONA NYLON 6/6, NYLON 1310 NATURAL.
1. GENERAL SPECIFICATIONS: BIVAR MOLDED COMPONENT SPECIFICATION BV00-E101.

STANDARD TOLERANCE ( UNLESS OTHERWISE SPECIFIED )		 4 THOMAS, IRVINE, CA. 92618 TEL: (949) 951-8808 FAX: (949) 951-3974				
DECIMALS	ANGULAR					
.X ±.1	X° ±1°		TITLE: PERM-O-PAD			
.XX ±.01			DESIGNED: <b>Shane Irving</b>	DATE: 11/02/98	PART NO: 412-020	REVISION: F
.XXX ±.005			CHECKED: <b>M. Chen</b>	DATE: 01/25/02	CAGE CODE : 32559	SHEET # 1 OF 1
				CAD GENERATED DOCUMENT, DO NOT MEASURE DRAWING.		