

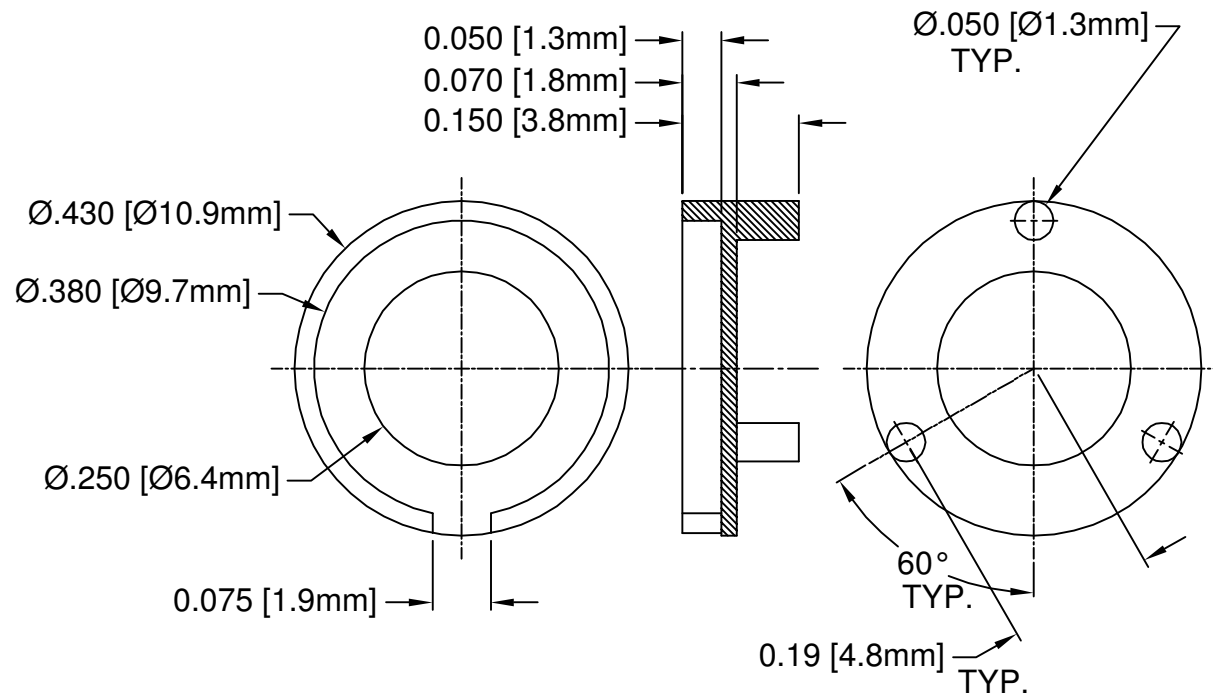

REV.	DESCRIPTION	DATE	APPROVED
A	Engineering Update w/o Changes	02/23/04	M. C.



2. MATERIAL: NYLON 6/6, 94V-2, WHITE. BIVAR MATERIAL CODE 04-WE.  
 BASF ULTRAMID NYLON 6/6 A3K WHITE.
1. GENERAL SPECIFICATIONS: BIVAR MOLDED COMPONENT SPECIFICATION BV00-E101.

STANDARD TOLERANCE (UNLESS OTHERWISE SPECIFIED)		 4 THOMAS, IRVINE, CA. 92618 TEL: (949) 951-8808 FAX: (949) 951-3974	
DECIMALS	ANGULAR	<b>TITLE:</b> PERM-O-PAD TO-5 MOUNT <b>PART NO:</b> 512-150 <b>CAGE CODE :</b> 32559 <b>SHEET #</b> 1 OF 1 <small>CAD GENERATED DOCUMENT. DO NOT MEASURE DRAWING.</small>	
.X $\pm .1$	$X^\circ \pm 1^\circ$		
.XX $\pm .01$			
.XXX $\pm .005$		<b>DESIGNED:</b> Shane Irving <b>CHECKED:</b> D. Green	<b>DATE:</b> 08/04/99 <b>DATE:</b> 02/23/04
		<b>REVISION:</b> A	