

REV.	DESCRIPTION	DATE	APPROVED
A	Engineering Update w/o Changes	02/23/04	M. C.

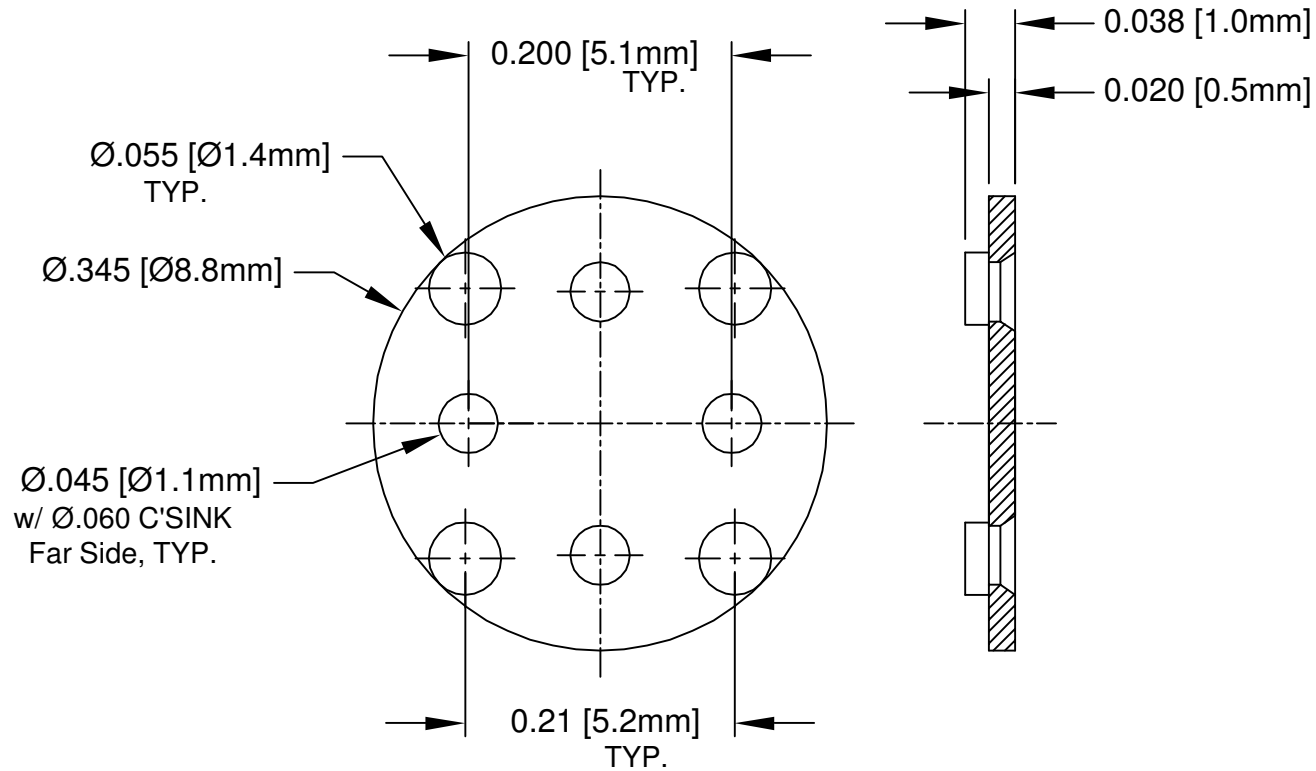

2. MATERIAL: NYLON 6/6, 94V-2, WHITE. BIVAR MATERIAL CODE 04-WE.  
BASF ULTRAMID NYLON 6/6 A3K WHITE.
1. GENERAL SPECIFICATIONS: BIVAR MOLDED COMPONENT SPECIFICATION BV00-E101.

STANDARD TOLERANCE ( UNLESS OTHERWISE SPECIFIED )		BIVAR®	
DECIMALS	ANGULAR	4 THOMAS, IRVINE, CA. 92618	
.X ± .1	X° ± 1°	TEL: (949) 951-8808 FAX: (949) 951-3974	
.XX ± .01		TITLE: PERM-O-PAD TO-5 MOUNT	
.XXX ± .005		DESIGNED: <b>Shane Irving</b>	DATE: <b>05/12/98</b>
		CHECKED: <b>D. Green</b>	DATE: <b>02/23/04</b>
		PART NO: <b>518-038</b>	REVISION: <b>A</b>
		CAGE CODE : <b>32559</b>	SHEET # <b>1 OF 1</b>
		CAD GENERATED DOCUMENT, DO NOT MEASURE DRAWING.	