

REV.	DESCRIPTION	DATE	APPROVED
B	Engineering Update w/o Changes	02/23/04	M. C.
C	Tolerance Update	03/13/06	M. C.
D	Title Description Update	08/03/09	T. Y.

909-235 XX

909-235R XX

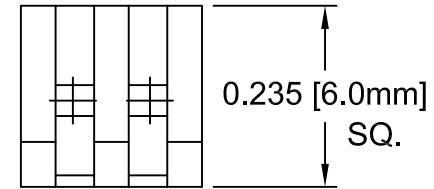

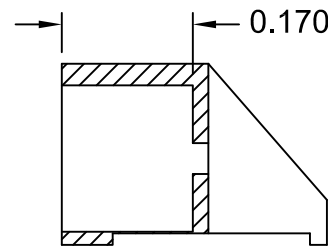
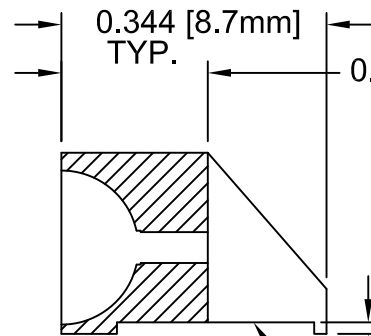
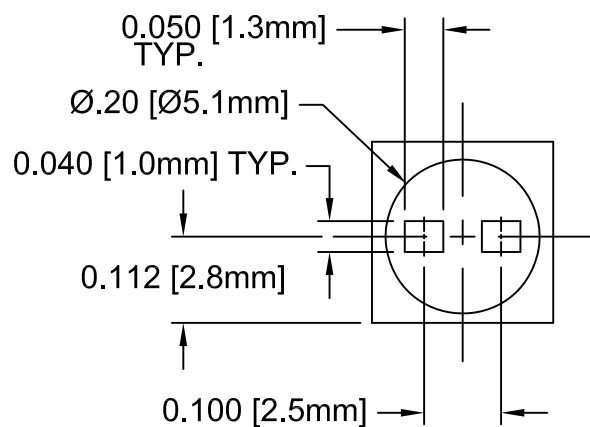

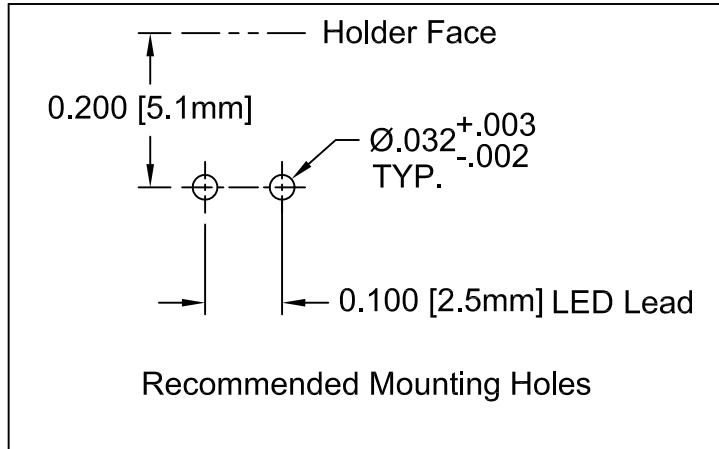
0.015 [0.4mm] TYP.
 Ø.256 [Ø6.5mm] Recess feature to accept 905 series to add height.



HOLDER	MATERIAL CODE
909-235 NT	A
909-235 BK	B
909-235R NT	A
909-235R BK	B

- MATERIAL B: NYLON 6/6, 94V-2, BLACK. BIVAR MATERIAL CODE 03-NL-BK. BASF ULTRAMID NYLON 6/6 A3K NATURAL W/BLACK PIGMENT ADDED.
- MATERIAL A: NYLON 6/6, 94V-2, NATURAL. BIVAR MATERIAL CODE 03-NL. BASF ULTRAMID NYLON 6/6 A3K NATURAL.
- GENERAL SPECIFICATIONS: BIVAR MOLDED COMPONENT SPECIFICATION BV00-E101.

STANDARD TOLERANCE (UNLESS OTHERWISE SPECIFIED)		 4 THOMAS, IRVINE, CA. 92618 TEL: (949) 951-8808 FAX: (949) 951-3974	
DECIMALS	ANGULAR		
.X ±.1	X° ± 1°		
.XX ±.01		 TITLE: SINGLE T1 3/4(5mm) LED HOLDER	
.XXX ±.005			PART NO: 909-235X XX REVISION: D
DESIGNED: David Green	DATE: 04/24/03	CAGE CODE: 32559	SHEET # 1 OF 1
CHECKED: M. Chen	DATE: 04/24/03	CAD GENERATED DOCUMENT. DO NOT MEASURE DRAWING.	