

REV.	DESCRIPTION	DATE	APPROVED
A	Engineering Update w/o Changes	02/24/04	M. C.
B	Typo Correction	10/28/08	T. Y.

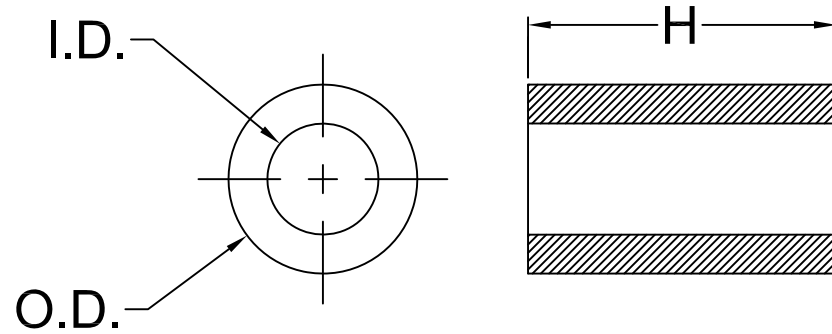

SERIES	SCREW SIZE	I.D.	O.D.	- XXX	H
9913	#2	.091(2.3mm)	.187(4.7mm)	-062	1/16 (1.6mm)
				-125	1/8 (3.2mm)
9910	#2	.091(2.3mm)	.250(6.4mm)	-187	3/16 (4.8mm)
				-250	1/4 (6.4mm)
				-312	5/16 (7.9mm)
9908	#4	.125(3.2mm)	.187(4.7mm)	-375	3/8 (9.5mm)
				-437	7/16 (11.1mm)
				-500	1/2 (12.7mm)
9911	#4	.125(3.2mm)	.250(6.4mm)	-562	9/16 (14.3mm)
				-625	5/8 (15.9mm)
9905	#6	.147(3.7mm)	.250(6.4mm)	-750	3/4 (19.1mm)
				-812	13/16 (20.6mm)
				-875	7/8 (22.2mm)
9912	#8	.171(4.3mm)	.250(6.4mm)	-937	15/16 (23.8mm)
				-1000	1.0 (25.4mm)

3. TOLERANCE "H" DIMENSION:



$H \leq 0.500$  (12.7mm)  $\pm 0.005$  (0.1mm)

$H > 0.500$  (12.7mm)  $\pm 0.010$  (0.3mm)

2. MATERIAL: NYLON 6, ULTRAMID 8270 HS, NATURAL. BIVAR MATERIAL CODE 01-NL-WE.

ALLIED CHEMICAL POLYAMID NYLON 6 WITH CLARIANT CNY02655 WHITE NYLON CONCENTRATE..

1. GENERAL SPECIFICATIONS: BIVAR EXTRUDED PRODUCT SPECIFICATION BV00-E103.

STANDARD TOLERANCE ( UNLESS OTHERWISE SPECIFIED )		 <b>BIVAR</b> <sup>®</sup> 4 THOMAS, IRVINE, CA. 92618 TEL: (949) 951-8808 FAX: (949) 951-3974	
DECIMALS	ANGULAR		
.X $\pm .1$	X° $\pm 1^\circ$	 <b>TITLE:</b> NYLON TUBE SPACERS	
.XX $\pm .01$			
.XXX $\pm .005$			
DESIGNED: <b>Ty Yin</b>	DATE: <b>02/24/04</b>	<b>PART NO:</b> 99XX-XXX	REVISION: <b>B</b>
CHECKED: <b>D. Green</b>	DATE: <b>02/24/04</b>	<b>CAGE CODE :</b> 32559	<b>SHEET # 1 OF 1</b>
CAD GENERATED DOCUMENT, DO NOT MEASURE DRAWING.			