

ITEM	Q'TY	PART NUMBER	PART DESCRIPTION
1	1	C-174	T-1¼ (5mm) LED CLIP
2	1	R-174	T-1¼ (5mm) LED RING

REV.	DESCRIPTION	DATE	APPROVED
B	Engineering Update w/o Changes	02/26/04	M. C.

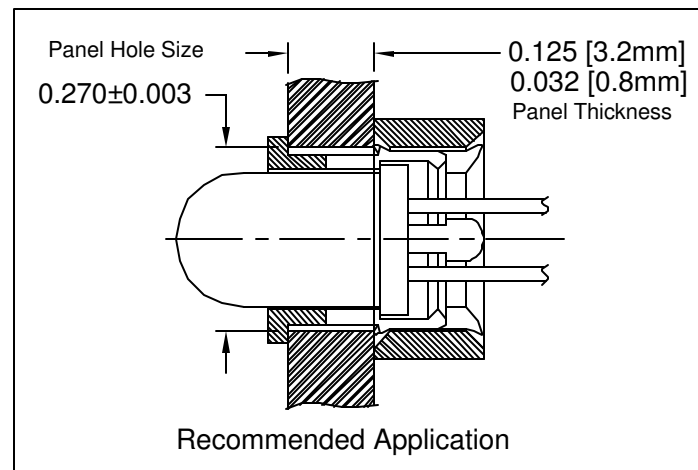
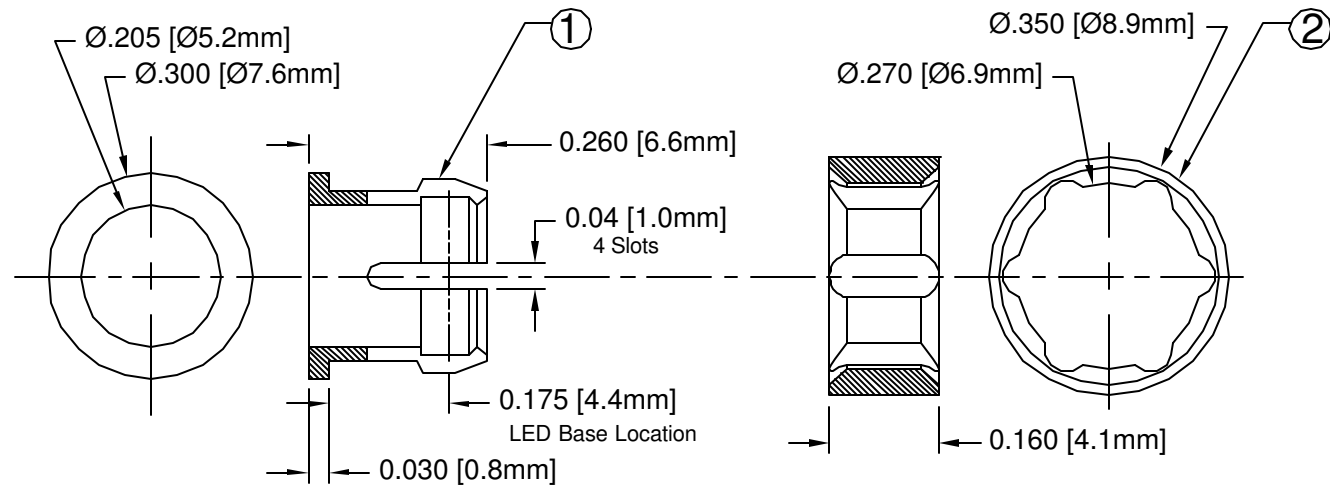

2. MATERIAL: NYLON 6/6, 94V-2, BLACK. BIVAR MATERIAL CODE 03-NL-BK.
 BASF ULTRAMID NYLON 6/6 A3K NATURAL W/BLACK PIGMENT ADDED.
1. GENERAL SPECIFICATIONS: BIVAR MOLDED COMPONENT SPECIFICATION BV00-E101.

STANDARD TOLERANCE (UNLESS OTHERWISE SPECIFIED)		BIVAR®	
DECIMALS	ANGULAR	4 THOMAS, IRVINE, CA. 92618	
.X ±.1	X° ± 1°	TEL: (949) 951-8808 FAX: (949) 951-3974	
.XX ±.01		TITLE: T-1¼ LED CLIP AND RING SET	
.XXX ±.005		DESIGNED: Shane Irving	DATE: 11/24/98
		CHECKED: M. Chen	DATE: 05/17/02
		PART NO: CR-174 REVISION: B CAGE CODE : 32559 SHEET # 1 OF 1 <small>CAD GENERATED DOCUMENT, DO NOT MEASURE DRAWING.</small>	