

REV.	DESCRIPTION	DATE	APPROVED
C	Engineering Update w/o Changes	02/26/04	M. C.
D	Engineering Update w / PPA Version Added	04/18/05	M. C.
E	Engineering Update w / -2 Version Added	08/16/05	M. C.
F	Updated Part No. Table	04/11/06	M. C.
G	Obsolete H-17XC-1 Holder	09/27/07	

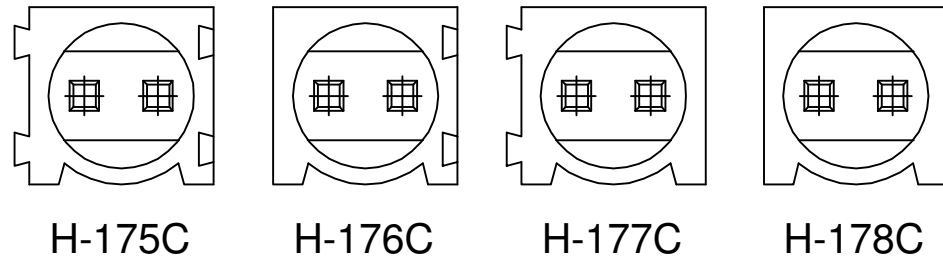
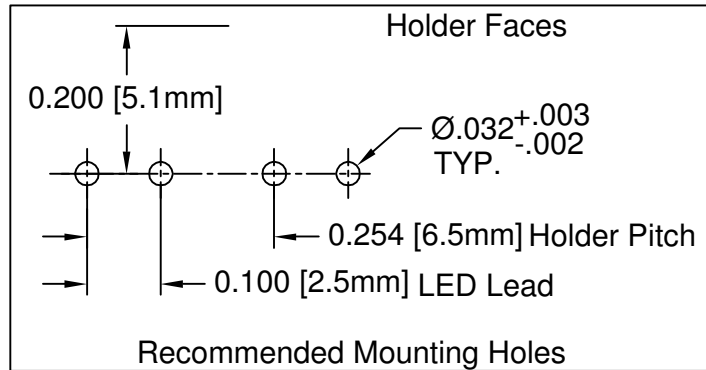
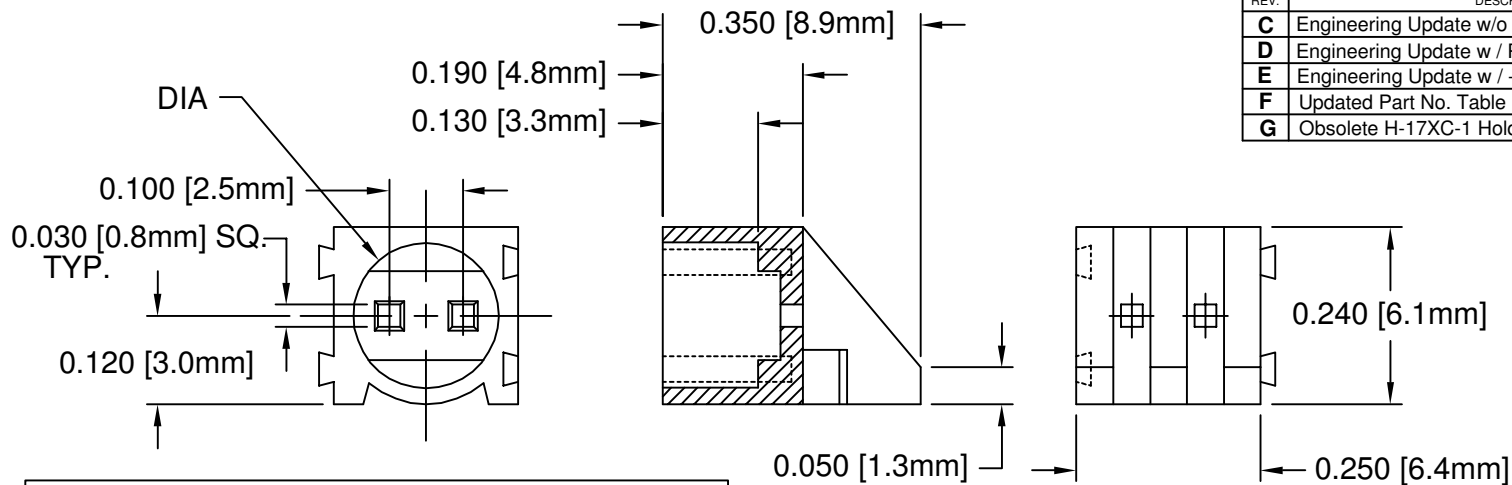

PART NO.				DIA
H-175C SERIES	H-176C SERIES	H-177C SERIES	H-178C SERIES	
H-175C	H-176C	H-177C	H-178C	.197 [5.0mm]
H-175C-2	H-176C-2	H-177C-2	H-178C-2	.206 [5.2mm]+/-0.002"

- STANDARD MATERIAL: NYLON 6/6, 94V-0, BLACK. BIVAR MATERIAL CODE 22-BK. RTP POLYAMIDE NYLON 6/6, 0200 FR, BLACK OR MODIFIED PLASTICS MN6/6-SE BK.
- GENERAL SPECIFICATIONS: BIVAR MOLDED COMPONENT SPECIFICATION BV00-E101.

STANDARD TOLERANCE (UNLESS OTHERWISE SPECIFIED)		BIVAR [®] 4 THOMAS, IRVINE, CA. 92618 TEL: (949) 951-8808 FAX: (949) 951-3974	
DECIMALS	ANGULAR		
.X ±.1	X° ±1°	TITLE: T-1¼ (5mm) LED HOLDER INTERLOCKING VARIABLE DIAMETER	
.XX ±.01			
.XXX ±.005			
DESIGNED: David Green	DATE: 04/18/03	PART NO: H-17XC-X	REVISION: G
CHECKED: M. Chen	DATE: 04/18/03	CAGE CODE : 32559	SHEET # 1 OF 1
CAD GENERATED DOCUMENT, DO NOT MEASURE DRAWING.			