

REV.	DESCRIPTION	DATE	APPROVED
B	Engineering Update w/o Changes	02/26/04	M. C.

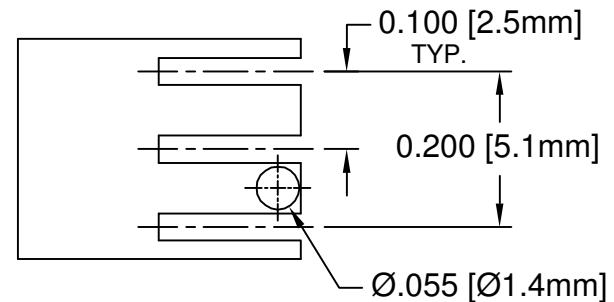
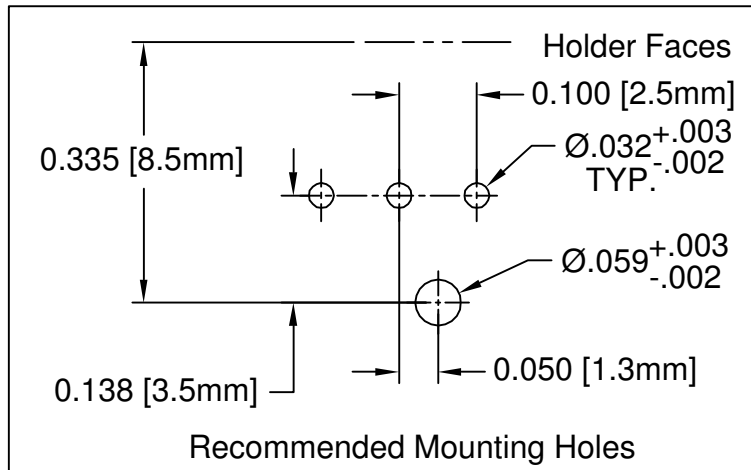
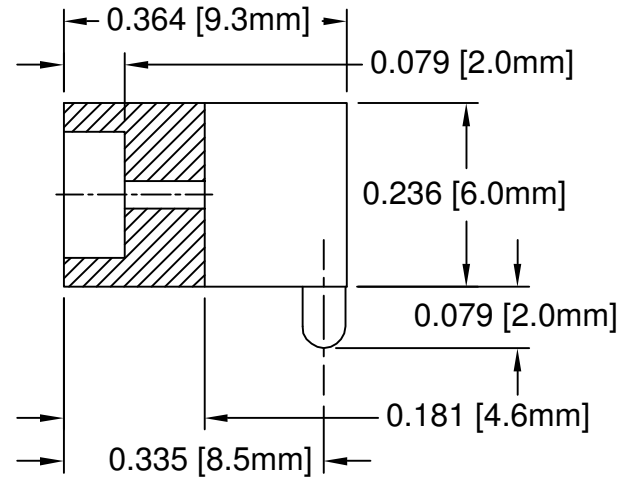
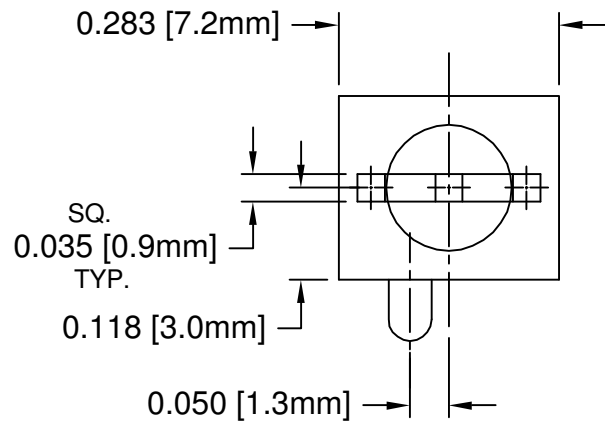

2. MATERIAL: NYLON 6/6, 94V-0, BLACK. BIVAR MATERIAL CODE 22-BK.
RTP POLYAMIDE NYLON 6/6, 0200 FR, BLACK OR MODIFIED PLASTICS MN6/6-SE BK.
1. GENERAL SPECIFICATIONS: BIVAR MOLDED COMPONENT SPECIFICATION BV00-E101.

STANDARD TOLERANCE (UNLESS OTHERWISE SPECIFIED)		BIVAR [®]	
DECIMALS	ANGULAR	4 THOMAS, IRVINE, CA. 92618	
.X ± .1	X° ± 1°	TEL: (949) 951-8808 FAX: (949) 951-3974	
.XX ± .01		TITLE: T-1 (3mm) TRI-LEAD LED HOLDER	
.XXX ± .005		DESIGNED: Shane Irving	DATE: 06/24/02
		CHECKED: M. Chen	DATE: 06/26/02
		PART NO: H-180C-LP	REVISION: B
		CAGE CODE : 32559	SHEET # 1 OF 1
		CAD GENERATED DOCUMENT, DO NOT MEASURE DRAWING.	