

REV.	DESCRIPTION	DATE	APPROVED
B	Engineering Update w/o Changes	02/27/04	M. C.

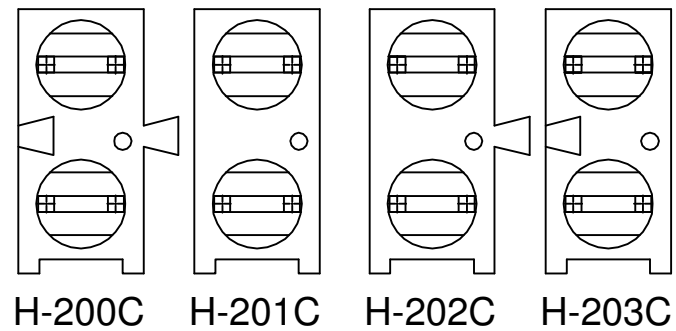
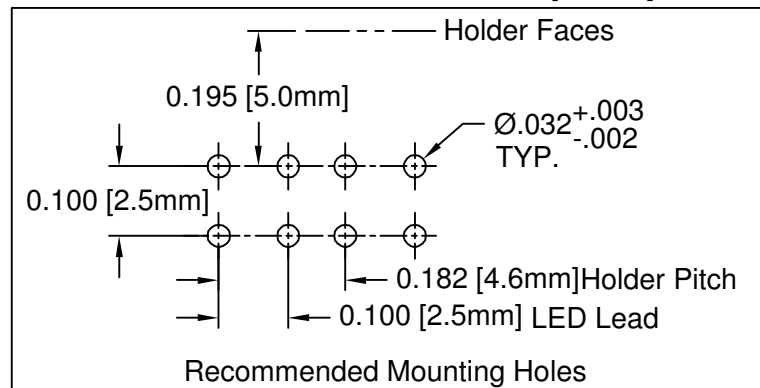
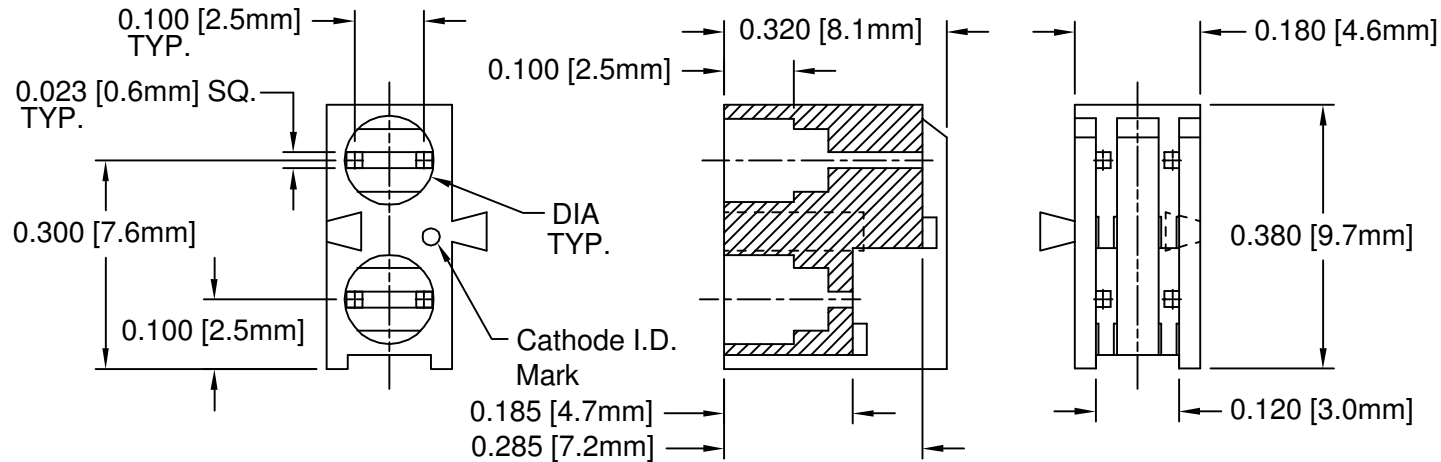

PART NO.				DIA
H-200C SERIES	H-201C SERIES	H-202C SERIES	H-203C SERIES	
H-200C	H-201C	H-202C	H-203C	.128 [3.3mm]
H-200C-1	H-201C-1	H-202C-1	H-203C-1	.150 [3.8mm]

STANDARD TOLERANCE (UNLESS OTHERWISE SPECIFIED)	
DECIMALS	ANGULAR
.X ±.1	X° ±1°
.XX ±.01	
.XXX ±.005	

**BIVAR**<sup>®</sup>  
 4 THOMAS, IRVINE, CA. 92618  
 TEL: (949) 951-8808 FAX: (949) 951-3974

**TITLE:** BI-LEVEL T-1 (3mm) LED HOLDER  
 INTERLOCKING VARIABLE DIAMETER

**PART NO:** H-20XC-X **REVISION:** B

**CAGE CODE :** 32559 **SHEET #** 1 **OF** 1

CAD GENERATED DOCUMENT, DO NOT MEASURE DRAWING.

2. MATERIAL: NYLON 6/6, 94V-0, BLACK. BIVAR MATERIAL CODE 22-BK.  
 RTP POLYAMIDE NYLON 6/6, 0200 FR, BLACK OR MODIFIED PLASTICS MN6/6-SE BK.
1. GENERAL SPECIFICATIONS: BIVAR MOLDED COMPONENT SPECIFICATION BV00-E101.

DESIGNED: <b>David Green</b>	DATE: <b>03/13/03</b>
CHECKED: <b>M. Chen</b>	DATE: <b>03/13/03</b>