

REV.	DESCRIPTION	DATE	APPROVED
D	Engineering Update w/o Changes	02/27/04	M. C.
E	Add [-2] version to the series.	04/13/06	M. C.
F	-1 version Obsolete	10/04/07	M. C.
G	Updated (0.50") Height Dimension	03/04/08	M. C.

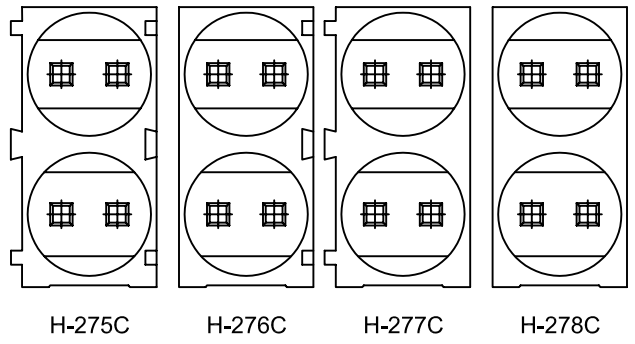
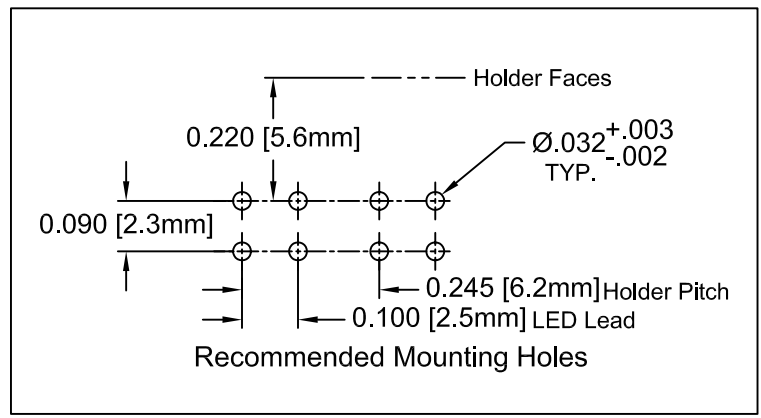
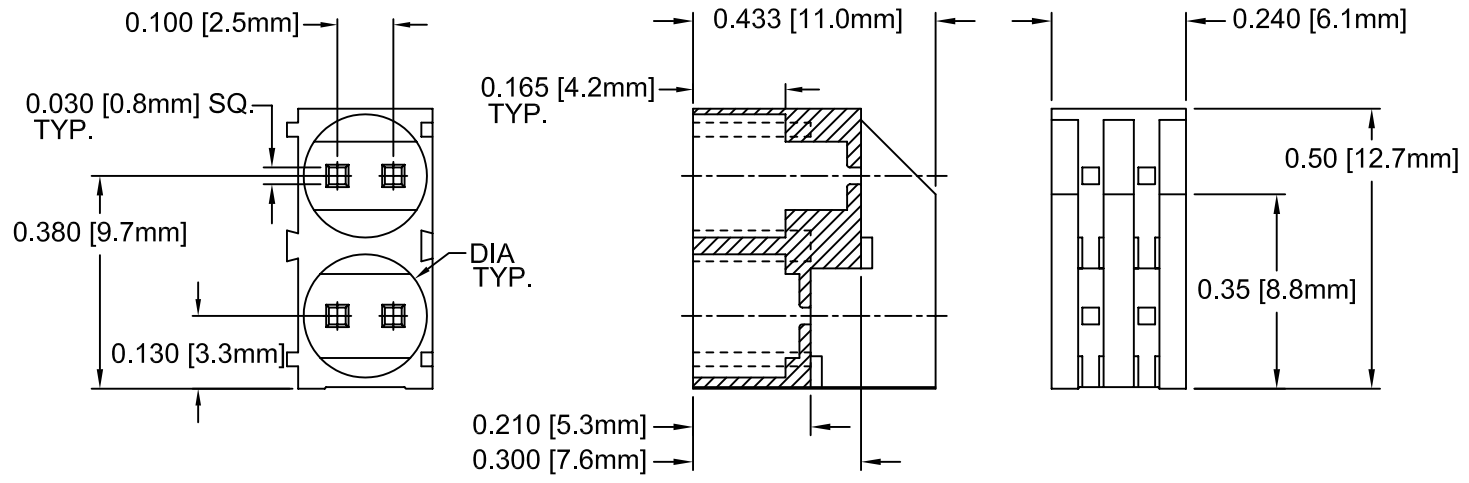

PART NO.				DIA
H-275C SERIES	H-276C SERIES	H-277C SERIES	H-278C SERIES	
H-275C-2	H-276C-2	H-277C-2	H-278C-2	.206 [5.23mm]

- MATERIAL: NYLON 6/6, 94V-0, BLACK. BIVAR MATERIAL CODE 22-BK. RTP POLYAMIDE NYLON 6/6, 0200 FR, BLACK OR MODIFIED PLASTICS MN6/6-SE BK.
- GENERAL SPECIFICATIONS: BIVAR MOLDED COMPONENT SPECIFICATION BV00-E101.

STANDARD TOLERANCE (UNLESS OTHERWISE SPECIFIED)		 BIVAR [®] 4 THOMAS, IRVINE, CA. 92618 TEL: (949) 951-8808 FAX: (949) 951-3974		
DECIMALS	ANGULAR			
.X ±.1	X° ± 1°	 TITLE: BI-LEVEL T-1¼ (5mm) LED HOLDER INTERLOCKING VARIABLE INSIDE DIAMETER		
.XX ±.01				
.XXX ±.005		DESIGNED: Michael Chen	DATE: 03/31/03	PART NO: H-27XC-X REVISION: G
		CHECKED: D. Green	DATE: 03/31/03	