

REV.	DESCRIPTION	DATE	APPROVED
B	Engineering Update w/o Changes	02/27/04	M. C.

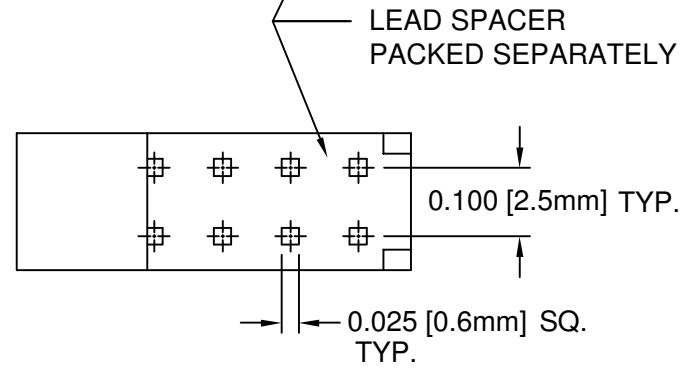
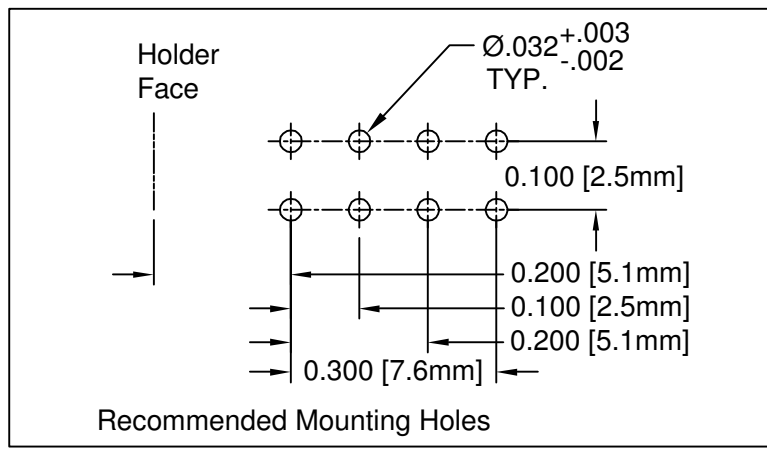
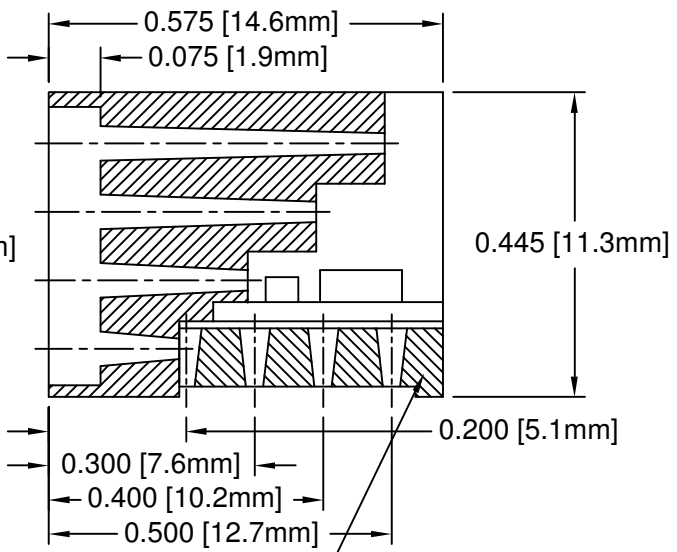
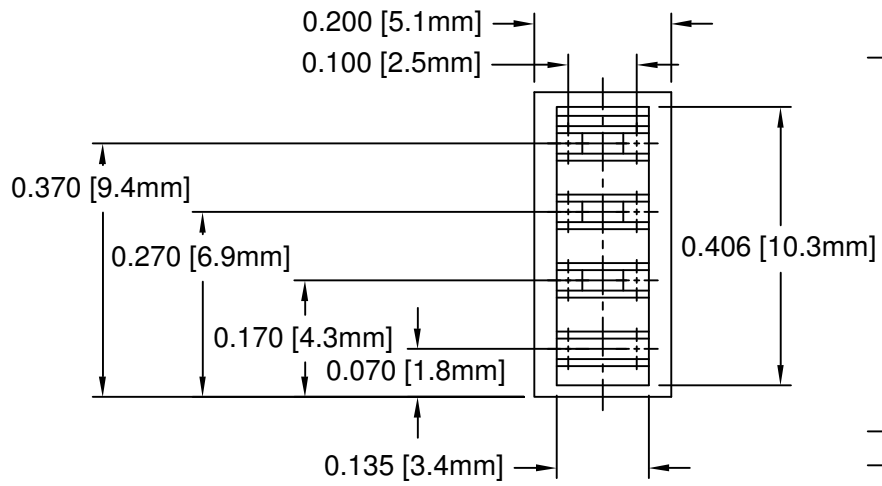

- MATERIAL: NYLON 6/6, 94V-0, BLACK. BIVAR MATERIAL CODE 22-BK. RTP POLYAMIDE NYLON 6/6, 0200 FR, BLACK OR MODIFIED PLASTICS MN6/6-SE BK.
- GENERAL SPECIFICATIONS: BIVAR MOLDED COMPONENT SPECIFICATION BV00-E101.

STANDARD TOLERANCE (UNLESS OTHERWISE SPECIFIED)		 BIVAR [®] 4 THOMAS, IRVINE, CA. 92618 TEL: (949) 951-8808 FAX: (949) 951-3974	
DECIMALS	ANGULAR		
.X ± .1	X° ± 1°	 TITLE: 2mm 90° QUAD LEVEL ASSEMBLY	REVISION: B
.XX ± .01			
.XXX ± .005		PART NO: H-441C	SHEET # 1 OF 1
DESIGNED: Shane Irving	DATE: 02/06/02	CAGE CODE : 32559	CAD GENERATED DOCUMENT. DO NOT MEASURE DRAWING.
CHECKED: M. Chen	DATE: 02/06/02		