

REV.	DESCRIPTION	DATE	APPROVED
G	Engineering Release.	09/01/04	M. C.

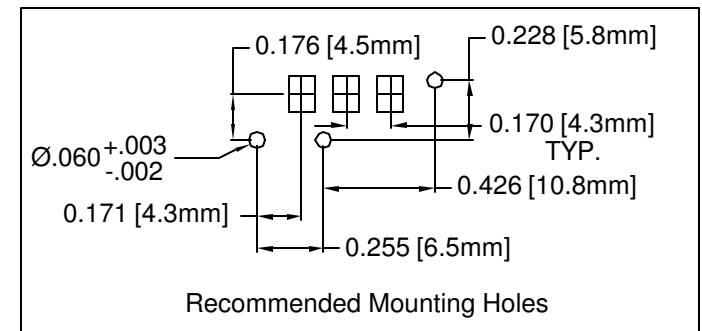
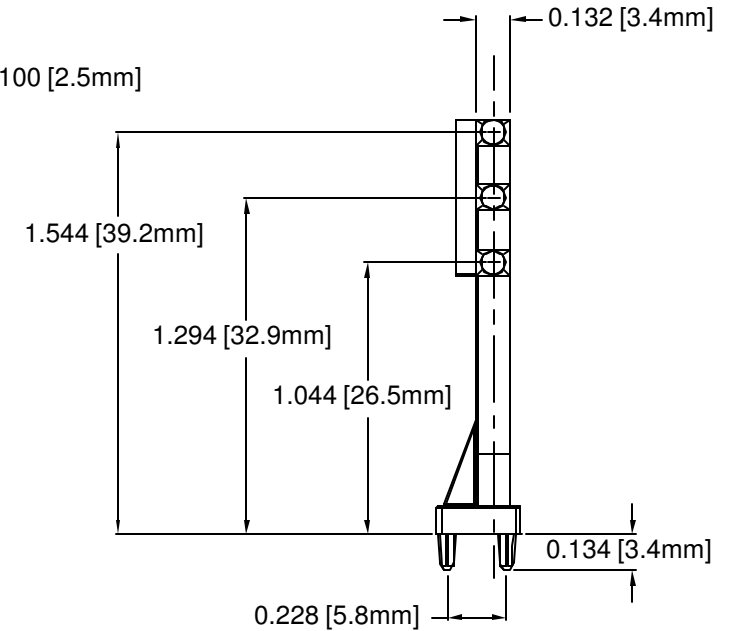
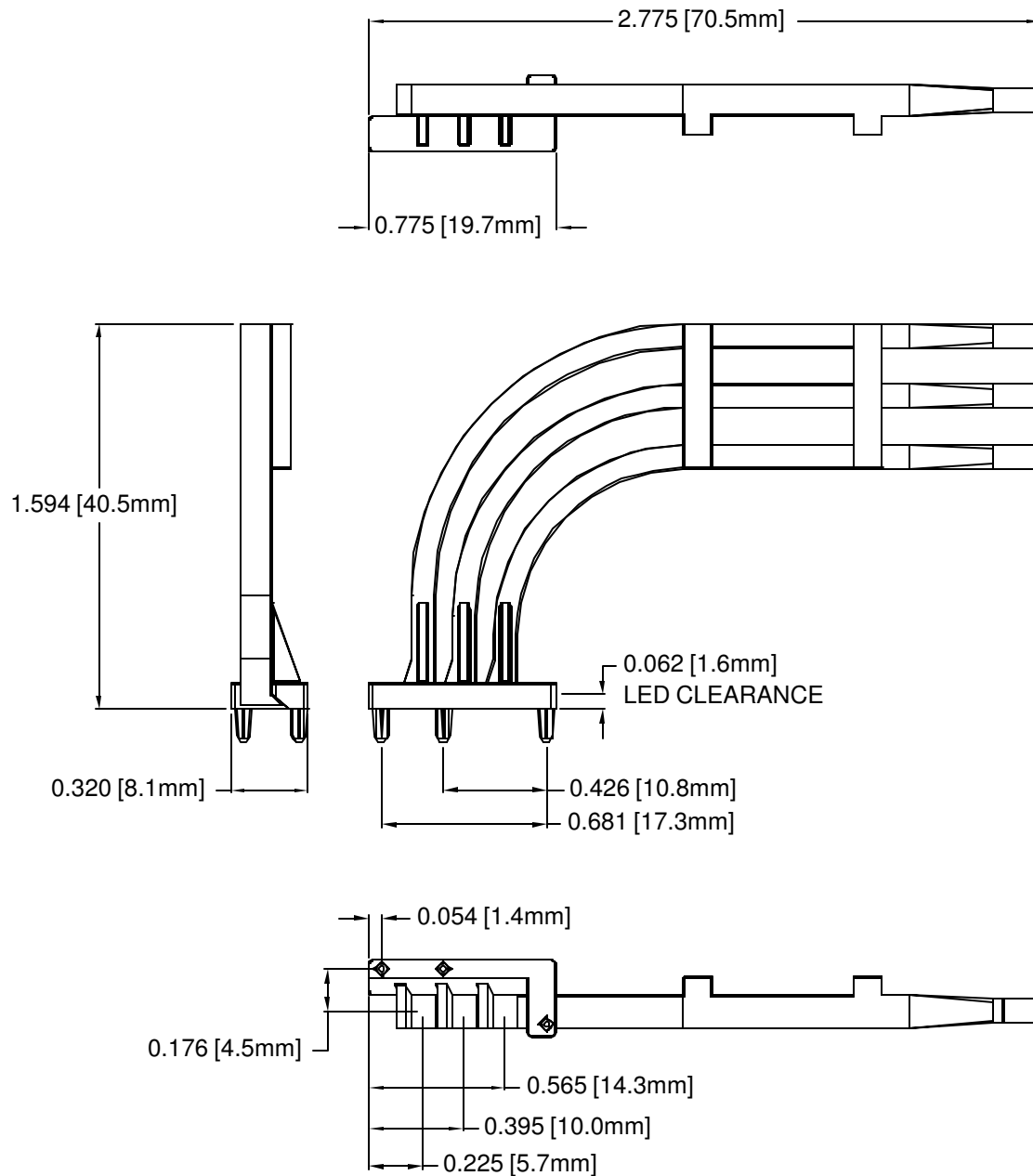

STANDARD TOLERANCE (UNLESS OTHERWISE SPECIFIED)	
DECIMALS	ANGULAR
.X ± .1	X° ± 1°
.XX ± .01	
.XXX ± .005	

BIVAR®

4 THOMAS, IRVINE, CA. 92618
TEL: (949) 951-8808 FAX: (949) 951-3974

TITLE:
CUSTOM LIGHT PIPE, 3 HIGH

DESIGNED: Michael Chen	DATE: 04/07/04
CHECKED: T. Yin	DATE: 04/07/04

PART NO: LP-330	REVISION: G
CAGE CODE : 32559	SHEET # 1 OF 1
CAD GENERATED DOCUMENT. DO NOT MEASURE DRAWING.	

2. MATERIAL: POLYCARBONATE, 94V-0, CLEAR. BIVAR MATERIAL CODE 47-CR.
SAM YANG CORPORATION POLYCARBONATE 3025N2 CLEAR.

1. GENERAL SPECIFICATIONS: BIVAR MOLDED COMPONENT SPECIFICATION BV00-E101.