

REV.	DESCRIPTION	DATE	APPROVED
D	Engineering Update w/o Changes	02/27/04	M. C.
E	Changed LTM Material from 44-BK to 56-BK	06/27/07	M. C.

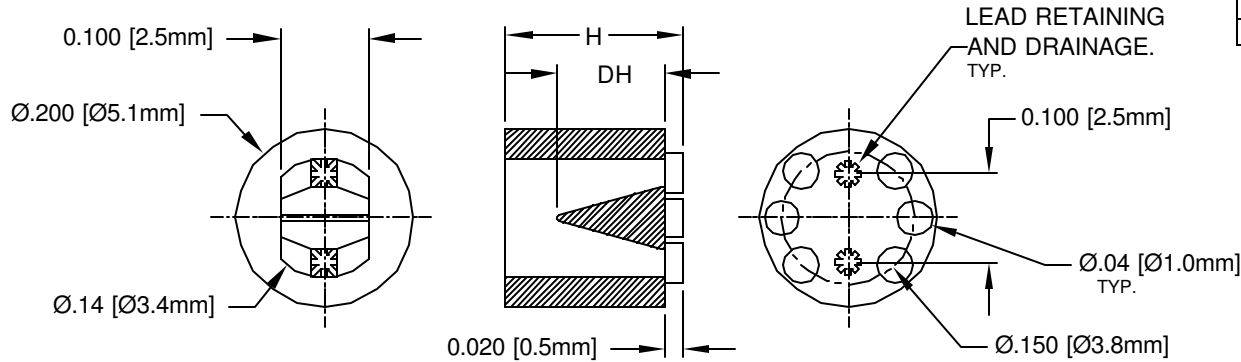

PART NO.	H	DH
LTM / NTM-120	.120(3.1)	.060(1.5)
LTM / NTM-130	.130(3.3)	
LTM / NTM-140	.140(3.6)	
LTM / NTM-150	.150(3.8)	
LTM / NTM-160	.160(4.1)	
LTM / NTM-170	.170(4.3)	
LTM / NTM-180	.180(4.6)	
LTM / NTM-190	.190(4.8)	
LTM / NTM-200	.200(5.1)	
LTM / NTM-210	.210(5.3)	
LTM / NTM-220	.220(5.6)	
LTM / NTM-230	.230(5.8)	
LTM / NTM-240	.240(6.1)	
LTM / NTM-250	.250(6.4)	
LTM / NTM-260	.260(6.6)	
LTM / NTM-270	.270(6.9)	
LTM / NTM-280	.280(7.1)	
LTM / NTM-290	.290(7.4)	

PART NO.	H	DH
LTM / NTM-300	.300(7.6)	.185(4.7)
LTM / NTM-310	.310(7.9)	
LTM / NTM-320	.320(8.1)	
LTM / NTM-330	.330(8.4)	
LTM / NTM-340	.340(8.6)	
LTM / NTM-350	.350(8.9)	
LTM / NTM-360	.360(9.1)	
LTM / NTM-370	.370(9.4)	
LTM / NTM-380	.380(9.7)	
LTM / NTM-390	.390(9.9)	
LTM / NTM-400	.400(10.2)	
LTM / NTM-410	.410(10.4)	
LTM / NTM-420	.420(10.7)	
LTM / NTM-430	.430(10.9)	
LTM / NTM-440	.440(11.2)	
LTM / NTM-450	.450(11.4)	
LTM / NTM-460	.460(11.7)	
LTM / NTM-480	.480(12.2)	

PART NO.	H	DH
LTM / NTM-490	.490(12.5)	.310(7.9)
LTM / NTM-500	.500(12.7)	.435(11.1)
LTM / NTM-520	.520(13.2)	
LTM / NTM-550	.550(14.0)	
LTM / NTM-570	.570(14.5)	
LTM / NTM-600	.600(15.2)	
LTM / NTM-620	.620(15.8)	
LTM / NTM-650	.650(16.5)	
LTM / NTM-670	.670(17.0)	
LTM / NTM-700	.700(17.8)	
LTM / NTM-720	.720(18.3)	
LTM / NTM-750	.750(19.1)	
LTM / NTM-770	.770(19.6)	
LTM / NTM-800	.800(20.3)	
LTM / NTM-820	.820(20.8)	
LTM / NTM-850	.850(21.6)	
LTM / NTM-870	.870(22.1)	
LTM / NTM-900	.900(22.9)	

3. NTM MATERIAL: NYLON 6/6, 94V-2, NATURAL. BIVAR MATERIAL CODE 03-NL.
BASF ULTRAMID NYLON 6/6 A3K NATURAL.
2. LTM MATERIAL: MPPS, 94V-0, BLACK. BIVAR MATERIAL CODE 56-BK.
1. GENERAL SPECIFICATIONS: BIVAR MOLDED COMPONENT SPECIFICATION BV00-E101.

STANDARD TOLERANCE (UNLESS OTHERWISE SPECIFIED)	
DECIMALS	ANGULAR
.X ±.1	X° ±1°
.XX ±.01	
.XXX ±.005	

BIVAR[®]
4 THOMAS, IRVINE, CA. 92618
TEL: (949) 951-8808 FAX: (949) 951-3974

DESIGNED: David Green	DATE: 01/06/03
CHECKED: M. Chen	DATE: 01/06/03

TITLE: MOLDED, SELF-RETAINING LED MOUNT	
PART NO: LTM-NTM-XXX	REVISION: E
CAGE CODE : 32559	SHEET # 1 OF 1
CAD GENERATED DOCUMENT, DO NOT MEASURE DRAWING.	