

REV.	DESCRIPTION	DATE	APPROVED
B	Engineering Update w/o Changes	02/27/04	M. C.
C	Added Mounting Peg Dimension	07/26/13	T. Y.

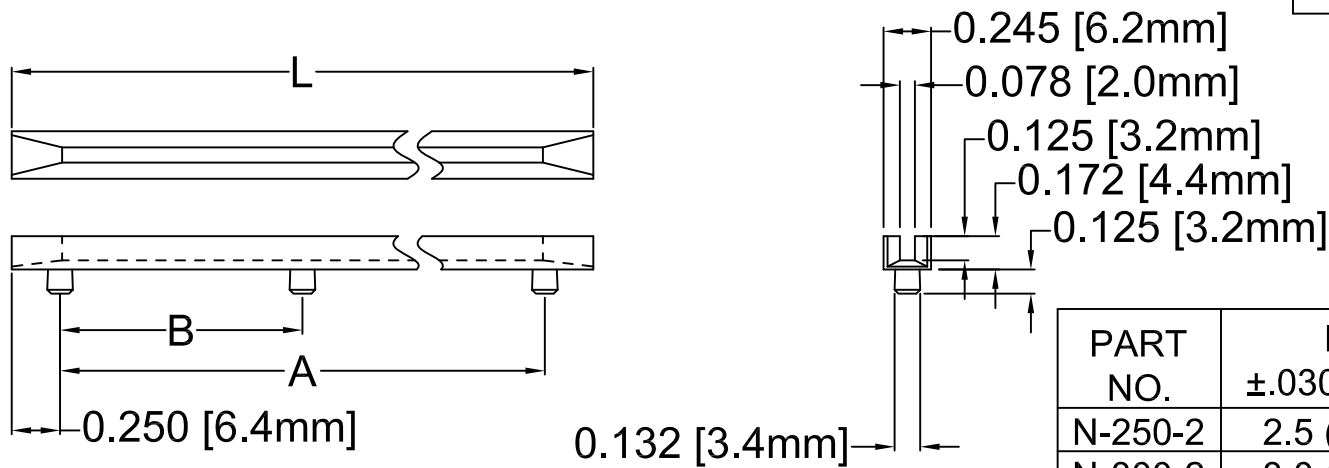

PART NO.	L ±.030 (.76)	A ±.024 (.61)	B ±.016 (.41)
N-250-2	2.5 (63.5)	2.0 (50.8)	--
N-300-2	3.0 (76.2)	2.5 (63.5)	--
N-350-2	3.5 (88.9)	3.0 (76.2)	--
N-400-2	4.0 (101.6)	3.5 (88.9)	--
N-450-2	4.5 (114.3)	4.0 (101.6)	--
N-500-2	5.0 (127.0)	4.5 (114.3)	--
N-550-2	5.5 (139.7)	5.0 (127.0)	--
N-600-2	6.0 (152.4)	5.5 (139.7)	--
N-650-2	6.5 (165.1)	6.0 (152.4)	--
N-700-2	7.0 (177.8)	6.5 (165.1)	--
N-700-3	7.0 (177.8)	6.5 (165.1)	3.25 (82.5)
N-750-2	7.5 (190.5)	7.0 (177.8)	--
N-750-3	7.5 (190.5)	7.0 (177.8)	3.50 (88.9)
N-800-2	8.0 (203.2)	7.5 (190.5)	--
N-800-3	8.0 (203.2)	7.5 (190.5)	3.75 (95.2)
N-850-2	8.5 (215.9)	8.0 (203.2)	--
N-850-3	8.5 (215.9)	8.0 (203.2)	4.00 (101.6)

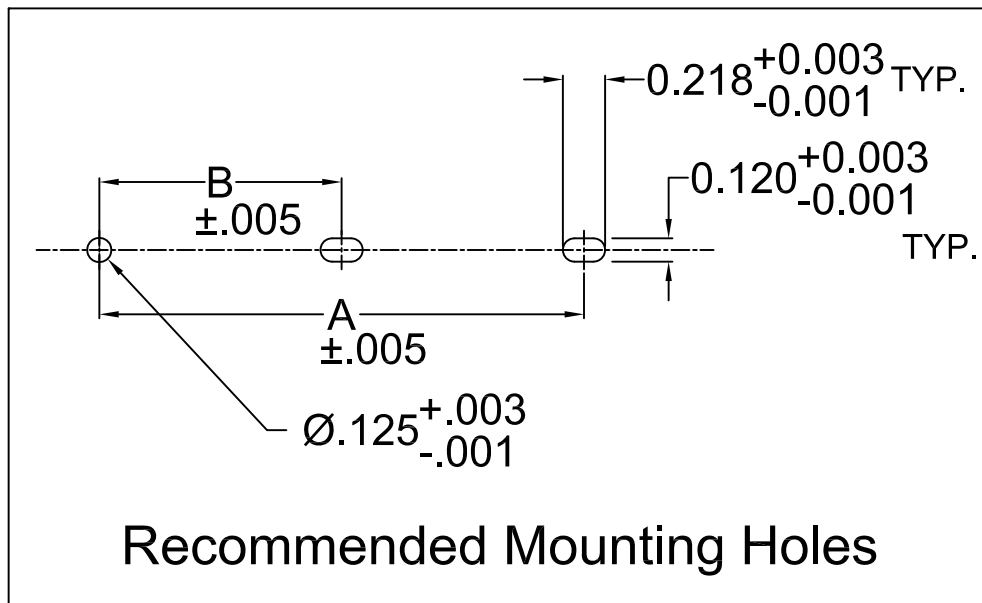

2. MATERIAL: NYLON 6/6, 94V-2, NATURAL. BIVAR MATERIAL CODE 03-NL.  
 1. GENERAL SPECIFICATIONS: BIVAR MOLDED COMPONENT SPECIFICATION BV00-E101.

STANDARD TOLERANCE ( UNLESS OTHERWISE SPECIFIED )		<b>BIVAR</b> <sup>®</sup> 4 THOMAS, IRVINE, CA. 92618 TEL: (949) 951-8808 FAX: (949) 951-3974	
DECIMALS	ANGULAR		
.X ±.1	X° ± 1°	 <b>TITLE:</b> NARROW PRESS-IN CARD GUIDE	
.XX ±.01			
.XXX ±.005			
DESIGNED: <b>David Green</b>	DATE: <b>11/13/02</b>	<b>PART NO:</b> N-XXX-X	REVISION: <b>C</b>
CHECKED: <b>M. Chen</b>	DATE: <b>11/13/02</b>	<b>CAGE CODE :</b> 32559	<b>SHEET # 1 OF 1</b>
CAD GENERATED DOCUMENT, DO NOT MEASURE DRAWING.			