

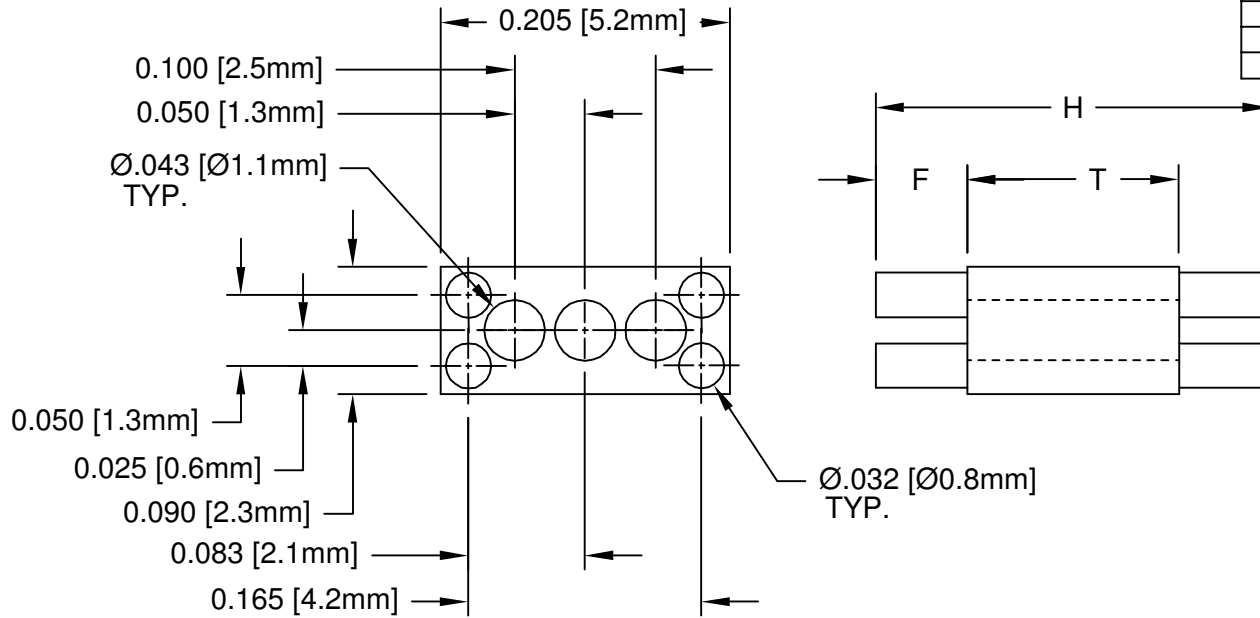

REV.	DESCRIPTION	DATE	APPROVED
A	Engineering Update w/o Changes	02/27/04	M. C.



PART NUMBER	H	T	F
RL4-560	.560 (14.2mm)	0.540 (13.7mm)	0.010 (.25mm)
RL4-580	.580 (14.7mm)		0.020 (.51mm)
RL4-600	.600 (15.2mm)		0.030 (.76mm)
RL4-620	.620 (15.7mm)		0.040 (1.0mm)
RL4-640	.640 (16.3mm)		0.050 (1.3mm)
RL4-660	.660 (16.8mm)		0.060 (1.5mm)
RL4-680	.680 (17.3mm)		0.070 (1.8mm)
RL4-700	.700 (17.8mm)		0.080 (2.0mm)
RL4-720	.720 (18.3mm)		0.090 (2.3mm)
RL4-740	.740 (18.5mm)		0.100 (2.5mm)
RL4-760	.760 (19.3mm)		0.110 (2.8mm)

2. MATERIAL: NYLON 6/6, 94V-0, NATURAL/WHITE. BIVAR MATERIAL CODE 24-WE.
RTP POLYAMIDE NYLON 6/6, 0299X63548, NATURAL OR MODIFIED PLASTICS MN6/6-SE WHT.
1. GENERAL SPECIFICATIONS: BIVAR MOLDED COMPONENT SPECIFICATION BV00-E101.

STANDARD TOLERANCE (UNLESS OTHERWISE SPECIFIED)		 BIVAR [®] 4 THOMAS, IRVINE, CA. 92618 TEL: (949) 951-8808 FAX: (949) 951-3974
DECIMALS	ANGULAR	
.X ±.1	X° ±1°	 TITLE: MOLDED RECTANGULAR LED MOUNT
.XX ±.01		
.XXX ±.005		PART NO: RL4-XXX
DESIGNED: David Green	DATE: 06/06/03	REVISION: A
CHECKED: M. Chen	DATE: 06/06/03	CAGE CODE : 32559 SHEET # 1 OF 1
CAD GENERATED DOCUMENT. DO NOT MEASURE DRAWING.		