

REV.	DESCRIPTION	DATE	APPROVED
B	Engineering Update w/o Changes	03/01/04	M. C.

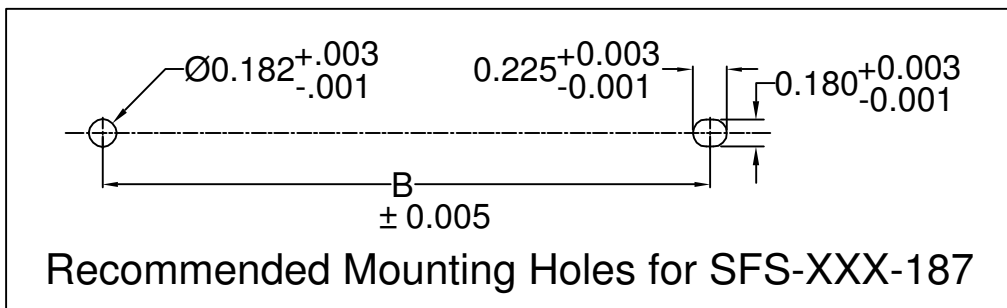
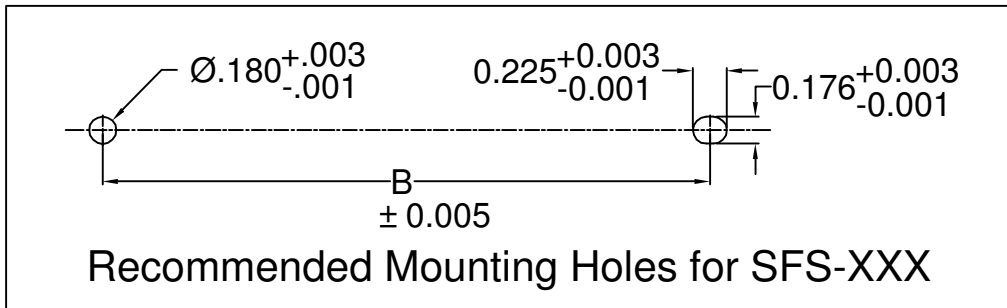
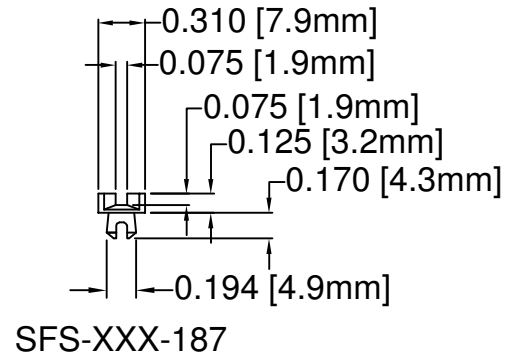
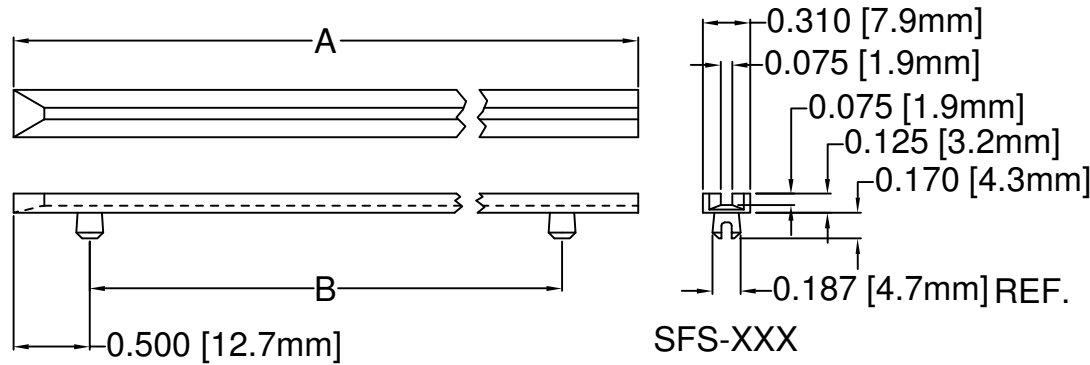

PART NO.		A ±.03 (.79)	B ±.016 (.41)
SFS-250	SFS-250-187	2.5 (63.5)	1.5 (38.1)
SFS-300	SFS-300-187	3.0 (76.2)	2.0 (50.8)
SFS-350	SFS-350-187	3.5 (88.9)	2.5 (63.5)
SFS-400	SFS-400-187	4.0 (101.6)	3.0 (76.2)
SFS-450	SFS-450-187	4.5 (114.3)	3.0 (76.2)
SFS-451	SFS-451-187	4.5 (114.3)	3.5 (88.9)
SFS-500	SFS-500-187	5.0 (127.0)	4.0 (101.6)
SFS-550	SFS-550-187	5.5 (139.7)	4.5 (114.3)
SFS-600	SFS-600-187	6.0 (152.4)	5.0 (127.0)
SFS-650	SFS-650-187	6.5 (165.1)	5.0 (127.0)
SFS-651	SFS-651-187	6.5 (165.1)	5.5 (139.7)
SFS-700	SFS-700-187	7.0 (177.8)	6.0 (152.4)
SFS-750	SFS-750-187	7.5 (190.5)	6.5 (165.1)
SFS-800	SFS-800-187	8.0 (203.2)	7.0 (177.8)

2. MATERIAL: NYLON 6/6, 94V-2, NATURAL. BIVAR MATERIAL CODE 03-NL. BASF ULTRAMID NYLON 6/6 A3K NATURAL.
1. GENERAL SPECIFICATIONS: BIVAR MOLDED COMPONENT SPECIFICATION BV00-E101.

STANDARD TOLERANCE (UNLESS OTHERWISE SPECIFIED)	
DECIMALS	ANGULAR
.X ±.1	X° ±1°
.XX ±.01	
.XXX ±.005	

BIVAR®

4 THOMAS, IRVINE, CA. 92618
TEL: (949) 951-8808 FAX: (949) 951-3974

TITLE:
INTERCHANGEABLE SNAP-IN CARD GUIDE

DESIGNED: Michael Chen	DATE: 12/04/03
CHECKED: D. Green	DATE: 12/04/03

PART NO: SFS-XXX-XXX	REVISION: B
CAGE CODE : 32559	SHEET # 1 OF 1
CAD GENERATED DOCUMENT, DO NOT MEASURE DRAWING.	