

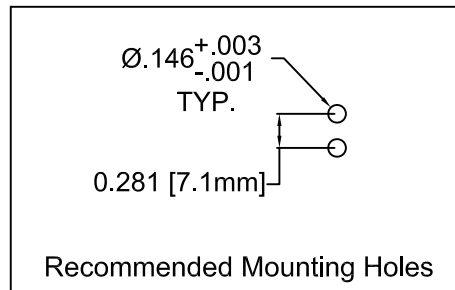

REV.	DESCRIPTION	DATE	APPROVED
B	Engineering Update w/o Changes	03/01/04	M. C.
C	Mounting Hole Update	04/09/09	T. Y.
D	Removed -102 and -134 Parts	08/25/09	T. Y.
E	Tolerance Update on .475" Thickness	09/09/10	T. Y.

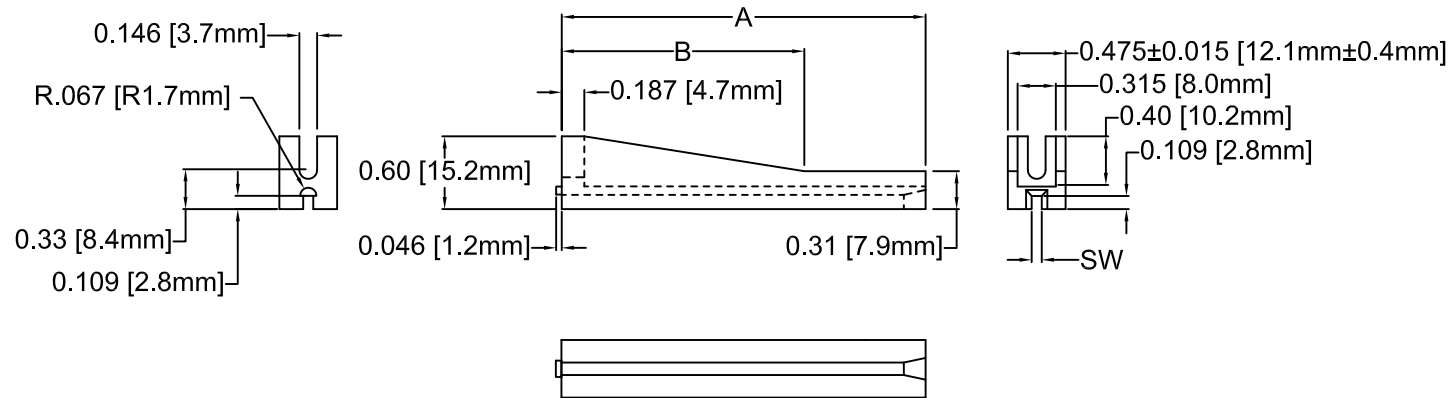

PART NO.	A ±.015 (.38)	B ±.015 (.38)	SW 1/16" PCB
VG2-2	2.0 (50.8)	1.5 (38.1)	.076 (1.9)
VG2-25	2.5 (63.5)	1.5 (38.1)	
VG2-3	3.0 (76.2)	2.0 (50.8)	
VG2-35	3.5 (88.9)		
VG2-4	4.0 (101.6)		
VG2-45	4.5 (114.3)		
VG2-5	5.0 (127.0)		
VG2-55	5.5 (139.7)		
VG2-6	6.0 (152.4)		

2. MATERIAL: NYLON 6, 10% GLASS, 94V-0, BLACK. BIVAR MATERIAL CODE 12-BK.  
RTP 299A X 59354CFR, BLACK OR MODIFIED PLASTICS MN6-FG10SE BK.

1. GENERAL SPECIFICATIONS: BIVAR MOLDED COMPONENT SPECIFICATION BV00-E101.

STANDARD TOLERANCE ( UNLESS OTHERWISE SPECIFIED )		 <b>BIVAR</b> <sup>®</sup> 4 THOMAS, IRVINE, CA. 92618 TEL: (949) 951-8808 FAX: (949) 951-3974	
DECIMALS	ANGULAR		
.X ±.1	X° ± 1°		TITLE: VERTICAL PCB CARD GUIDE
.XX ±.01			PART NO: VG2-XX-XXX
.XXX ±.005		DESIGNED: <b>David Green</b>	REVISION: <b>E</b>
		CHECKED: <b>M. Chen</b>	CAGE CODE : 32559 SHEET # 1 OF 1
		DATE: 11/22/02	CAD GENERATED DOCUMENT, DO NOT MEASURE DRAWING.
		DATE: 11/22/02	