

Evaluation Kit for PA74 Pin-Out

INTRODUCTION

This easy-to-use kit provides a platform for the evaluation of power op amps that use the PA74 pin-out configuration. It can be used to analyze a multitude of standard or proprietary circuit configurations. In addition, it is flexible enough to do most standard amplifier test configurations.

The schematic for 1/2 of the PC board is shown in Figure 2. The schematic for the other half is identical except part reference designators are primed (i.e. R1 = R1'). Note that all of the components shown on the schematic will probably not be used for any single circuit. The component locations on the PC board (See Figure 3) provide maximum flexibility for a variety of configurations. Also included are loops for current probes as well as connection pads on the edge of the PC board for easy interconnects.

The hardware required to mount the PC board and the device under evaluation to the heatsink are included in the kit. Because of the limitless combination of configurations and component values that can be used, no other parts are included in this kit. However, generic formulas and guidelines are included in the Apex Microtechnology DATABOOK and this evaluation kit documentation.

BEFORE YOU GET STARTED

- All Apex Microtechnology amplifiers should be handled using proper ESD precautions!
- Initially set all power supplies to the minimum operating levels allowed in the device data sheet.
- Check for oscillations.
- Always use the heatsink included in this kit with thermal grease or a TW03 and torque the part to the specified 4-7 in-lbs (.45-.79 N•M).
- Do not change connections while the circuit is under power.
- Never exceed any of the absolute maximums listed in the device data sheet.
- Always use adequate power supply bypassing.
- Remember that internal power does not equal load power.
- Do not count on internal diodes to protect the output against sustained, high frequency, high energy kickback pulses.

Figure 1

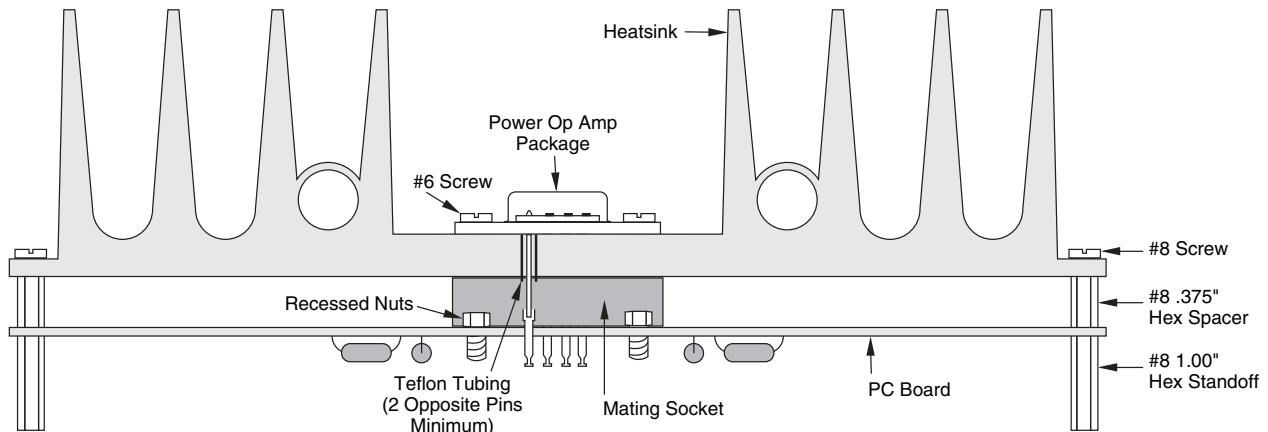

PARTS LIST

Part #	Description	Quantity
HS11	Heatsink	1
EVAL02	PC Board	1
MS03	Mating Socket	2
HWRE01	Hardware Kit	1
TW03	Thermal Washer	1 Box/10

HWRE01 contains the following:

4 #8 Panhead Screw	4 #6 x 1.25" Panhead Screw
4 #8 .375" Hex Spacer	4 #6 x 5/16" Hex Nut
4 #8 1.00" Hex Standoff	2 #6 x 1/4" Hex Nut

ASSEMBLY HINTS

The mating sockets included with this kit have recessed nut sockets for mounting the device under evaluation. This allows assembly from one side of the heatsink, making it easy to swap devices under evaluation. The sizes of the stand-offs were selected to allow proper spacing of the board-to-heatsink and allow enough height for components when the assembly is inverted.

ASSEMBLY

1. Insert a #6 x 5/16" hex nut in each of the nut socket recesses located on the bottom of the mating socket.
2. Insert the socket into the pc board until it is firmly pressed against the ground plane side of the pc board.
3. Solder the socket in place (see Figure 1). Be sure the nuts are in the recesses prior to soldering.
4. Mount the PC board assembly to the heatsink using the stand-offs and spacers included.
5. Apply thermal grease or a TW03 to the bottom of the device under evaluation. Insert into the mating socket through the heatsink.
6. Use the #6 x 1.25" panhead screws to mount the amplifier to the heat sink. Do not overtorque. Recommended mounting torque is 4-7 in-lbs (.45-.79 N•M).

Mounting precautions, general operating considerations, and heatsinking information may be found in the Apex Microtechnology DATA BOOK.

NOTE: Refer to HS11 Heatsink in Accessories section

Figure 2

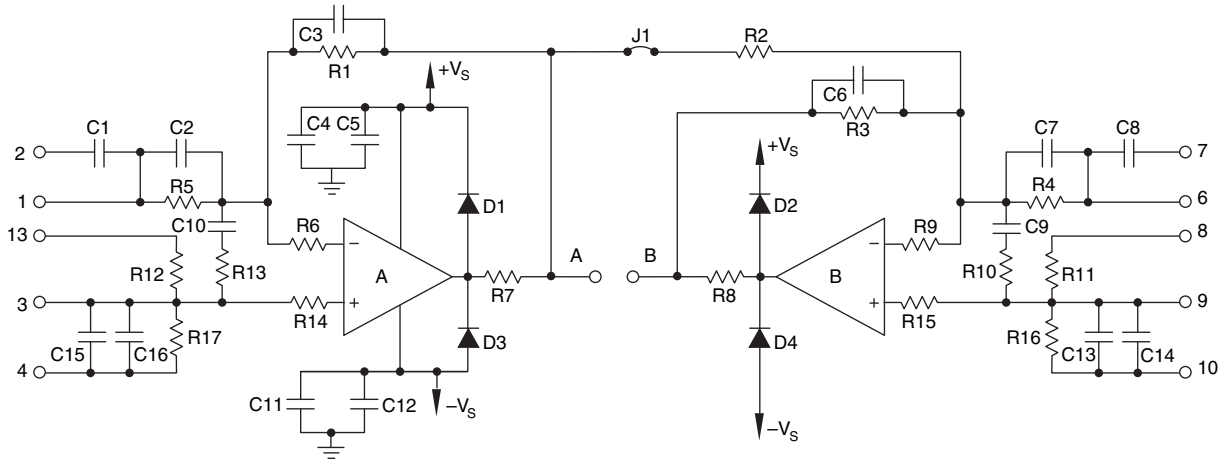

TYPICAL COMPONENT FUNCTIONS

COMPONENT	FUNCTION
R1	Feedback resistor, A side
R2	Input resistor, B side, bridge mode
R3	Feedback resistor, B side
R4	Input resistor, B side
R5	Input resistor, A side
R6	Input bias current measurement (Note 4)
R7	Output current sense resistor or loop for current probe
R8	Output current sense resistor or loop for current probe
R9	Input bias current measurement (Note 4)
R10	Noise gain compensation (Note 1)
R11	Resistor divider network for single supply bias (Note 2)
R12	Resistor divider network for single supply bias (Note 2)
R13	Noise gain compensation (Note 1)
R14	Input bias current measurement
R15	Input bias current measurement
R16	Resistor divider network for single supply bias (Note 2)
R17	Resistor divider network for single supply bias (Note 2)
C1	Input coupling
C2	AC gain set
C3	AC gain or stability (Note 1)
C4	Power supply bypass
C5	Power supply bypass
C6	AC gain or stability (Note 1)
C7	AC gain set
C8	Input coupling
C9	Noise gain compensation (Note 1)
C10	Noise gain compensation (Note 1)
C11	Power supply bypass (Note 3)
C12	Power supply bypass (Note 3)
D1,2,3,4	Flyback protection (Note 5)
C13-16	Bias node noise bypass (Note 2)

Figure 3.

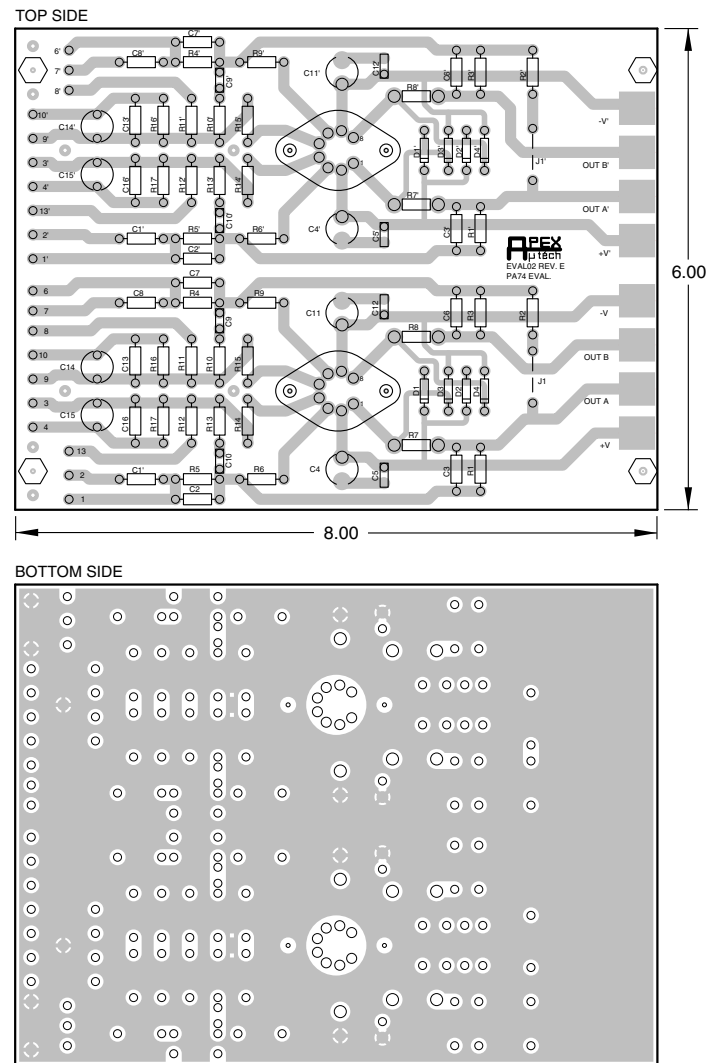

BRIDGE MODE OPERATION

There are two types of bridge mode operation that will be covered in this section; dual (or split) supply and single supply. The PA74 is well suited for both types of bridge mode operation. If another vendor’s pin compatible part is to be compared to the PA74, a close look at output swing and input common mode range is in order. The features that make the PA74 an excellent choice for bridge operation are not included in most other amplifiers. A lack of common mode range may cause permanent damage to other pin compatible parts and the inability of other amplifiers to swing close to the supply rails may cause a lack of available output voltage at the load as well as increase internal dissipation.

The circuit shown in Figure 4 is a dual supply bridge using the “master-slave” configuration. Resistors R 6,7,8,9,14,15 and J1 should be shorts. The available output voltage swing is $V_{SS} - (2 * V_{sat})$. If operating a PA74A at 3 Amps and 30 Volts total supply this translates to:

$$V_{AB}(\max) = 30 - (2 * 3.5) = 23$$

Of course this 23 volts may be applied in either direction across

the load. To set the gain of the circuit you must determine the desired voltage across the load at V_{in} = full scale. Inserting these values into the following equation will yield the ratio of R1 to R5.

$$(V_{AB} / (2 * V_{in})) = R1 / R5$$

The values of R 1,2,3, and 5 should be chosen such that input bias current will not cause an error voltage that is unacceptable. Set R2 equal to R3 to configure the slave amplifier as a unity gain inverter.

Figure 5 shows a typical single supply bridge circuit for an AC coupled input signal. DC coupled inputs may require a different topology to accommodate proper gain and offset terms for a desired transfer function.

The gain and output voltage capability for the single supply bridge are determined the same way as the dual supply bridge (see AN#2). The difference is the bias requirement for the slave amplifier. The noninverting input of the slave amplifier should be biased at mid supply, and must be bypassed.

Figure 4
**Dual
Supply
Bridge**

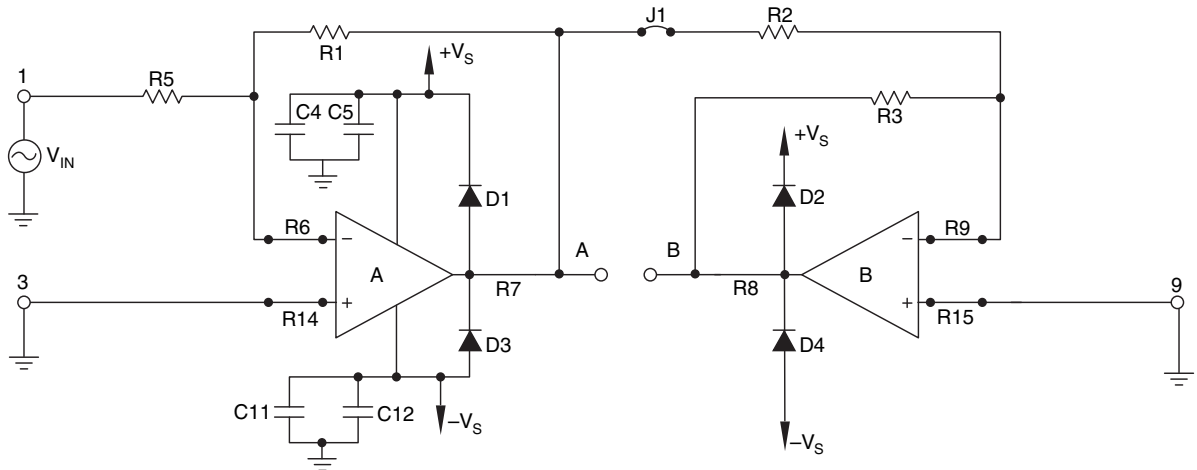
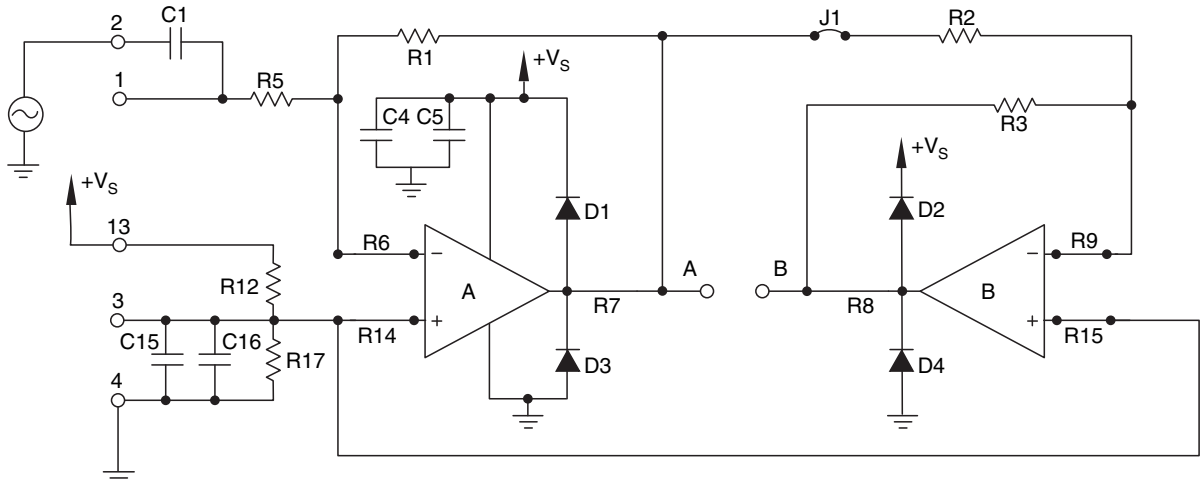

Figure 5
**Single
Supply
Bridge**



HS11 HEATSINK NOTE

The HS11 Heatsink is provided in this evaluation kit to **guarantee** adequate **thermal** design through heat removal from the part under evaluation. Once maximum power dissipation for the application is determined (refer to “General Operating Considerations” and Application Note 11 in the Apex Microtechnology DATA BOOK), the final mechanical design will probably require substantially less heatsinking.

Apex Microtechnology makes no representation that the use or interconnection of the circuits described herein will not infringe on existing or future patent rights, nor do the descriptions contained herein imply the granting of licenses to make, use or sell equipment constructed in accordance therewith.

NOTES: Refer to the following sections of the Apex Microtechnology DATA BOOK as noted.

1. See Stability section of “General Operating Considerations.”
2. See “Gen. Operating Considerations,” and AN3 “Bridge Circuit Drives.”
3. See Power Supplies section of “General Operating Considerations.”
4. See “Parameter Definitions and Test Methods.”
5. See Amplifier Protection section of “Gen. Operating Considerations.”

NEED TECHNICAL HELP? CONTACT APEX SUPPORT!

For all Apex Microtechnology product questions and inquiries, call toll free 800-546-2739 in North America.

For inquiries via email, please contact apex.support@apexanalog.com.

International customers can also request support by contacting their local Apex Microtechnology Sales Representative.

To find the one nearest to you, go to www.apexanalog.com

IMPORTANT NOTICE

Apex Microtechnology, Inc. has made every effort to insure the accuracy of the content contained in this document. However, the information is subject to change without notice and is provided "AS IS" without warranty of any kind (expressed or implied). Apex Microtechnology reserves the right to make changes without further notice to any specifications or products mentioned herein to improve reliability. This document is the property of Apex Microtechnology and by furnishing this information, Apex Microtechnology grants no license, expressed or implied under any patents, mask work rights, copyrights, trademarks, trade secrets or other intellectual property rights. Apex Microtechnology owns the copyrights associated with the information contained herein and gives consent for copies to be made of the information only for use within your organization with respect to Apex Microtechnology integrated circuits or other products of Apex Microtechnology. This consent does not extend to other copying such as copying for general distribution, advertising or promotional purposes, or for creating any work for resale.

APEX MICROTECHNOLOGY PRODUCTS ARE NOT DESIGNED, AUTHORIZED OR WARRANTED TO BE SUITABLE FOR USE IN PRODUCTS USED FOR LIFE SUPPORT, AUTOMOTIVE SAFETY, SECURITY DEVICES, OR OTHER CRITICAL APPLICATIONS. PRODUCTS IN SUCH APPLICATIONS ARE UNDERSTOOD TO BE FULLY AT THE CUSTOMER OR THE CUSTOMER'S RISK.

Apex Microtechnology, Apex and Apex Precision Power are trademarks of Apex Microtechnology, Inc. All other corporate names noted herein may be trademarks of their respective holders.