



VRLA Rechargeable Battery

BPL3.3-12 (BPL3.3-12FR)



FEATURES

- Maintenance free(no water topping-up required).
- No free acid(Non-spillable battery).
- Low self-discharge rate, lower than 3% capacity loss per month.
- Can be used in any orientation(excluding used inverted).
- Absorbent Glass Mat technology for efficient gas recombination.

APPLICATION

- UPS
- Toy-Cars
- Fishing Lights



SPECIFICATIONS

Nominal Voltage	12 V
Nominal Capacity	3.3Ah @ 20 hour rate F.V.(1.75V/cell)
Approx. Weight	1.35Kg(2.98lbs.)
Terminals	T1 (Faston Tab 187) T2 is optional
Internal Resistance	≤50m Ω (Fully Charged)
Max. Discharge Current	49.5 A (5 sec.)
Max. Charge Current	0.99 A
Operating Temperature Range	Charge : 0°C~40°C(32°F~104°F) Discharge : -20°C~50°C(-4°F~122°F) Storage : -20°C~40°C(-4°F~104°F)
Container Material	ABS(UL94-HB, UL94-V0 is optional)

ISO 9001	
ISO14001	
UL	
CE	
<ul style="list-style-type: none"> ● IEC 61056-1 ● JIS C 8702-1 ● GB/T 19639.1 	

DIMENSION(mm/inch)

OUTER DIMENSIONS

TERMINAL TYPE

Length

134±1.5 (5.28±0.06)

Width

67±1.5 (2.64±0.06)

Container Height

60±1.5 (2.36±0.06)

Total Height

66±2.0 (2.60±0.08)

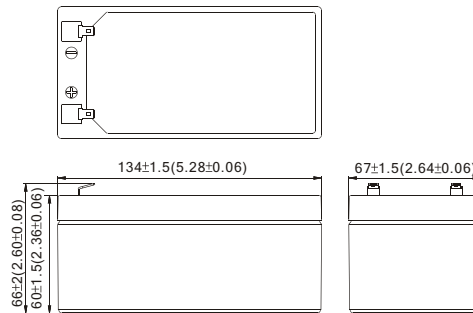

Terminal T1

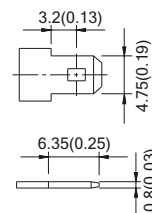

Terminal T2

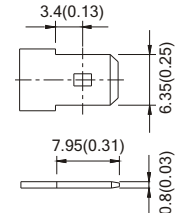

Constant power discharge characteristics at 25 °C/77 °F

Unit: W

F.V. (V/cell) \ Discharge Time	5 Min	10 Min	15 Min	30 Min	1 Hr	3 Hr	5 Hr	10 Hr	20 Hr
1.80V	107.5	80.8	65.4	39.36	22.82	9.62	6.65	3.71	1.94
1.75V	124.5	87.5	68.5	40.87	23.48	9.81	6.74	3.76	1.98
1.70V	132.0	90.7	70.6	41.77	23.90	9.90	6.79	3.78	1.99
1.65V	138.1	92.9	72.2	42.38	24.23	9.99	6.84	3.79	1.99
1.60V	142.4	94.7	73.6	42.81	24.47	10.04	6.84	3.79	1.99

Constant current discharge characteristics at 25 °C/77 °F

Unit: A

F.V. (V/cell) \ Discharge Time	5 Min	10 Min	15 Min	30 Min	1 Hr	3 Hr	5 Hr	10 Hr	20 Hr
1.80V	9.68	7.11	5.69	3.336	1.917	0.801	0.554	0.309	0.161
1.75V	11.42	7.71	5.96	3.464	1.973	0.817	0.562	0.314	0.165
1.70V	12.11	7.98	6.14	3.540	2.009	0.825	0.566	0.315	0.166
1.65V	12.67	8.18	6.28	3.592	2.036	0.833	0.570	0.316	0.166
1.60V	13.06	8.34	6.40	3.628	2.056	0.837	0.570	0.316	0.166

All data shall be changed without prior notice, BB reserves the right to explain and update the information contained hereinto.