



VRLA Rechargeable Battery

BPL110-12 (BPL110-12FR)



FEATURES

- Maintenance free(no water topping-up required).
- No free acid(Non-spillable battery).
- Low self-discharge rate, lower than 3% capacity loss per month.
- Can be used in any orientation(excluding used inverted).
- Filtered with explosion proof filter.
- Flame-arrestor is installed to ensure safety.
- Carry handles for easy installation.
- Absorbent Glass Mat technology for efficient gas recombination

APPLICATION

- UPS
- Telecom
- Telecom



SPECIFICATIONS

Nominal Voltage	12 V
Nominal Capacity	110.0Ah @ 20 hour rate F.V.(1.75V/cell)
Approx. Weight	40.0Kg(88.2lbs.)
Terminals	B4 (Fitting M6 bolt & nut) I2 is optional
Internal Resistance	≤4mΩ (Fully Charged)
Max. Discharge Current	800 A (5 sec.)
Max. Charge Current	33 A
Operating Temperature Range	Charge : 0°C~40°C(32°F~104°F) Discharge : -20°C~50°C(-4°F~122°F) Storage. : -20°C~40°C(-4°F~104°F)
Container Material	ABS(UL94-HB, UL94-V0 is optional)

ISO 9001	
ISO14001	
UL	
CE	
<ul style="list-style-type: none"> ● IEC 60896-21/22 ● JIS C 8704-2 ● GB/T 19638.2 	

DIMENSION(mm/inch)

OUTER DIMENSIONS

TERMINAL TYPE

- **Length**
407±2.0 (16.02±0.08)
- **Width**
173±2.0 (6.81±0.08)
- **Container Height**
210±2.0 (8.27±0.08)
- **Total Height**
239±2.0 (9.41±0.08)

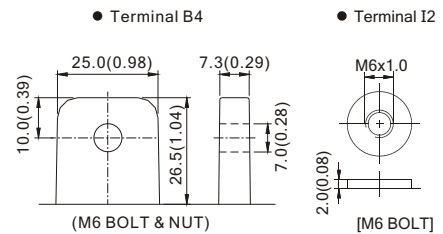
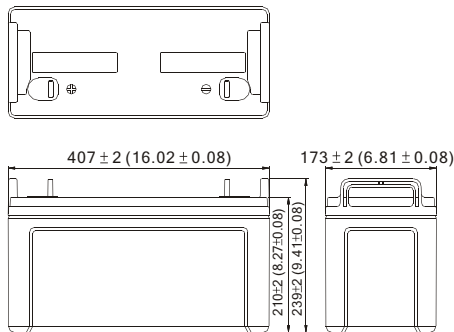

Terminal Hardware Initial Torque: B4/I2(5.5Nm±5%)

Constant power discharge characteristics at 25 °C/77 °F Unit: W

Discharge Time F.V. (V/cell)	15 Min	30 Min	1 Hr	3 Hr	5 Hr	10 Hr	20 Hr
1.80V	2181	1313	759.8	319.8	221.7	123.5	64.6
1.75V	2283	1362	783.5	326.6	225.1	125.4	66.0
1.70V	2352	1393	797.1	330.0	225.9	126.1	66.3
1.65V	2406	1413	807.2	331.7	226.8	126.4	66.5
1.60V	2456	1427	815.7	333.4	226.8	126.4	66.5

Constant current discharge characteristics at 25 °C/77 °F Unit: A

Discharge Time F.V. (V/cell)	15 Min	30 Min	1 Hr	3 Hr	5 Hr	10 Hr	20 Hr
1.80V	190	111	63.9	26.7	18.5	10.29	5.39
1.75V	199	115	65.8	27.2	18.8	10.45	5.50
1.70V	205	118	67.0	27.5	18.8	10.51	5.53
1.65V	209	120	67.8	27.6	18.9	10.53	5.54
1.60V	214	121	68.5	27.8	18.9	10.53	5.54

All data shall be changed without prior notice, BB reserves the right to explain and update the information contained herein.