

# CliQ II Buffer Module

## 24V 20A / DRB-24V020ABA



### Highlights & Features

- Full corrosion resistant Aluminium chassis
- Long minimum buffering time of 250ms @ 24V/20A
- Can connect in parallel to increase buffering time
- Charging time of < 30 seconds
- Designed for Class I Div. 2 Hazardous Locations environments
- IP20 Compliant
- Overvoltage / Overcurrent / Short Circuit Protections
- Meets worldwide safety requirements
- RoHS Directive 2011/65/EU Compliant
- Reliable design, with expected life of 10 years

### Safety Standards



CB Certified for worldwide use

**Model Number:** DRB-24V020ABA  
**Unit Weight:** 0.76kg  
**Dimensions (L x W x D):** 121 x 70 x 120.1 mm

### General Description

Delta CliQ II Buffer Module offers the most widely used output voltage of 24V and one of the longest buffering time of 0.25 sec (min) at 20A in wide input range from 22.8Vdc to 28.8Vdc. The Buffer Module utilizes maintenance-free electrolytic capacitors to store energy, thus eliminates the need of periodic replacement as compared to costlier batteries which also have shorter functional life span. Delta CliQ II Buffer Module comes with comprehensive protection features like overcurrent/overload, overvoltage and short circuit protection. Delta CliQ II series of products is IP20 compliant with full corrosion resistant Aluminium chassis and conformal coating on the PCBAs to provide protection against dust and chemical pollutants.

### Model Information

#### CliQ II Buffer Module

Model Number	Input Voltage Range	Output Voltage	Output Current
DRB-24V020ABA	22.8-28.8Vdc	24Vdc	20A

### Model Numbering

DR	B -	24V	020A	B	A
DIN Rail	Buffer Module	Output Voltage	Output Current	CliQ II Series	Metal Case



# CliQ II Buffer Module

## 24V 20A / DRB-24V020ABA

### Specifications

#### Input Ratings / Characteristics

Nominal Input Voltage	24Vdc
Input Voltage Range	22.8-28.8Vdc
Maximum Input Voltage	35Vdc
Input Current	<b>Charging Mode</b> < 0.6A <b>Discharging Mode</b> 20A Max
Input Power (Standby Mode)	2.5W Average
Maximum Signal Input (Inhibit)	35V / 10mA
Max Inrush Current	< 20A
Charging Time	< 30sec

#### Output Ratings / Characteristics

Nominal Output Voltage	24Vdc typ. (depends on $V_{in}$ )
Output Voltage Adjustment Range	22-28Vdc
	<b>Switch = "Fix 22V"</b> Buffering starts if terminal voltage falls below 22V
	<b>Factory Setting, Switch = "<math>V_{in}-1V</math>"</b> Buffering starts if terminal voltage is decreased by > 1V
Maximum Output Voltage	35Vdc
Output Current	20A Max
Buffering Time	250ms Min @ 24V/20A Load, 5sec Min @ 24V/1A Load (Refer to Fig. 1)
Maximum Signal Output	35V / 10mA
Signals	<b>Inhibit Signal (I)</b> "Low" = Shuts down Buffer Module <b>Ready Signal (R)</b> "High" = Buffer Module is fully charged or in Standby Mode <b>Buffering Signal (B)</b> "High" = Buffer Module is discharging or in Buffering Mode <b>Supply Voltage (+V<sub>S</sub>)</b> Common +V <sub>S</sub> , 35V Max
PARD (20MHz)	< 200mVpp @ 25°C during Buffering Mode
Parallel Connection	Yes
Series Connection	No
Protective Device	Transient Voltage Suppressor (TVS) for signals

Fig. 1 Buffering Time (Typical Values at " $V_{in}-1V$ " Mode)

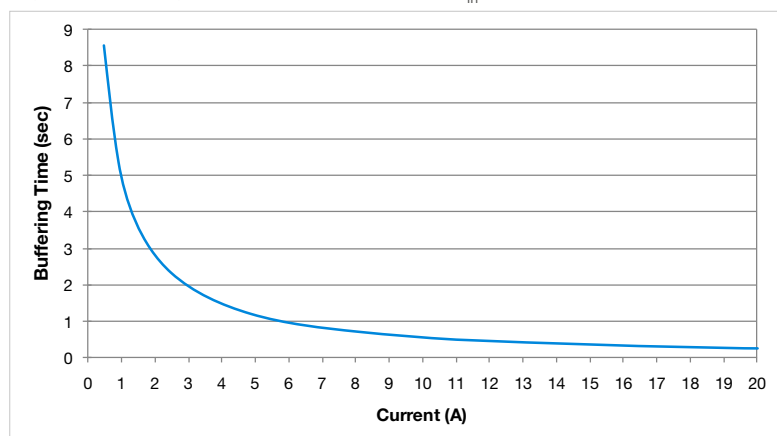

# CliQ II Buffer Module

## 24V 20A / DRB-24V020ABA

### Mechanical

Case Cover	Aluminium	
Dimensions (L x W x D)	121 x 70 x 120.1 mm	
Unit Weight	0.76kg	
LED Indicators	Green LED Off	Unit is discharged or $V_{in} < 22V_{dc}$
	Green LED On	Unit is fully charged
	Green LED Blinking Slowly (1Hz)	Unit is charging
	Green LED Blinking Quickly (10Hz)	Unit is discharging
Cooling System	Convection	
Terminal	Input / Output	M3 x 2 Pins (Rated 300V/30A)
	Signal	M3 x 5 Pins (Rated 300V/30A)
Wire	Input / Output	AWG 12-10
	Signal	AWG 24-10
Mounting Rail	Standard TS35 DIN Rail in accordance with EN60715	

### Environment

Surrounding Air Temperature	Operating	-25°C to +75°C
	Storage	-25°C to +85°C
Power De-rating		> 70°C de-rate power by 5% / °C
Component De-rating		$V_{in} = 22.8-28.8V_{dc}$ , Max load - $T_{ambient} = 50^{\circ}C$ - $T_j < 85\%$ of $T_{jmax}$
Operating Humidity		< 95% RH (Non-Condensing)
Operating Altitude		2,500 Meters
Shock Test (Non-Operating)		IEC60068-2-27, 30G (300m/S <sup>2</sup> ) for a duration of 18ms
Vibration (Non-Operating)		IEC60068-2-6, 10Hz to 500Hz @ 30m/S <sup>2</sup> (3G peak); 60 min per axis for all X, Y, Z direction
Pollution Degree		2

### Protections

Overvoltage	32V ±10%
Overload / Overcurrent	30A Max
Short Circuit	No Damage
Penetration Protection	> 3.5mm (eg. screws, small parts)
Reverse Polarity Protection	Yes
Degree of Protection	IP20
Protection Against Shock	Class I with PE* connection

\*PE: Primary Earth

# CliQ II Buffer Module

## 24V 20A / DRB-24V020ABA

### Reliability Data

MTBF (at $V_{in}$ -1V Mode)	> 800,000 hrs. as per Telcordia SR-332 at Standby Mode (Buffer Module in Ready State)
Expected Cap Life Time	10 years (Standby Mode @ 40°C)

### Safety Standards / Directives

Electronic Equipment in Power Installations	EN50718 / IEC62103
Electrical Safety (Information Technology Equipment)	SIQ to EN60950-1, UL/cUL recognized to UL60950-1, CSA C22.2 No. 60950-1, CB scheme to IEC60950-1
Industrial Control Equipment	UL/cUL listed to UL508 and CSA C22.2 No. 107.1-01, CSA to CSA C22.2 No. 107.1-01 (File No. 181564)
Hazardous Location / ATEX	Pending
⚡ II 3G ATEX 94/9/EC; IECEx Test Report	Certificate No. Pending For IEC60079-0, IEC60079-15
CE	In conformance with EMC Directive 2004/108/EC and Low Voltage Directive 2006/95/EC
Material and Parts	RoHS Directive 2011/65/EU Compliant
Galvanic Isolation	<b>Input &amp; Output to Ground</b> 1.5KVac <b>Signal to Ground</b> 1.5KVac

### EMC

EMC / Emissions	CISPR22, EN55022, EN55011, FCC Title 47: Class B
Component Power Supply for General Use	EN61204-3
Immunity to	EN55024, EN61000-6-2
Electrostatic Discharge	<b>EN61000-4-2</b> Level 4 Criteria A <sup>1)</sup> Air Discharge: 15kV Contact Discharge: 8kV
Radiated Field	<b>EN61000-4-3</b> Level 3 Criteria A <sup>1)</sup> 80MHz–1GHz, 10V/M with 1kHz tone / 80% modulation
Fast Transient / Burst	<b>EN61000-4-4</b> Level 3 Criteria A <sup>1)</sup> 2kV
Surge	<b>IEC61000-4-5</b> Level 3 Criteria A <sup>1)</sup> Common Mode <sup>2)</sup> : 2kV Differential Mode <sup>3)</sup> : 1kV
Conducted	<b>EN61000-4-6</b> Level 3 Criteria A <sup>1)</sup> 150kHz–80MHz, 10Vrms
Power Frequency Magnetic Fields	<b>EN61000-4-8</b> Level 3 Criteria A <sup>1)</sup> 10A/Meter
Voltage Dips	<b>EN61000-4-11</b> Level 3 Criteria A <sup>1)</sup> Additional 100% dip; 1 cycle (20ms); No Damage
Low Energy Pulse Test (Ring Wave)	<b>IEC61000-4-12</b> Level 3 Criteria A <sup>1)</sup> Common Mode <sup>2)</sup> : 2kV Differential Mode <sup>3)</sup> : 1kV

Note: Product intended to be used as Apparatus with AC-DC Power Supply, EMC compliance to be verified in correspondence to the connected units.

1) Criteria A: Normal performance within the specification limits

2) Asymmetrical: Common mode (Line to earth)

3) Symmetrical: Differential mode (Line to line)

# CliQ II Buffer Module

## 24V 20A / DRB-24V020ABA

### Block Diagram

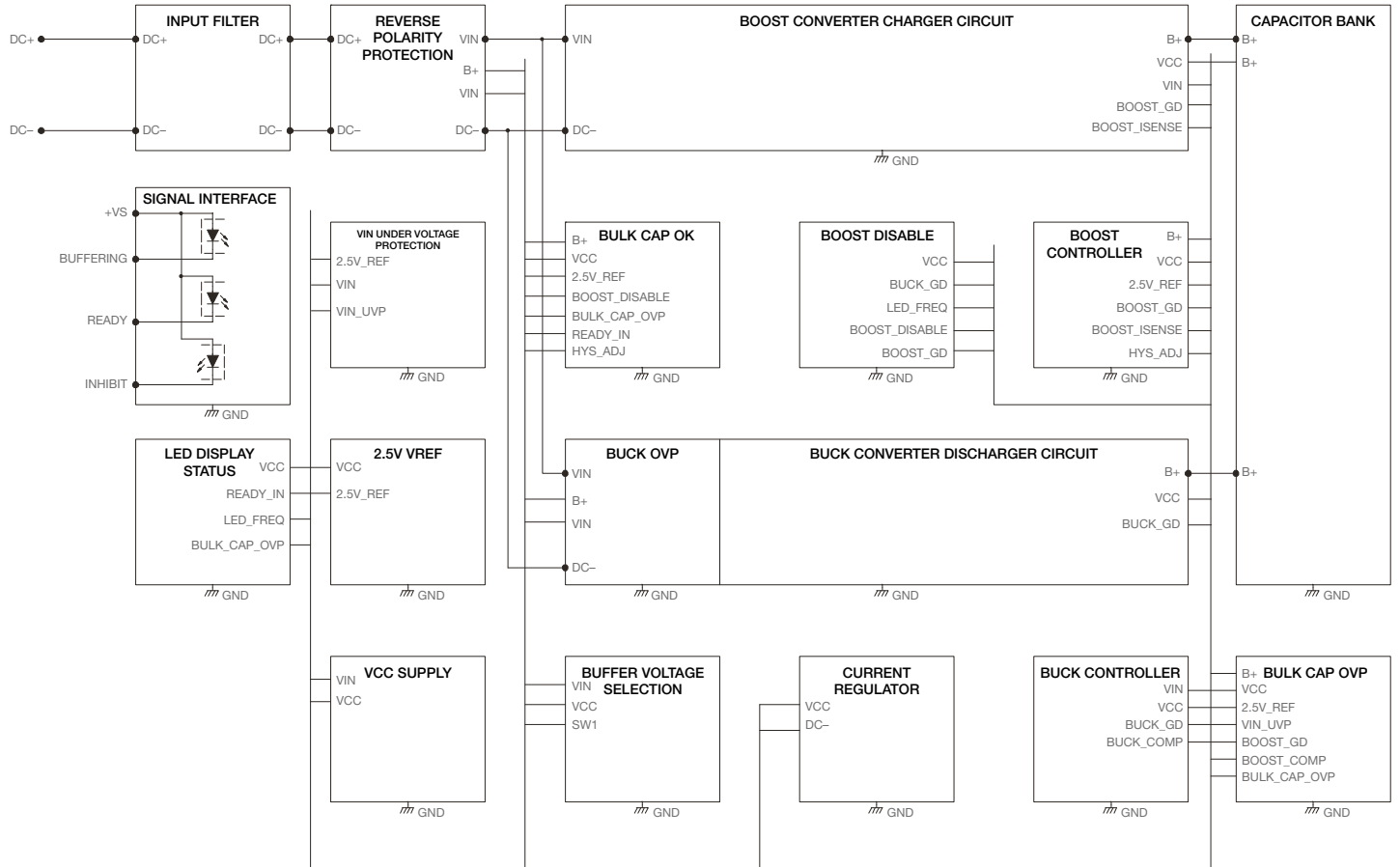

### Device Description

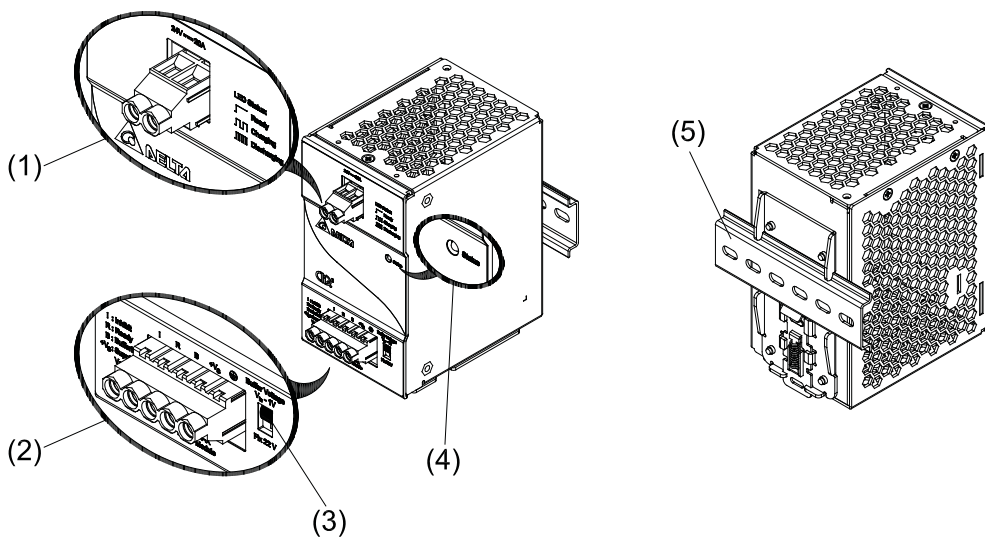

- 1) Input / Output terminal block connector
- 2) Signal terminal block connector
- 3) Select switch (operation mode)

- 4) LED display status
- 5) Universal mounting rail system

# CliQ II Buffer Module

## 24V 20A / DRB-24V020ABA

### Dimensions

L x W x D: 121 x 70 x 120.1 mm

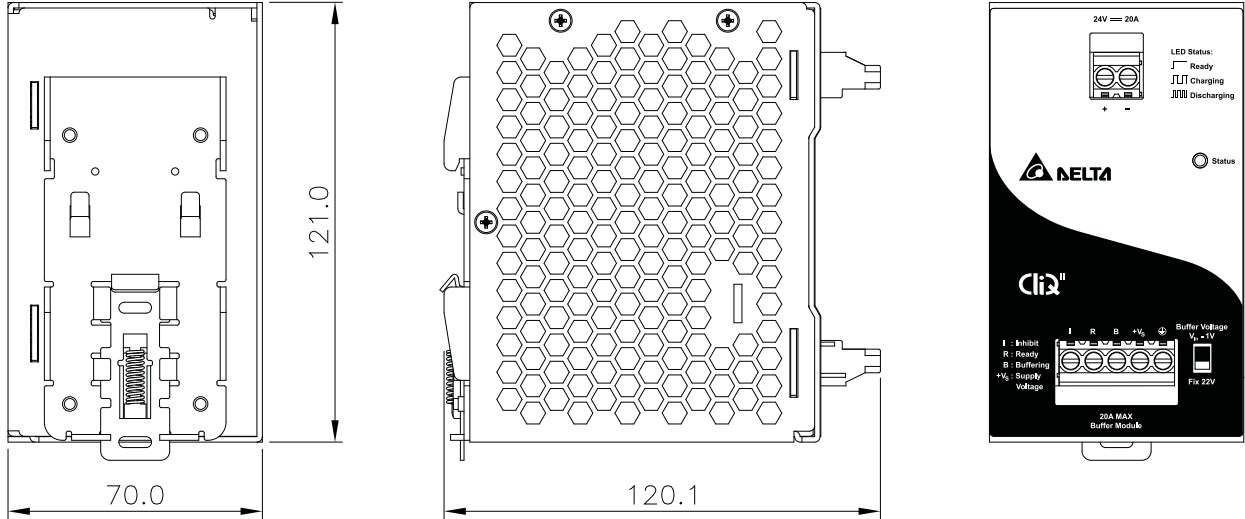

### Engineering Data

#### De-rating

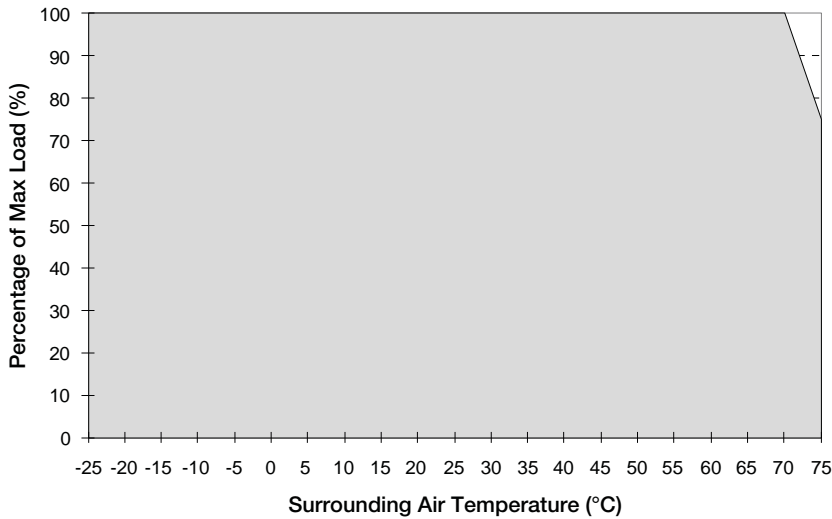

Fig. 2 De-rating for Vertical Mounting Orientation  
 > 70°C de-rate power by 5% / °C

#### Notes

1. Components may degrade, or be damaged, when the buffer module is continuously used outside the shaded region, refer to the graph shown in Fig. 2.
2. In order for the device to function in the manner intended, it is also necessary to keep a safety distance of 20mm with adjacent units while the device is in operation.
3. Depending on the surrounding air temperature and output load delivered by the buffer module, the device housing can be very hot!
4. If the device has to be mounted in any other orientation, please do not hesitate to contact [info@deltapsu.com](mailto:info@deltapsu.com) for more details.

# CliQ II Buffer Module

## 24V 20A / DRB-24V020ABA

### Assembly & Installation

The buffer module can be mounted on 35mm DIN rails in accordance with EN60715. The device should be installed with input / output terminal block at the top.

Each device is delivered ready to install.

#### Mounting

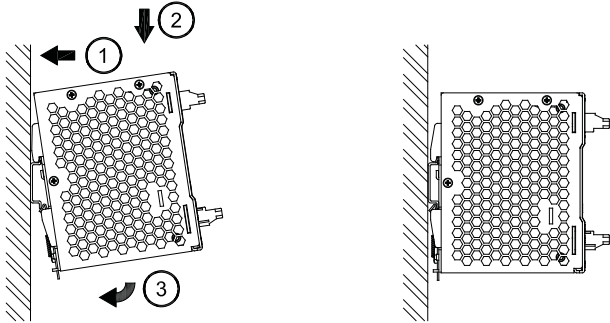

Fig. 3.1 Mounting

Snap on the DIN rail as shown in Fig. 3.1:

1. Tilt the unit upwards and insert it onto the DIN rail.
2. Push downwards until stopped.
3. Press against the bottom front side for locking.
4. Shake the unit slightly to ensure that it is secured.

#### Dismounting

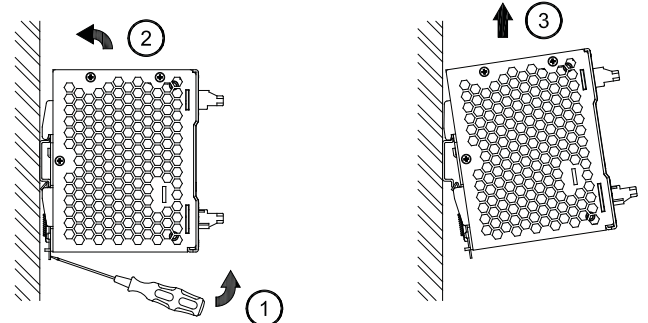
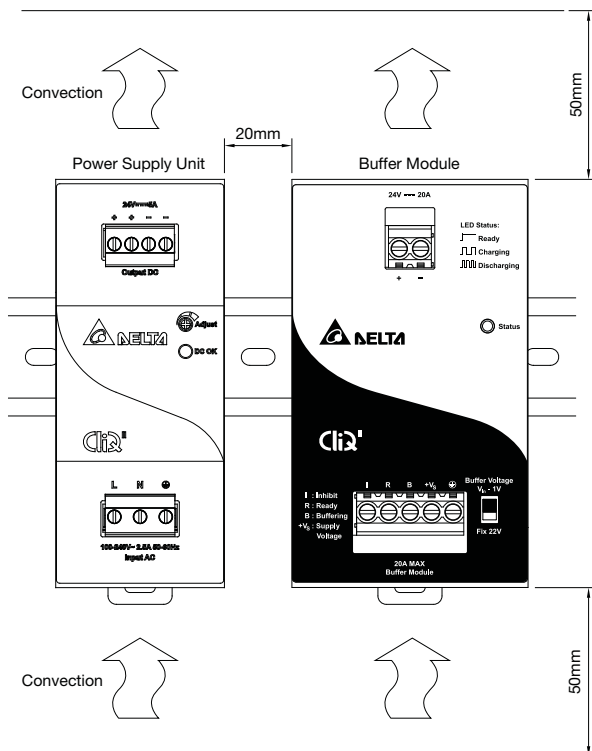

Fig. 3.2 Dismounting

To uninstall, pull or slide down the latch with screw driver as shown in Fig 3.2. Then slide the unit in the opposite direction, release the latch and pull out the unit from the rail.

### Safety Instructions



- ALWAYS switch mains of input power OFF before connecting or disconnecting the input voltage to the unit. If mains are not turned OFF, there is risk of explosion / severe damage.
- **To guarantee sufficient convection cooling, keep a distance of 50mm above and below the device as well as a lateral distance of 20mm to other units.**
- Note that the enclosure of the device can become very hot depending on the surrounding air temperature and load of the unit. Risk of burns!
- Only plug in and unplug connectors when power is turned off!
- DO NOT insert any objects into the unit.
- Hazardous voltages may be present for up to 5 minutes after the input mains voltage is disconnected. Do not touch the unit during this time.
- The unit should be installed in minimum IP54 rated enclosure.
- The units must be installed in a cabinet or room (condensation free environment and indoor location) that is relatively free of conductive contaminants.

# CliQ II Buffer Module

## 24V 20A / DRB-24V020ABA

### Functions

#### Buffering, Ready, and Inhibit Signal

<b>Buffering Signal (B)</b>	“High” = Buffer Module is discharging or in Buffering Mode
Maximum Signal Voltage	35Vdc
Maximum Signal Current	10mA
Isolation (Signal Port to Power Port)	1.5KVdc
<b>Ready Signal (R)</b>	“High” = Buffer Module is fully charged or in Standby Mode
Maximum Signal Voltage	35Vdc
Maximum Signal Current	10mA
Isolation (Signal Port to Power Port)	1.5KVdc
<b>Inhibit Signal (I)</b>	“Low” = Shuts down Buffer Module
Maximum Signal Voltage	35Vdc
Maximum Signal Current	10mA
Shut-down Threshold	6Vdc Min / 10Vdc Max
Isolation (Signal Port to Power Port)	1.5KVdc

### Operating Diagram

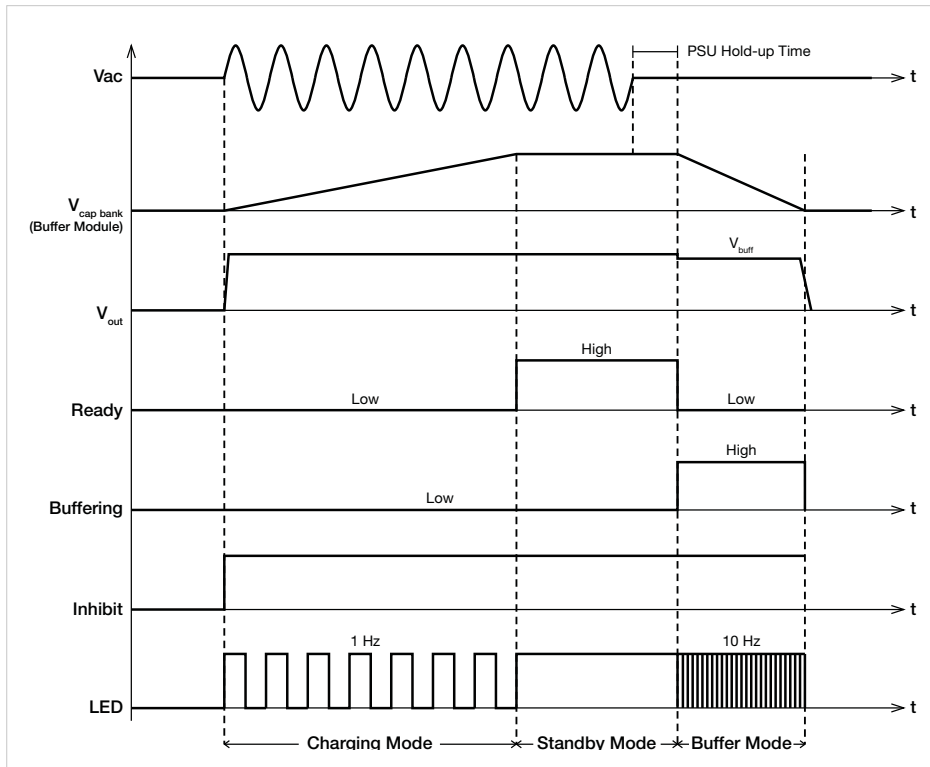

### Wiring Schematics

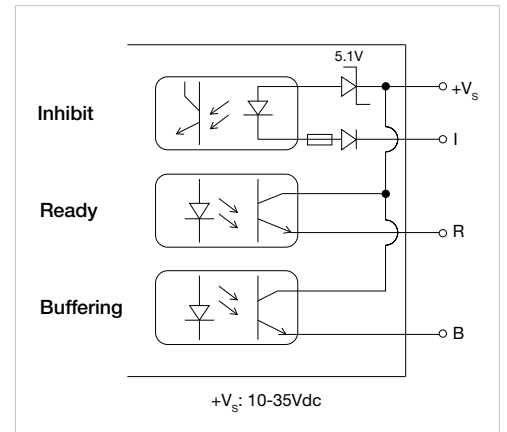

Typical Application Notes can be found on Page 9.



# CliQ II Buffer Module

## 24V 20A / DRB-24V020ABA

### Typical Application Notes

Fig. 4.1 General Connection / Wiring Diagram

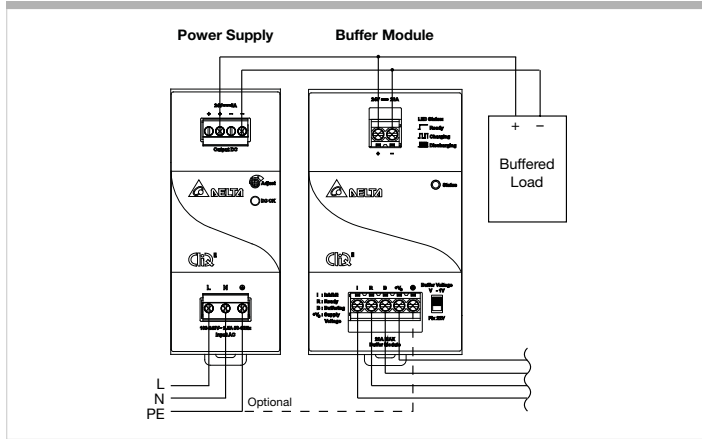

Fig. 4.2 Paralleling of Buffer Units

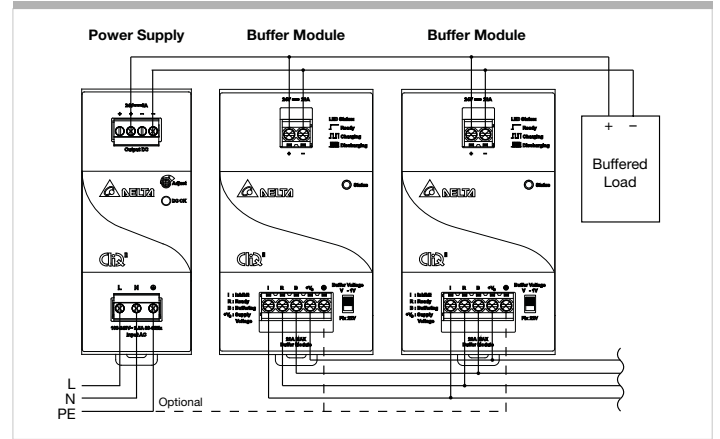

Fig. 4.3 Decoupling of Buffered Branches

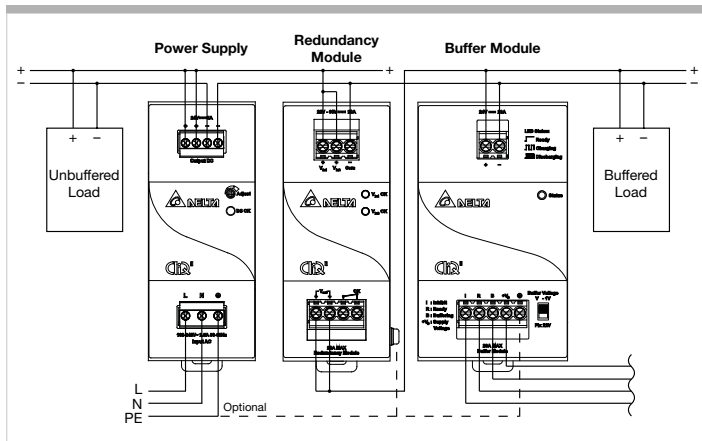

Fig. 4.4 General Signals Wiring

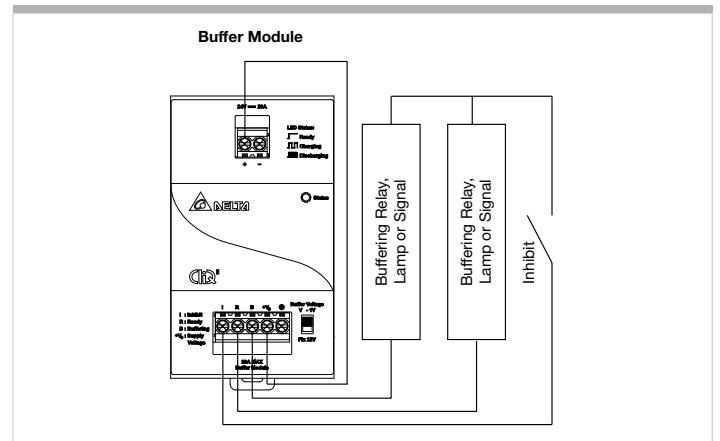

Fig. 4.5 Signals Supplied from an External Voltage

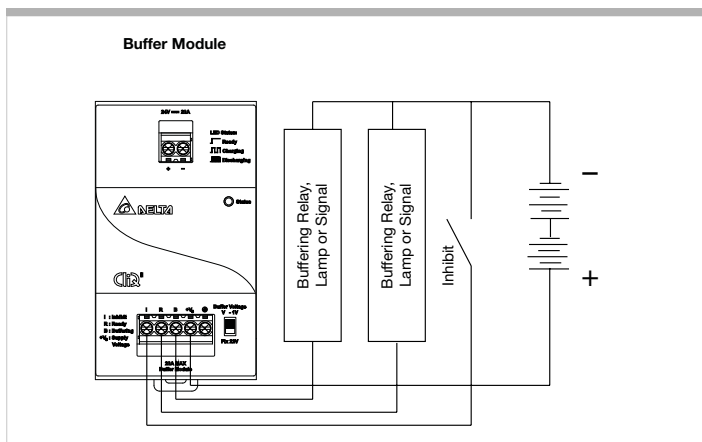
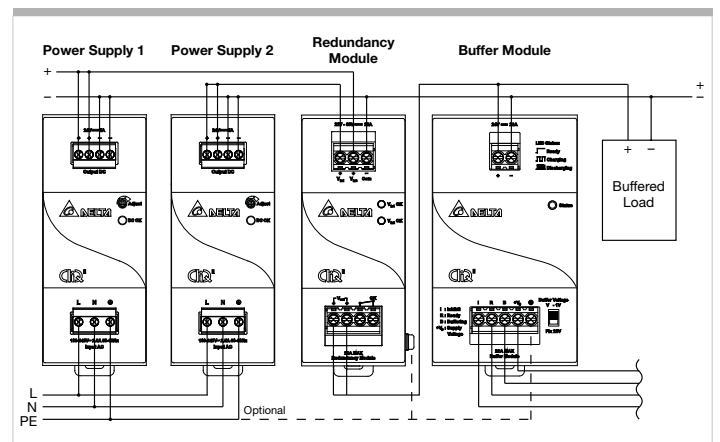

Fig. 4.6 Connection Diagram with Redundant Operation



# CliQ II Buffer Module

## 24V 20A / DRB-24V020ABA

### Connectable Power Supplies

The buffer module is recommended to be connected with the following power supplies:

#### CliQ Series

- DRP024V060W1AZ
- DRP024V060W1AA
- DRP024V120W1AA
- DRP024V240W1AA
- DRP024V480W1AA
- DRP024V060W3AA
- DRP024V120W3AA
- DRP024V240W3AA
- DRP024V480W3AA

#### CliQ II Series

- DRP024V060W1BA
- DRP024V120W1BA
- DRP024V240W1BA
- DRP024V480W1BA

More new products can be found at [www.DeltaPSU.com](http://www.DeltaPSU.com).

### Inrush Current

Inrush current is the peak, instantaneous, input current measured and occurs when input voltage is first applied. For DC input voltage the maximum peak value of inrush will occur during the first applied DC voltage.

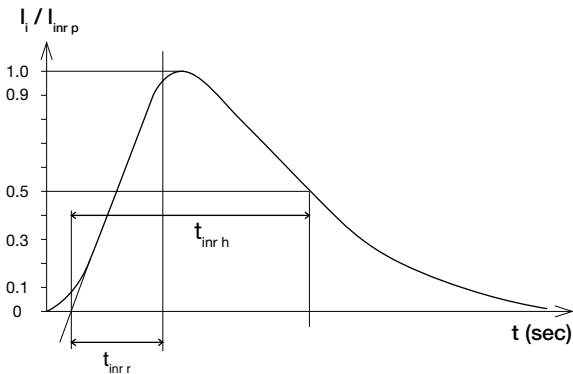

### Overvoltage Protection

The buffer module's overvoltage protection will be activated when DC input to the module exceeds the maximum specified input voltage. The overvoltage limits are same as power supply limits,  $32V \pm 10\%$ . Buffer module will shut down and latch during overvoltage mode, and will return to normal operation upon removal of fault and power supply input is recycled (ON/OFF) or input to buffer module is recycled.

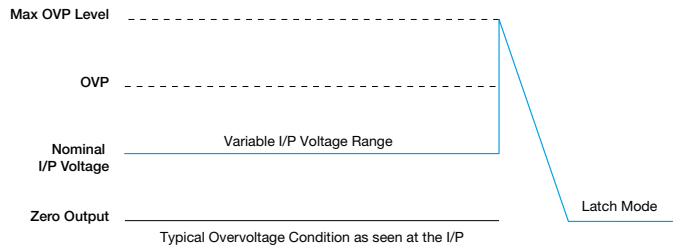

### Overload & Overcurrent Protections

When the output current exceeds 120% of  $I_o$  (Max load) buffer module will shut down and latch. Normal operation of buffer module can be resumed upon removal of fault and power supply input is recycled (ON/OFF) or input to buffer module is recycled.

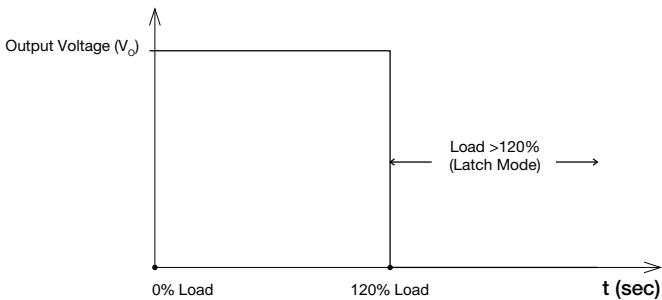

### Short Circuit Protection

Buffer module is protected by short circuit during buffering mode, in the event of short circuit the module will shut down and latch. Operation can be resumed upon removal of fault and power supply input is recycled (ON/OFF) or input to buffer module is recycled.

# CliQ II Buffer Module

## 24V 20A / DRB-24V020ABA

### Others

#### Delta RoHS Compliant



##### Restriction of the usage of hazardous substances

The European directive 2011/65/EC limits the maximum impurity level of homogeneous materials such as lead, mercury, cadmium, chrome, polybrominated flame retardants PBB and PBDE for the use in electrical and electronic equipment. RoHS is the abbreviation for "Restriction of the use of certain hazardous substances in electrical and electronic equipment".

This product conforms to this standard.

#### Conformal Coating

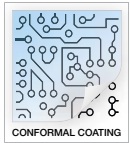

##### The Protective Coating Technology

Delta Electronics Group has designed the perfect dipping technique which penetrates everywhere including under device, and prevents leakage. The conformal coating dipping can be applied to PCBs or circuit board. The coating preserves the performance of precision electronic primarily by preventing ionizable contaminants such as salt from reaching circuit nodes, where the material slumps around sharp edges. This can be a problem especially in highly conversing atmosphere.