

REVISION RECORD		
REV	DESCRIPTION	DRFT

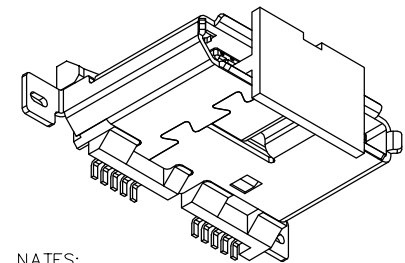

NOTES:

- MACHANICAL CHARACTERISTICS:
 MATING FORCE: 1.30±0.30kgf.
 UNMATING FORCE: 1.30±0.30kgf.
 DURABILITY: 10000 CYCLES
- ELECTRICAL CHARACTERISTICS:
 CURRENT RATING: 1.5A
 CONTACT RESISTANCE: 30mΩ Max.
 DIELECTRICAL WITHSTANDING: 100V AC/1min.
 INSULATION RESISTANCE: 100MΩ Min.
- MATERIAL:
 PLASTIC: LCP WITH 30% GF, UL 94V-0, BLACK.
 TERMINAL BRASS, 0.15 THICKNESS.
 TERMINAL PLATING:
 50u" MIN NICKEL UNDERPLATING OVER ALL,
 HALF HARD GOLD 5u", MATTE TIN 100u"
 SHIELD: STEEL 0.3 THICKNESS.
 SHIELD PLATING:
 50u" MIN CU UNDERPLATING OVER ALL,
 50u" MIN NICKEL PLATING OVER ALL,
 OPERATION TEMPERATURE: +20°C to +80°C

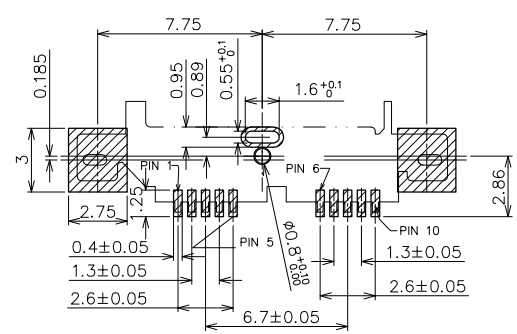
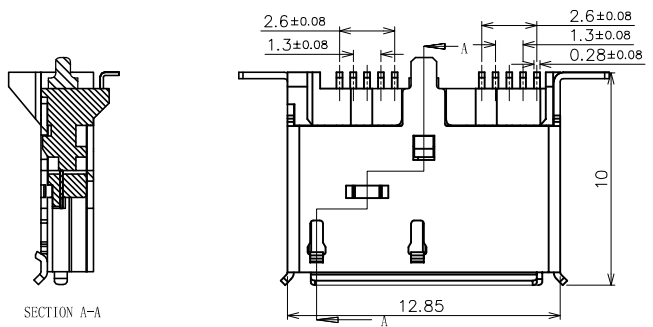
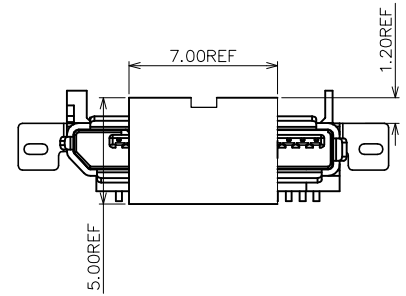
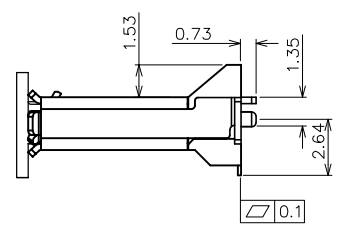
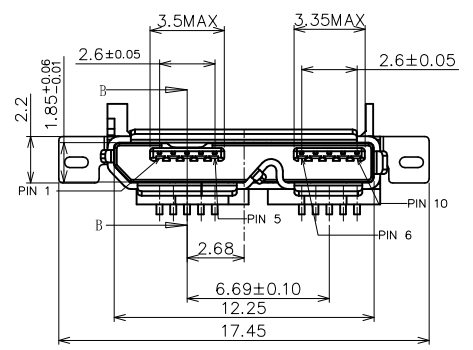
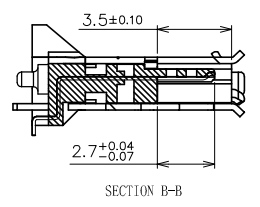

DETACHED LISTS	MM (INCH)	DFTD Roy	DATE 11/20/2012	Pulse Electronics	RoHS Compliant	
	TOLERANCES EXCEPT AS NOTED	CHKD	DATE			
	MM	±	APPVL	DATE	TITLE USB 3.0 MICRO BF SMD TYPE	
	.0 ± 0.35	±	MATERIAL			
	.0 ± 0.25	±	ANGLES: X*±1° X.X*±0.5*	QTY	DRAWING NO. E8110-032-01	SIZE A3
.00 ± 0.15	±	THIRD ANGLE PROJECTION	FINISH	/PART NO. E8110-032-01	DO NOT SCALE DRAWING	SHEET 1 OF 1
.000 ± 0.05	±		SCALE: 1:1			