

A-A
SCALE 2:1

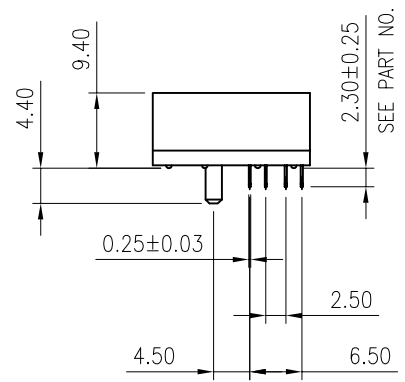

ACCEPTED 1.57 PCB

REVISION RECORD		
REV	DESCRIPTION	DRFT

DIMENSIONS				
POSITION	N	B ±0.15	C ±0.20	D ±0.25
36	6	7.75	9.00	25.00
64	20	21.75	23.00	39.00
98	37	38.75	40.00	56.00
164	70	71.75	73.00	89.00

NOTES:

1. MATERIAL:
 - 1.1 HOUSING: HIGH TEMPERATURE THERMOPLASTIC, COLOR: BLACK
 - 1.2 CONTACTS: COPPER ALLOY, T=0.25mm
2. FINISH:
 - 2.1 CONTACT: SELECTIVE GOLD PLATING ON CONTACT AREA, 100µ" MIN. MATTE TIN PLATING ON SOLDER TAILS, 50µ" MIN. NICKEL UNDERPLATING OVERALL.

DETACHED LISTS	MM (INCH)		DFTO Ella Xu	DATE 11/14/12	Pulse Electronics	RoHS Compliant	
	TOLERANCES EXCEPT AS NOTED		CHKD	DATE			
	MM	±	APPL	DATE	TITLE PCI EXPRESS CARD EDGE, 1.0mm PITCH, R/A TYPE		
	.0 ± 0.40	±	MATERIAL :				
	.0 ± 0.30	±	QTY :		DRAWING NO. E9003-XXX-XX		SIZE A3
.00 ± 0.20	±	FINISH :		/PART NO. E9003-XXX-XX		DO NOT SCALE DRAWING	
.000 ± 0.10	±	SCALE : 1:1		DO NOT SCALE DRAWING		SHEET 1 OF 2	

REVISION RECORD		
REV	DESCRIPTION	DRFT

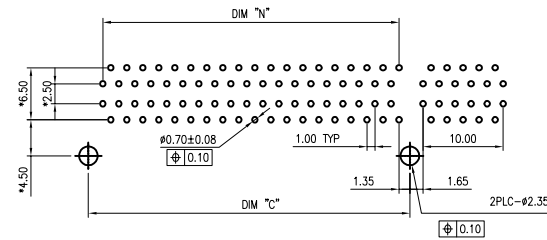
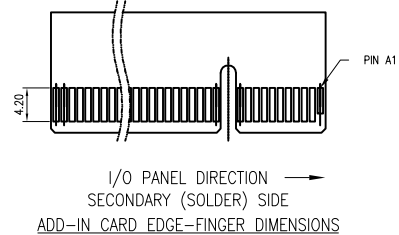
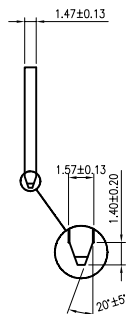
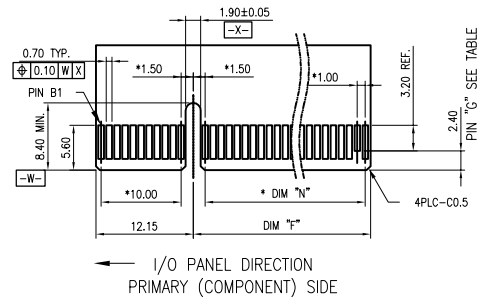

RECOMMENDED PCB LAYOUT
TOLERANCE: ±0.05

	DIMENSIONS			
POSITION	N	C	F ±0.20	G
36	6	9.00	8.15	B PIN#17
64	20	23.00	22.15	B PIN#31
98	37	40.00	39.15	B PIN#48
164	70	73.00	72.15	B PIN#81

PRAT NUMBER	DESCRIPTION	PLATING Au	No.of Pins	PACKING
E9003-001-02	PCI Express Connector, Right Angle, THT,	15u"	36pin	TRAY
E9003-002-02		15u"	64pin	
E9003-003-02		15u"	98pin	
E9003-004-02		15u"	164pin	

DETACHED LISTS	MM (INCH)		DFTO Ella Xu	DATE 11/14/12	RoHS Compliant	
	TOLERANCES EXCEPT AS NOTED		CHKD	DATE		
	MM		APPVL	DATE	TITLE PCI EXPRESS CARD EDGE, 1.0mm PITCH, R/A TYPE	
	. ± 0.40		MATERIAL :			
	.0 ± 0.30	±	QT'Y :		DRAWING NO. E9003-XXX-XX	SIZE A3
.00 ± 0.20	±	FINISH :		/PART NO. E9003-XXX-XX	DO NOT SCALE DRAWING	
.000 ± 0.10	±	THIRD ANGLE PROJECTION		SCALE : 1:1	SHEET 2 OF 2	