

REVISION RECORD				
REV	ECO	DESCRIPTION	DRFT	CHKD
△		Drawing Modification	JAMMYN 1/19/06	

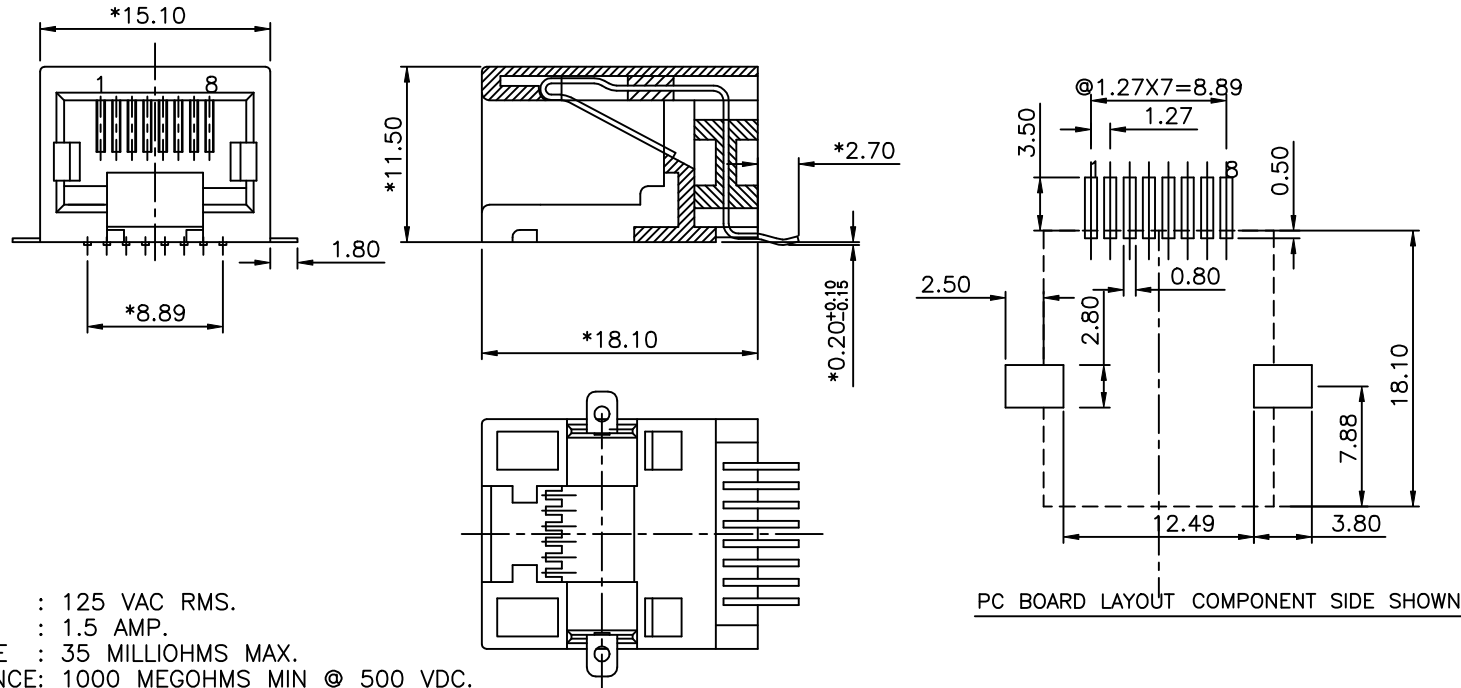

**NOTES:**

**ELECTRICAL:**

- VOLTAGE RATING : 125 VAC RMS.
- CURRENT RATING : 1.5 AMP.
- CONTACT RESISTANCE : 35 MILLIOHMS MAX.
- INSULATION RESISTANCE: 1000 MEGOHMS MIN @ 500 VDC.
- DIELECTRIC STRENGTH : 1000 VAC RMS 60Hz, 1MIN.

**MECHANICAL:**

- HOUSING MATERIAL : FR52 UL94V-0 COLOR:BK
- CONTACT MATERIAL : PHOSPHOR BRONZE t=0.35mm.
- PLATING : 1: CONTACT AREA- SELECTIVE GOLD PLATING.  
2: TAILS- PLATED TIN OVER NICKEL.
- OPERATING LIFE : 750 CYCLES MIN.
- PCB RETENTION PRE-SOLDER : 1 LB MIN.
- PCB RETENTION POST-SOLDER: 10 LBS MIN.

**ENVIRONMENTAL:**

- STORAGE : -40°C TO +85°C.
- OPERATION: -40°C TO +85°C.
- IR REFLOW SOLDERING TEMPERATURE: 255°C TO 265°C (5-10 SECONDS).

MATES WITH MODULAR PLUG CONFORMING TO  
FCC PART 68, SUBPART F.  
ROHS PART NUMBER: E5388-EH05YX-L

1-3U"      2-6U"  
3-15U"    4-30U"  
5-50U"

△	Cavities/reel	Pieces/reel	Pieces/carton
	150	130	1300

← MM (INCH) →		DFTO SAMMY	DATE 04/16/05	FULL RISE ELECTRONIC CO., LTD	
TOLERANCES EXCEPT AS NOTED		CHKD:JAMMY	DATE 2006/1/21	TITLE SIDE ENTRY 8P(SMT)	
		MFO	DATE		
MM	±	APPV:LUSHENG	DATE 2006/1/21	DRAWING NO. GE533049-LA      SIZE A3      REV 1	
.0 ±0.20	±				
.00 ±0.15	±			/PART NO. SEE NOTE	
.000 ±0.075	±				
ANGLES ±		MATERIAL :		DO NOT SCALE DRAWING      SHEET X OF Y	
THIRD ANGLE PROJECTION		MATERIAL :			
		QT'Y :			
		FINISH :			
		SCALE : 3:1			