

REVISION RECORD				
REV	ECO	DESCRIPTION	DRFT	CHKD
△		DRAWING CHANGE	SKYCHEN 07/28/06	

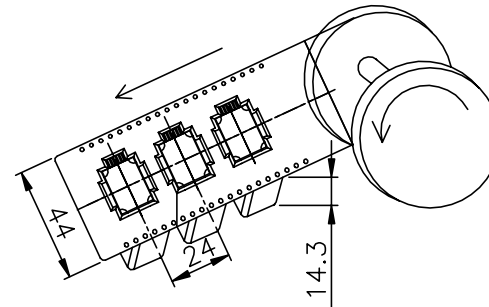
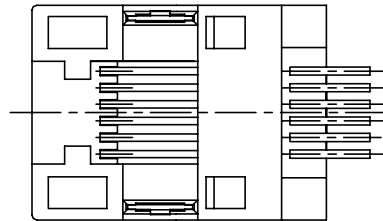
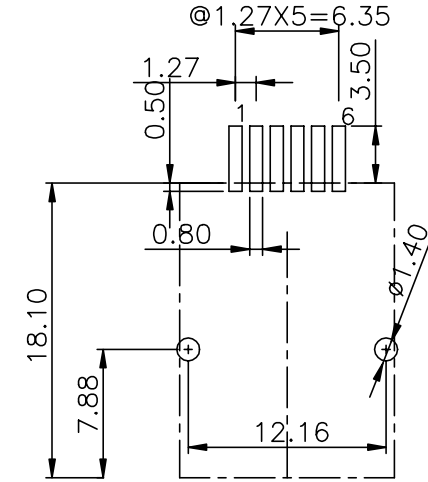
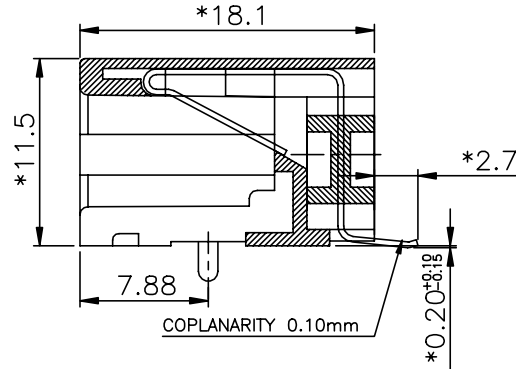
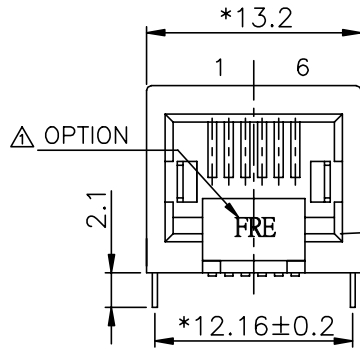

NOTES:

ELECTRICAL:

- VOLTAGE RATING : 125 VAC RMS.
- CURRENT RATING : 1.5 AMP.
- CONTACT RESISTANCE : 35 MILLIOHMS MAX.
- INSULATION RESISTANCE: 1000 MEGOHMS MIN @ 500 VDC.
- DIELECTRIC STRENGTH : 1000 VAC RMS 60Hz, 1MIN.

MECHANICAL:

- HOUSING MATERIAL : NYLON+GF30% UL94V-0. COLOR:BLACK
- CONTACT MATERIAL : PHOSPHOR BRONZE t=0.35mm.
- PLATING : GOLD PLATING OVER NICKEL.
- OPERATING LIFE : 750 CYCLES MIN.
- PCB RETENTION POST-SOLDER: 10 LBS MIN.

ENVIRONMENTAL:

- STORAGE : -40°C TO +85°C.
- OPERATION: -40°C TO +85°C.
- IR REFLOW PEAK SOLDERING TEMPERATURE: 255°C TO 265°C 5~10 SECONDS.
- RoHS COMPLIANT.

MATES WITH MODULAR PLUG CONFORMING TO FCC PART 68, SUBPART F.

△ RoHS PART NUMBER: E536X-FX05YX-L

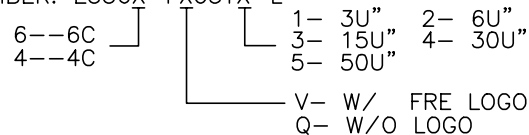

MM (INCH)		DFTO ANKUE	DATE 04/21/05
TOLERANCES EXCEPT AS NOTED		CHKDANKUE	DATE 2006/7/28
		MFO	DATE
		APPVLLUSHENG	DATE 2006/7/28
MM		MATERIAL :	
.0 ± 0.2	±	QT'Y :	
.00 ± 0.15	±	FINISH :	
.000 ± 0.075	±	SCALE : 3:1	
ANGLES ± 0.5		THIRD ANGLE PROJECTION	

	RoHS Compliant
FULL RISE ELECTRONIC CO., LTD	
TITLE SIDE ENTRY PCB JACK(SMT) 6P	
DRAWING NO. GE533069-LA	SIZE A3
/PART NO. SEE NOTE	REV 1
DO NOT SCALE DRAWING	SHEET 1 OF 1