

REVISION RECORD				
REV	ECO	DESCRIPTION	DRFT	CHKD
△		NOTES MODIFY	Among 11/08/04	

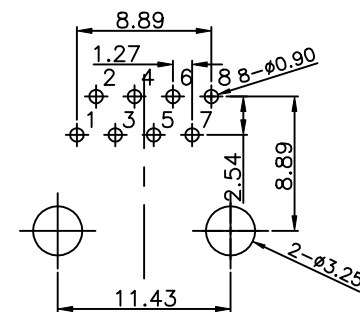
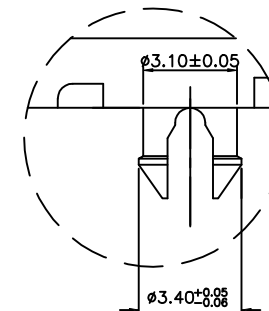
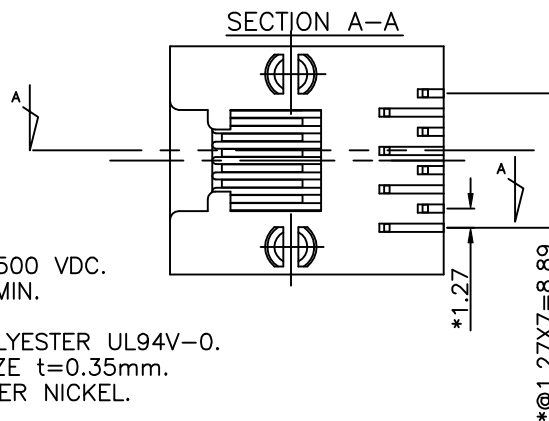
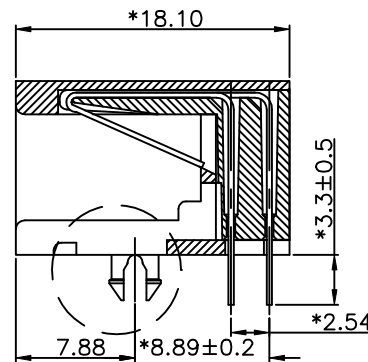
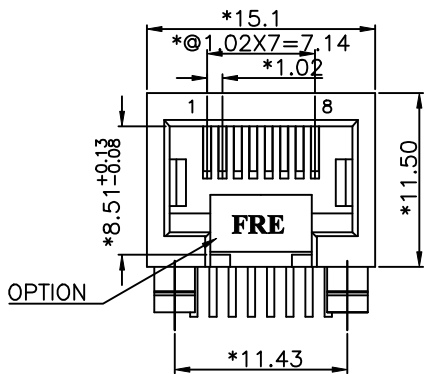

PCB T=1.60mm
PC BOARD LAYOUT COMPONENT SIDE SHOWN

NOTES:

ELECTRICAL:

- VOLTAGE RATING : 125 VAC RMS.
- CURRENT RATING : 1.5 AMP.
- CONTACT RESISTANCE : 35 MILLIOHMS MAX.
- INSULATION RESISTANCE: 1000 MEGOHMS MIN @ 500 VDC.
- DIELECTRIC STRENGTH : 1000 VAC RMS 60Hz, 1MIN.

MECHANICAL:

- HOUSING MATERIAL : GLASS FILLED POLYESTER UL94V-0.
- CONTACT MATERIAL : PHOSPHOR BRONZE t=0.35mm.
- △ PLATING : GOLD PLATING OVER NICKEL.
- OPERATING LIFE : 750 CYCLES MIN.
- PCB RETENTION PRE-SOLDER : 1 LB MIN.
- PCB RETENTION POST-SOLDER: 10 LBS MIN.

ENVIRONMENTAL:

- STORAGE : -40°C TO +85°C.
 - OPERATION: -40°C TO +85°C.
- MATES WITH MODULAR PLUG CONFORMING TO FCC PART 68, SUBPART F.

CUL FILE NO. E163191

PART NUMBER: E538X-E002XX-L

NO OF CONTACT:	1- 3u"	2- 6u"
2- 2C	3-15u"	4-30u"
4- 4C	5-50u"	6-Pd 20u"
6- 6C	1-W/FRE LOGO	
8- 8C	R-W/O LOGO	

MM (INCH)		DFTO SAMMY	DATE 06/22/04	FULL RISE ELECTRONIC CO., LTD	
TOLERANCES EXCEPT AS NOTED		CHKD SAMMY	DATE2004/11/16	TITLE 11.5 SIDE ENTRY 8P FCC DEEP TYPE(LEAD_FREE)	
		MFO	DATE		
MM		APPV LUSHENG	DATE2004/11/17	DRAWING NO. GE533096 /PART NO. SEE NOTE	
.0 ±0.20	±	MATERIAL :			
.00 ±0.15	±	QT'Y :		SIZE REV	
.000 ±0.075	±	FINISH :		A3 1	
ANGLES ±		SCALE :		DO NOT SCALE DRAWING	
THIRD ANGLE PROJECTION				SHEET X OF Y	