

A1RFRD10

REVISION RECORD				
REV	ECO	DESCRIPTION	DRFT	CHKD

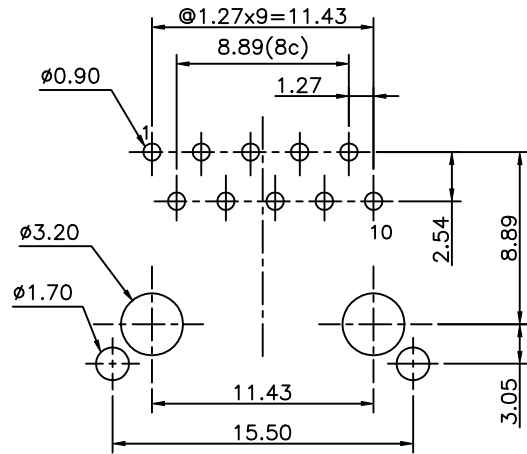
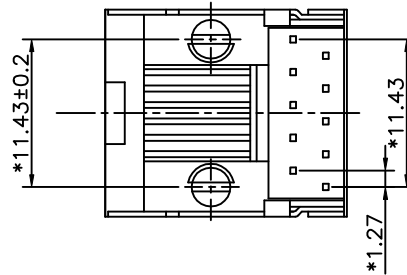
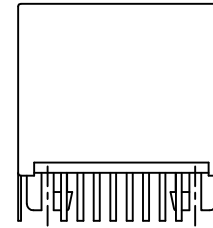
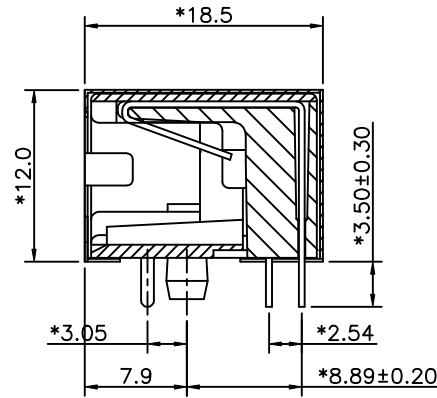
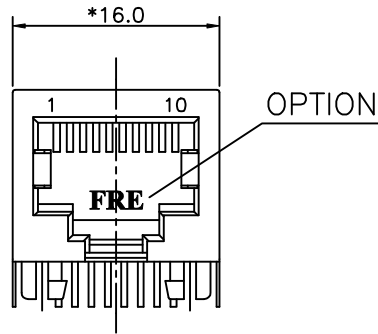

PC Board Layout T=1.60mm
Component Side Shown

NOTES:

ELECTRICAL:

- VOLTAGE RATING : 125 VAC RMS.
- CURRENT RATING : 1.5 AMP.
- CONTACT RESISTANCE : 45 MILLIOHMS MAX.
- INSULATION RESISTANCE: 1000 MEGOHMS MIN @ 500 VDC.
- DIELECTRIC STRENGTH : 1000 VAC RMS 60Hz, 1MIN.

MECHANICAL:

- HOUSING MATERIAL : PBT+30%.G.F UL94V-0.
- CONTACT MATERIAL : PHOSPHOR BRONZE t=0.35mm.
- PLATING : GOLD PLATING OVER NICKEL.
- OPERATING LIFE : 750 CYCLES MIN.
- PCB RETENTION PRE-SOLDER : 1 LB MIN.
- PCB RETENTION POST-SOLDER: 10 LBS MIN.

ENVIRONMENTAL:

- STORAGE : -40°C TO +85°C.
 - OPERATION: -40°C TO +85°C.
 - WAVE SOLDERING TEMPERATURE: 230°C~250°C(3~5 SECONDS)
- MATES WITH MODULAR PLUG CONFORMING TO
FCC PART 68, SUBPART F.
CUL FILE NO. E163191

ROHS PART NUMBER: E560X-XE008X-L

NO. OF CONTACT	1- 3u"	2- 6u"
8- 8 CONTACTS	3-15u"	4-30u"
1-10 CONTACTS	5-50u"	6-Pd 20u"

- 0- TIN W/ FRE LOGO
- 3- NICKEL W/O FRE LOGO
- 4- NICKEL W/ FRE LOGO
- 6- 3u" GOLD PLATING

← MM (INCH) →		DFTO JAMY	DATE 06/18/05	FULL RISE ELECTRONIC CO., LTD	
TOLERANCES EXCEPT AS NOTED		CHKD SAMMY	DATE 2005/06/20	TITLE W/SHIELDED	
		MFO	DATE	RJ45 SIDE ENTRY PCB JACK 10P	
		APPV LUSHENG	DATE 2005/06/20	DRAWING NO. GE563A62-LC	
		MATERIAL :		SIZE A3	REV 0
ANGLES ± 0.5		QT'Y :		/PART NO. SEE NOTE	
THIRD ANGLE PROJECTION		FINISH :		DO NOT SCALE DRAWING	
		SCALE : 2.5 : 1		SHEET 1 OF 1	

8

7

6

5

4

3

2

1

A

B

C

D

E

F

G

H