

REVISION RECORD				
REV	ECO	DESCRIPTION	DRFT	CHKD

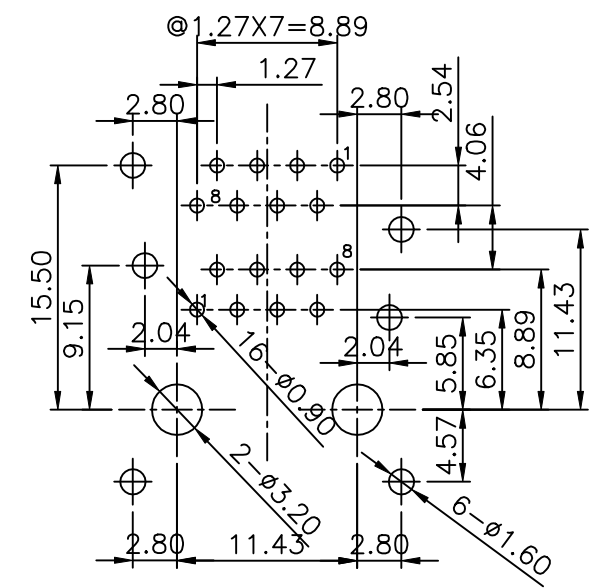
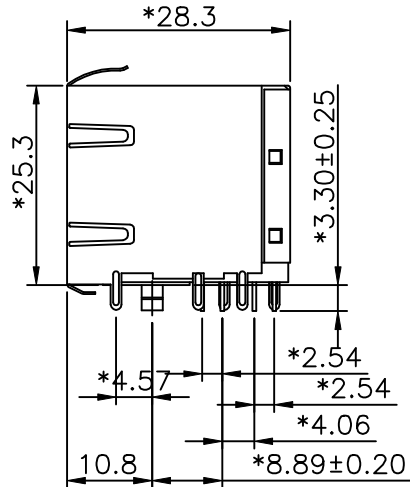
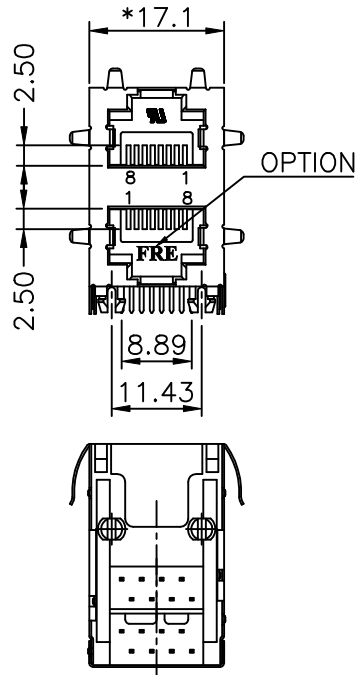

NOTES:

ELECTRICAL:

1. VOLTAGE RATING : 125 VAC RMS.
2. CURRENT RATING : 1.5 AMP.
3. CONTACT RESISTANCE : 50 MILLIOHMS MAX.
4. INSULATION RESISTANCE: 1000 MEGOHMS MIN @ 500 VDC.
5. DIELECTRIC STRENGTH : 1000 VAC RMS 60Hz, 1MIN.

MECHANICAL:

1. HOUSING MATERIAL : PBT+30%.G.F UL94V-0.
2. HOUSING COLOUR : BLACK.
3. CONTACT MATERIAL : PHOSPHOR BRONZE t=0.35mm.
4. PLATING : GOLD PLATING OVER NICKEL.
5. OPERATING LIFE : 750 CYCLES MIN.
6. PCB RETENTION PRE-SOLDER : 1 LB MIN.
7. PCB RETENTION POST-SOLDER: 10 LBS MIN.

ENVIRONMENTAL:

1. STORAGE : -40°C TO +85°C.
2. OPERATION: -0°C TO +70°C.
3. WAVE SOLDERING TEMPERATURE: 230°C ~250°C (5~10 SECONDS).

MATES WITH MODULAR PLUG CONFORMING TO

FCC PART 68, SUBPART F.

CUL FILE NO. E163191

ROHS PART NUMBER: E5908-XX014X-L

- | | |
|---------------------------|--|
| 1-W/O TABS | 1- 3u" 2- 6u" 3-15u" |
| 2-W/ TOP TABS | 4- 30u" 5- 50u" |
| 3-W/ SIDE TABS | T-TIN |
| 4-W/ TOP&SIDE TABS | V-NICKEL |
| 5-W/ TOP&BOTTOM&SIDE TABS | J- W/NICKEL PLATED WITH TINNED GROUNDING PEG |

DETACHED LISTS	MM (INCH)	DFTO JAMY	DATE 10/15/05	FULL RISE ELECTRONIC CO., LTD	
	TOLERANCES EXCEPT AS NOTED	CHKD JWE	DATE 2006/10/17		
		MFO	DATE		
		APPV Lushene	DATE 2006/10/17		
	MM			TITLE STAMPED PIN III	
	.0 ±0.2			W/ SHIELD JACK, 2X1	
	.00 ±0.15			DRAWING NO. GE593B76-LC	
	.000 ±0.075			/PART NO. SEE NOTE	
	ANGLES ± 0.5	MATERIAL :		SIZE A3	REV 0
	THIRD ANGLE PROJECTION	QTY :		DO NOT SCALE DRAWING	
		FINISH :		SHEET 1 OF 1	
		SCALE : 1.5 : 1			