

REVISION RECORD				
REV	ECO	DESCRIPTION	DRFT	CHKD

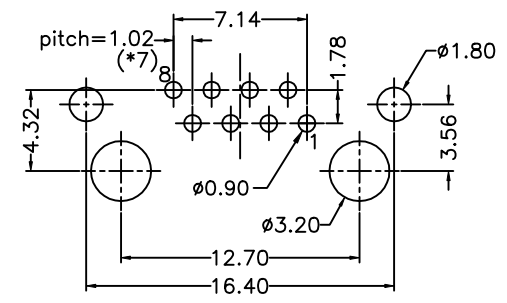
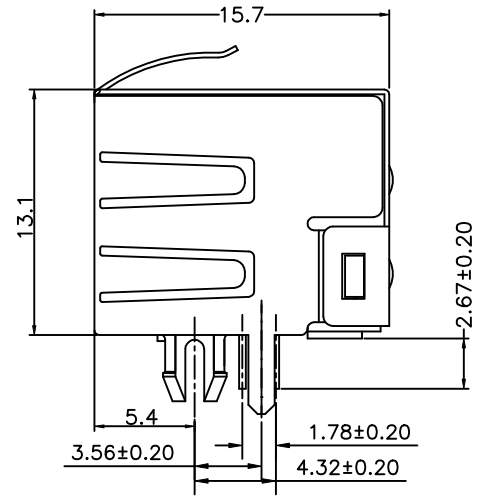
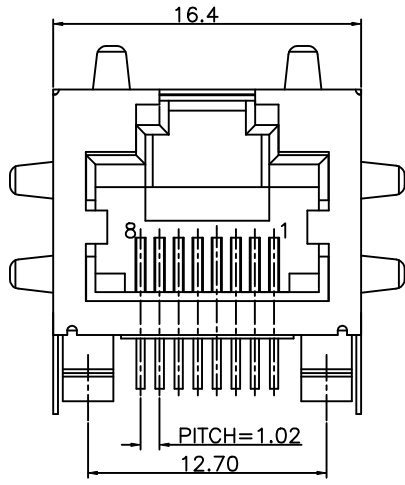

PCB (t=1.60mm) Layout  
Component Side Shown

**NOTES:**

**ELECTRICAL:**

- 1. VOLTAGE RATING : 125 VAC RMS.
- 2. CURRENT RATING : 1.5 AMP.
- 3. CONTACT RESISTANCE : 30 MILLIOHMS MAX.
- 4. INSULATION RESISTANCE: 1000 MEGOHMS MIN @ 500 VDC.
- 5. DIELECTRIC STRENGTH : 1000 VAC RMS 60Hz, 1MIN.
- 6. OPERATING: 750 CYCLES MIN.

**MECHANICAL:**

- 1. HOUSING MATERIAL : FR52 UL94V-0. COLOR-BLACK.
- 2. INSERT MATERIAL : FR52 UL94V-0. COLOR-BLACK.
- 3. BACK PLATE MATERIAL : FR52 COLOR-BLACK.
- 4. SHIELD MATERIAL : COPPER ALLOY 0.25mm THICKNESS PLATING NI.
- 5. CONTACT MATERIAL : PHOSPHOR BRONZE 0.35mm THICKNESS OR  $\phi$ 0.46mm.LEAD FREE.
- 6. PLATING : GOLD PLATING OVER NICKEL.
- 7. PCB RETENTION PRE-SOLDER : 1 LB MIN.
- 8. PCB RETENTION POST-SOLDER: 10 LBS MIN.

**ENVIRONMENTAL:**

- 1. STORAGE : -40°C TO +85°C.
  - 2. OPERATION: 0°C TO 70°C.
  - 3. WAVE SOLDERING TEMPERATURE:255~265\*(5~10 SECONDS)
- MATES WITH MODULAR PLUG CONFORMING TO  
FCC PART 68, SUBPART F.  
CUL FILE NO. E163191

ROHS PART NUMBER: E 5J 8 8 - X X L X X X -L

0-NO.LED  
6-HS'G&SHIELD NO LED

0-W/O SHIELD 1-NO TAB  
2-TOP TABS. 3-SIDE TABS.  
4-TOP TABS & SIDE TABS.

PLATING:1-3u" 2-6u" 3-15u"  
4-30u" 5-50u"  
A-TIN SHIELD STAMPED PIN  
B-NI SHIELD STAMPED PIN  
F-NI SHIELD ROUND PIN ( $\phi$ 0.46)  
J- FR52(A05-0130)  
5-W/O LOGO W/O TINNED SHIELD LEDS

DETACHED LISTS	MM (INCH)		DFTO yanglan DATE 05/20/05'	FULL RISE ELECTRONIC CO., LTD	
	TOLERANCES EXCEPT AS NOTED		CHKD JAKE DATE 2005/5/20		
	MM	±	MFO DATE	TITLE RJ45 W/O LED JACK	
	.0 ± 0.20	±	APPVLLUSHENG DATE 2005/5/20		
.00 ± 0.15	±	MATERIAL :	DRAWING NO. GE5J3A11-LA		
.000 ± 0.075	±	ANGLES ±	/PART NO. SEE NOTE		
THIRD ANGLE PROJECTION		QTY :	DO NOT SCALE DRAWING		
		FINISH :	SHEET 1 OF 1		
		SCALE :	SIZE A3 REV 0		