

DEL ROHS P/N	Qianpu 3/25/05	MODIFY DRAWING	YICUN 11/18/02	REVISION RECORD				
		ADD PART NUMBER	LY 11/21/02	REV	ECO	DESCRIPTION	DRFT	CHKD
		ADD PART NUMBER	LY 12/27/02			ADD PART NO	YINC 8/2/02	
		DRAWING MODIFY	LY 1/14/03			ADD PART NO	PSP 01/11/02	
		DRAWING MODIFY	LUXIN 11/16/04			MODIFY DRAWING	PSP 03/08/02	
		DRAWING MODIFY	LUXIN 12/25/04			ADD PART NO	PSP 04/01/02	

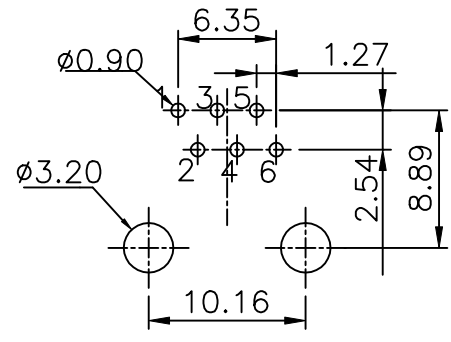
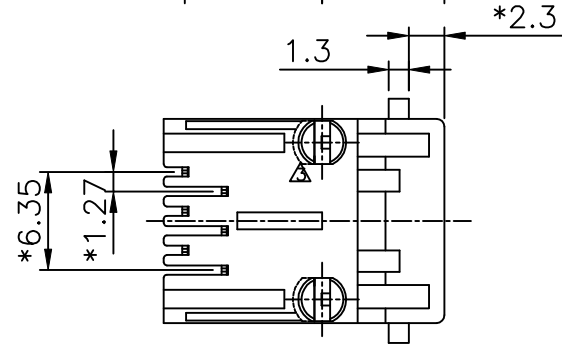
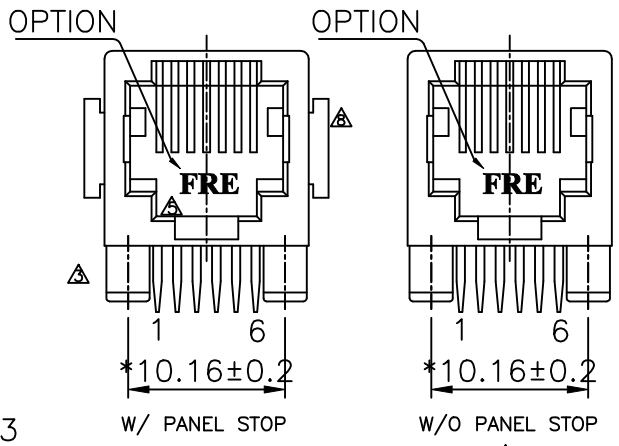
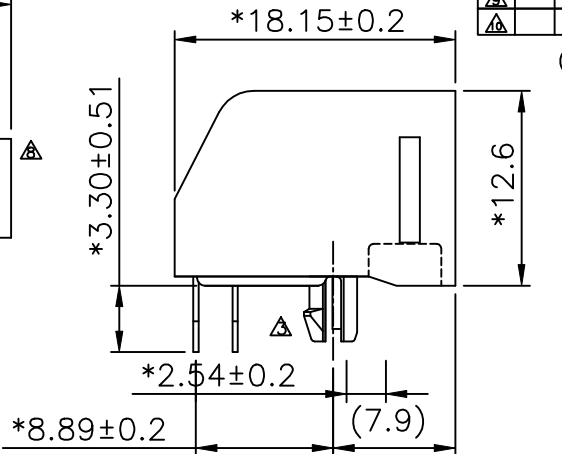
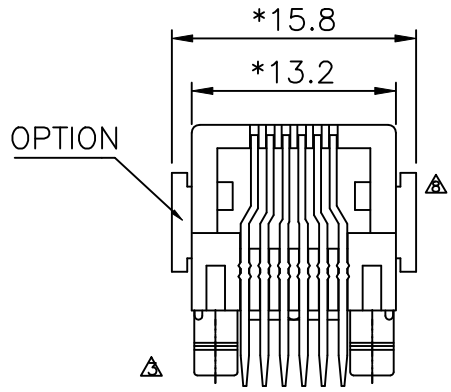

NOTES:

ELECTRICAL:

- VOLTAGE RATING : 125 VAC RMS.
- CURRENT RATING : 1.5 AMP.
- CONTACT RESISTANCE : 35 MILLIOHMS MAX.
- INSULATION RESISTANCE: 1000 MEGOHMS MIN @ 500 VDC.
- DIELECTRIC STRENGTH : 1000 VAC RMS 60Hz, 1MIN.

MECHANICAL:

- HOUSING MATERIAL : GLASS FILLED POLYESTER UL94V-0.
- CONTACT MATERIAL : PHOSPHOR BRONZE t=0.35mm.
- PLATING : GOLD PLATING OVER NICKEL.
- OPERATING LIFE : 750 CYCLES MIN.
- PCB RETENTION PRE-SOLDER : 1 LB MIN.
- PCB RETENTION POST-SOLDER: 10 LBS MIN.

ENVIRONMENTAL:

- STORAGE : -40°C TO +85°C.
- OPERATION: 0°C TO 70°C.  
MATES WITH MODULAR PLUG CONFORMING TO  
FCC PART 68, SUBPART F.  
CUL FILE NO. E163191
- PART NUMBER: E626X-000XXX

NO. OF CONTACT

- |      |        |        |
|------|--------|--------|
| 2-2C | 1- 3u" | 2- 6u" |
| 4-4C | 3-15u" | 4-30u" |
| 6-6C | 5-50u" |        |

- |                            |  |
|----------------------------|--|
| 0-PBT+30%.G.F BK           | 1- W/ PANEL STOP,W/O KEY,W/O "FRE" LOGO  |
| 1-PBT+15%.G.F BK           | 2- W/O PANEL STOP,W/O KEY,W/O "FRE" LOGO |
| 2-PBT+30%.G.F BK           | A- W/ PANEL STOP,W/O KEY,W/ "FRE" LOGO   |
| 3-FR50 BK                  | B- W/O PANEL STOP,W/O KEY,W/ "FRE" LOGO  |
| 6-PBT+30%.G.F Almond white |  |
| 7-FR52 BK                  |  |

DETACHED LISTS	MM (INCH)	DFTO BASS	DATE 5/22/98	FULL RISE ELECTRONIC CO., LTD	
	TOLERANCES EXCEPT AS NOTED	CHKD SAMMY	DATE 2005/3/26	TITLE	
	MM	MFO	DATE	AMP L/P SIDE ENTRY PCB JACK 6P	
	.0 ± 0.2	APPV LUSHENG	DATE 2005/3/26	DRAWING NO. GE623005	
.00 ± 0.15			/PART NO. SEE NOTE		
.000 ± 0.075			DO NOT SCALE DRAWING		
ANGLES ± 0.5	QT'Y :	MATERIAL :		SIZE A3	REV 11
THIRD ANGLE PROJECTION	FINISH :	SCALE : 3 : 1		SHEET OF	