

REVISION RECORD				
REV	ECD	DESCRIPTION	DRFT	CHKD
△		ADD P/N.	HERO 12/13/05	

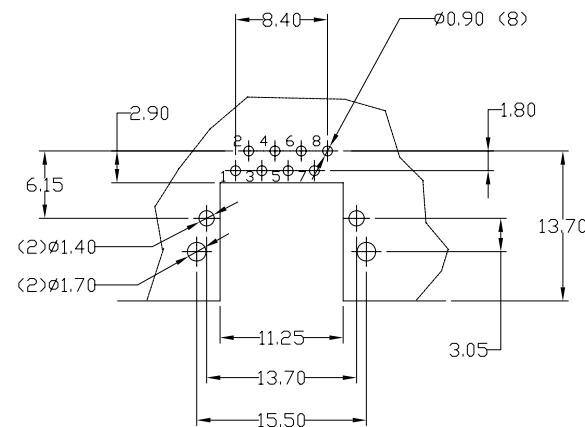
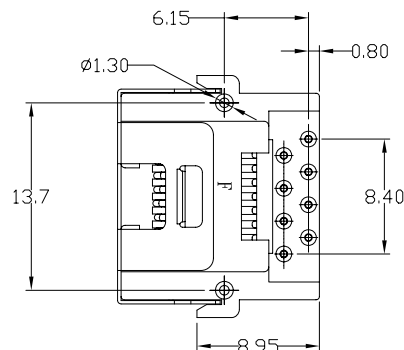
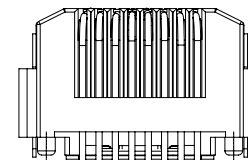
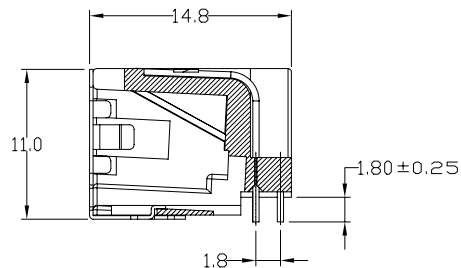
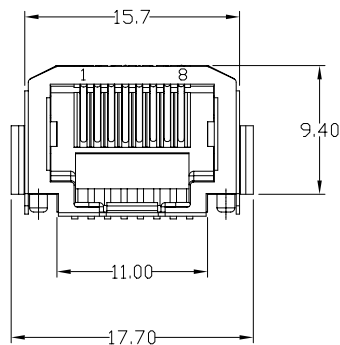

NOTES:

ELECTRICAL:

- 1. VOLTAGE RATING : 125 VAC RMS.
- 2. CURRENT RATING : 1.5 AMP.
- 3. CONTACT RESISTANCE : 30 MILLIOHMS MAX.
- 4. INSULATION RESISTANCE : 1000 MEGOHMS MIN @ 500 VDC
- 5. DIELECTRIC STRENGTH : 1000 VAC RMS 60HZ, 1MIN.

MECHANICAL:

- 1. HOUSING MATERIAL : PA66+30%G.F FR52UL94V- 0.
- 2. CONTACT MATERIAL : PHOSPHOR BRONZE 0.46mm
- 3. PLATING : GOLD PLATING OVER NICKEL.
- 4. OPERATING LIFE : 750 CYCLES MIN.
- 5. PCB RETENTION PRE-SOLDER : 1 LB MIN.
- 6. PCB RETENTION POS-SOLDER : 10 LBS MIN.

ENVIRONMENTAL:

- 1. STORAGE : -40°C TO +80°C
- 2. OPERATION: 0°C TO +70°C
- 3. WAVE SOLDERING TEMPERATURE: 255~265°C (5~10 SECONDS)

MATES WITH MODULAR PLUG CONFORMING TO FCC PART 68, SUBPART F.
FREE LEAD PART NUMBER: E6688-2C0XXX-L

GOLD PLATING
 1- 3u" 2-6u"
 3-15u" 4-30u"
 5-50u"
 22-FR52 BK
 82 PA66+30%G.F BK △

PC BOARD Thickness=0.60 ~ 0.80mm
 PC BOARD LAYOUT COMPONENT SIDE SHOWN

DETACHED LISTS	MM (INCH)	DFTD YAN	DATE 04/25/05	FULL RISE ELECTRONIC CO., LTD	
	TOLERANCES EXCEPT AS NOTED	CHKD	DATE		
	MM	MFD	DATE 12/14/05	TITLE RJ45-66DIP(8P)	
	.0 ± 0.2				
.00 ± 0.15			DRAWING NO. GE663A03-LA		
.000 ± 0.075					SIZE A3
ANGLES ± 0.5		QT'Y :	DD NOT SCALE DRAWING		SHEET 1 OF 1
THIRD ANGLE PROJECTION		FINISH:	SCALE : 2:1		