

NOTES: UNLESS OTHERWISE SPECIFIED

1.

NOTICE:	THIS IS A RoHS COMPLIANT COMPONENT/PRODUCT. ALL ENGINEERING CHANGES MUST HAVE PRIOR APPROVAL BY THE DESIGN CENTER.
RoHS	

2. PLASTIC: THERMOSET PLASTIC MATERIAL WITH FLAMMABILITY RATING UL 94V-0 OR BETTER.
3. SOLDERABILITY: CONFORMS TO ANSI/J-STD-002, 245°C REFLOW PEAK TEMPERATURE PER IPC/EIA J-STD-003A
4. OPERATING TEMPERATURE: 0°C TO +70°C
5. STORAGE TEMPERATURE: -20°C TO +125°C
6. JEDEC MOISTURE: LEVEL 1.
7. DIMENSIONS ARE IN INCHES WITH THE FOLLOWING TOLERANCES:  
.XX= ±.01 .XXX= ±.005
8. REVISION: MP1,MP2, ..... ARE PRELIMINARY.

ELECTRICAL CHARACTERISTICS AT +25°C UNLESS OTHERWISE SPECIFIED (FOR REFERENCE ONLY. USED FOR CUSTOMER INFORMATION.)

PARAMETER	SPECIFICATIONS
URNS RATIO (F=10 KHZ)	(1-3) : (16-14) = 1CT : 1CT ±2% (6-8) : (11-9) = 1CT : 2CT ±2% (16-15) : (15-14) = 1:1±2% WITH PINS (1-3) SHORTED (11-10) : (10-9) = 1:1± 2% WITH PINS (6-8) SHORTED
COUPLING CAPACITANCE	(1-3)-(16-14) = 8.0 pF MAX. (6-8)-(11-9) = 12.0 pF MAX. ( V=20mV, F=100 KHz)
LEAKAGE INDUCTANCE	(1-3)-(16-14) = 0.3 uH MAX. (6-8)-(11-9) = 0.20 uH MAX. ( V=20mV, F=100 KHz)
LP ( V=20mV, F=10 KHz)	(1-3) = 98 uH MIN. (11-9) = 70 uH MIN. 15 - (16-14) = 42 uH MIN.
DCR	(1-3), (16-14) = 0.6 OHM MAX. (6-8), (11-9) = 0.6 OHM MAX. (15-16), (15-14) = 0.3 OHM MAX. (10-11), (10-9) = 0.3 OHM MAX.
BETWEEN CHANNEL ISOLATION	1500 VAC FOR 60 SECONDS

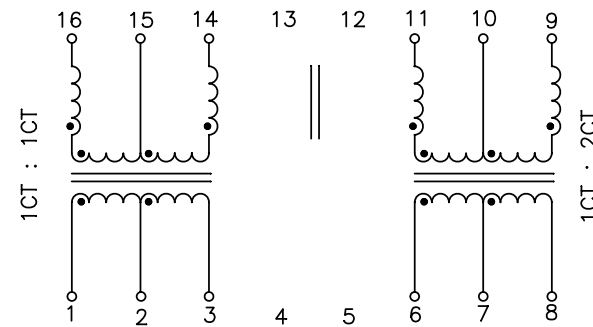
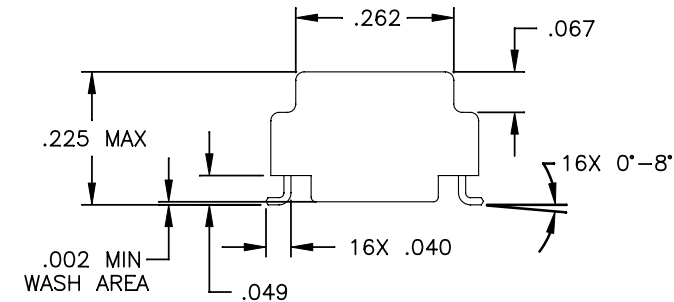
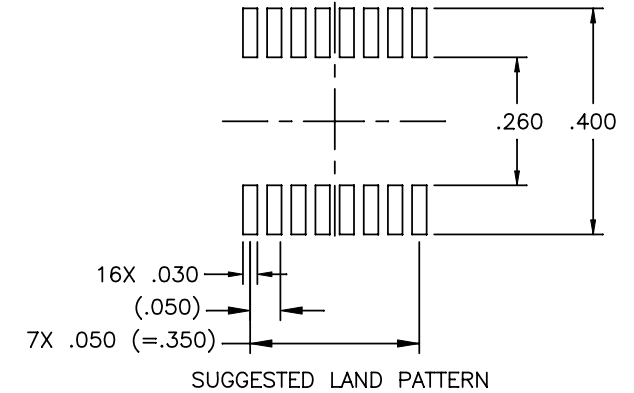
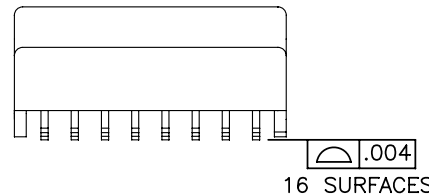
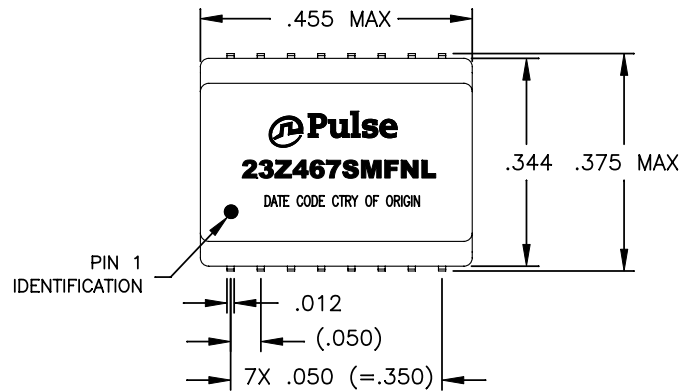

SCHEMATIC

© Copyright, 2013. Pulse Electronics Corp. All rights reserved. Drawing specifications subject to change without notice. (08/07/13)

PULSE CONFIDENTIAL & PROPRIETARY	PRODUCT DESCRIPTION	PS DRAWING	SHEET:	DWG. NO./ PART NO.	REV.
	MDL,SIN,10D,1:2,SM,TU	PS-2755.001-A	1	23Z467SMFNL	MP1