

10/100Base-TX Quad Port Transformer Modules

For Use with Transceivers Requiring 1:1 Transmit and Receive Turns Ratio

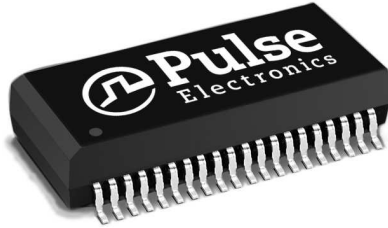

- RoHS peak reflow temperature rating: 245°C
- Meets IEEE 802.3 specification
- Models designed to support four single or double-stacked RJ-45 connectors

Electrical Specifications @ 25°C - Operating Temperature 0°C to 70°C

Part Number ¹	Insertion Loss (dB TYP)	Return Loss (dB TYP)					Crosstalk (dB TYP)				Common to Common Rejection Ratio 0.1-60 MHz (dB TYP)		Differential to Common Mode Rejection (dB TYP)	
		0.1-100 MHz	2-30 MHz	40 MHz	50 MHz	60-80 MHz	1 MHz	30 MHz	60 MHz	100 MHz	TX	RX	1-60 MHz	60-200 MHz
H1036LNL ^{2d}	-0.5	-21	-17	-14.5	-12	-65	-55	-45	-35	-30	-30	-40	-30	
H1044NL ^{2d}	-0.5	-21	-17	-14.5	-12	-65	-55	-45	-35	-30	-30	-40	-30	
H1053NL ^{2d}	-0.5	-21	-17	-14.5	-12	-65	-50	-40	-30	-30	-30	-40	-30	
H1060NL ^{2d}	-0.5	-21	-17	-14.5	-12	-65	-50	-40	-30	-30	-30	-40	-30	
H1062NL ^{2d}	-0.5	-21	-17	-14.5	-12	-65	-55	-45	-35	-30	-30	-40	-30	

1. For Tape & Reel packaging, add the suffix "T" to the end of the part number when ordering. e.g. H1044NLT.

2. MSL = Moisture Sensitivity Level a=1, b=2, c=3, d=4

Mechanicals

H10XXNL

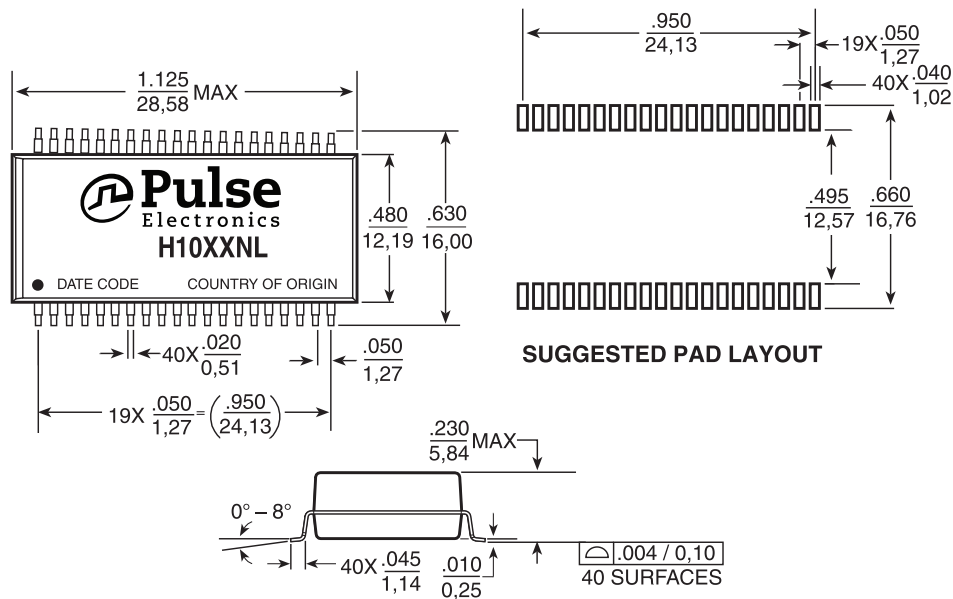

Weight4.0 grams TYP
 Tube15/tube
 Tape & Reel250/reel

Dimensions: $\frac{\text{Inches}}{\text{mm}}$ Unless otherwise specified, all tolerances are $\pm \frac{.10}{0.25}$

USA 858 674 8100

Germany 49 7032 7806 0

Singapore 65 6287 8998

Shanghai 86 21 62787060

China 86 755 33966678

Taiwan 886 3 4356768

10/100Base-TX Quad Port Transformer Modules



For Use with Transceivers Requiring 1:1 Transmit and Receive Turns Ratio

Quad-Port Solutions: These quad modules are designed to support four single or double stacked RJ-45 connectors. Each has a different pinout for optimization in layout with various IC manufacturers.

Schematics

H1036LNL

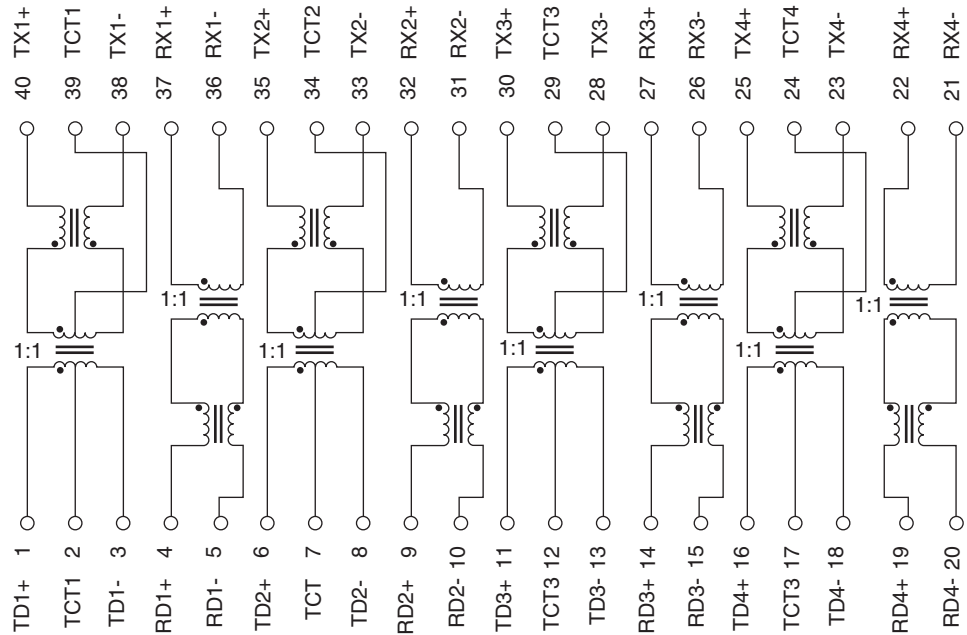
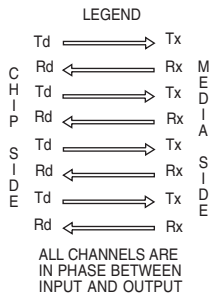

H1044NL

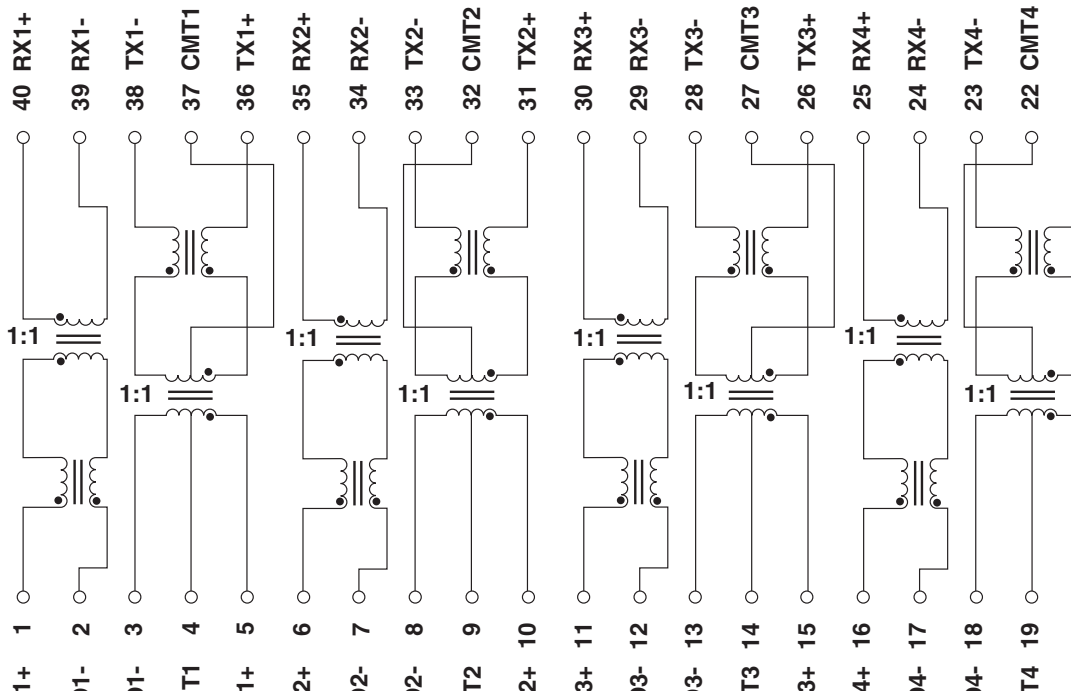
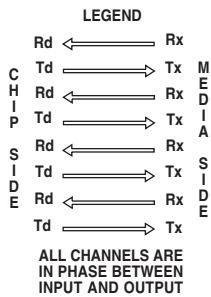

10/100Base-TX Quad Port Transformer Modules

For Use with Tranceivers Requiring 1:1 Transmit and Receive Turns Ratio

Schematics (continued)

H1053NL

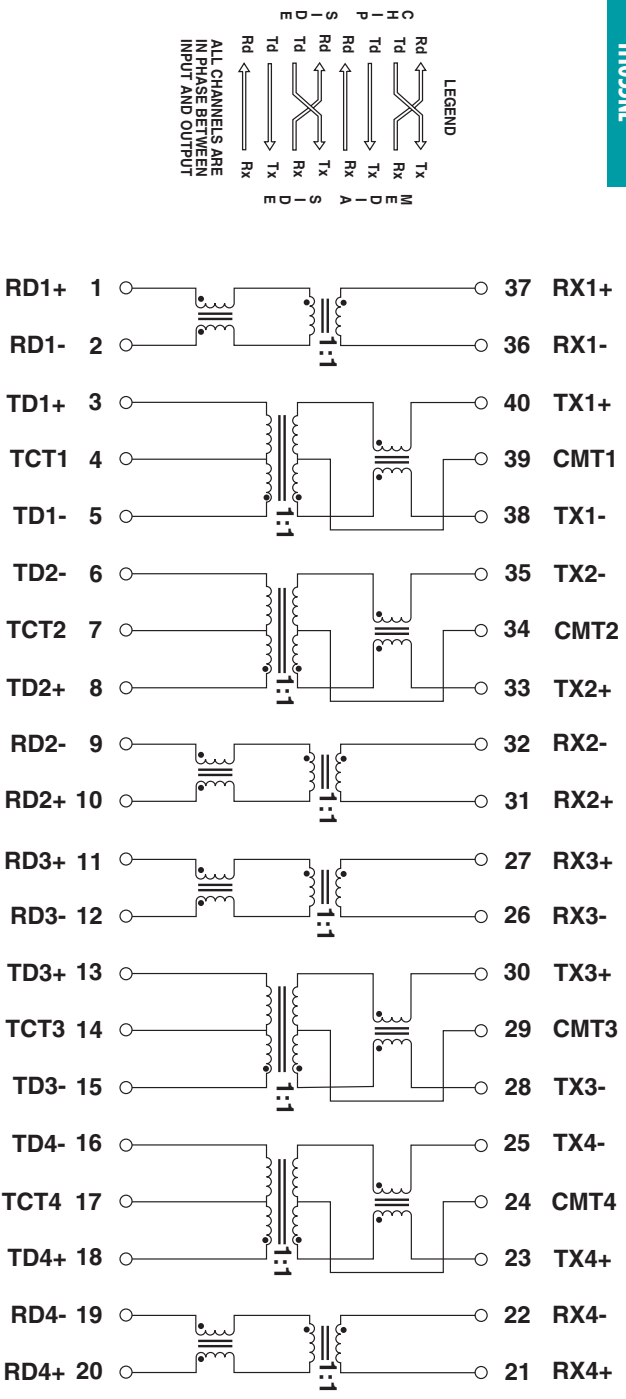

H1060NL

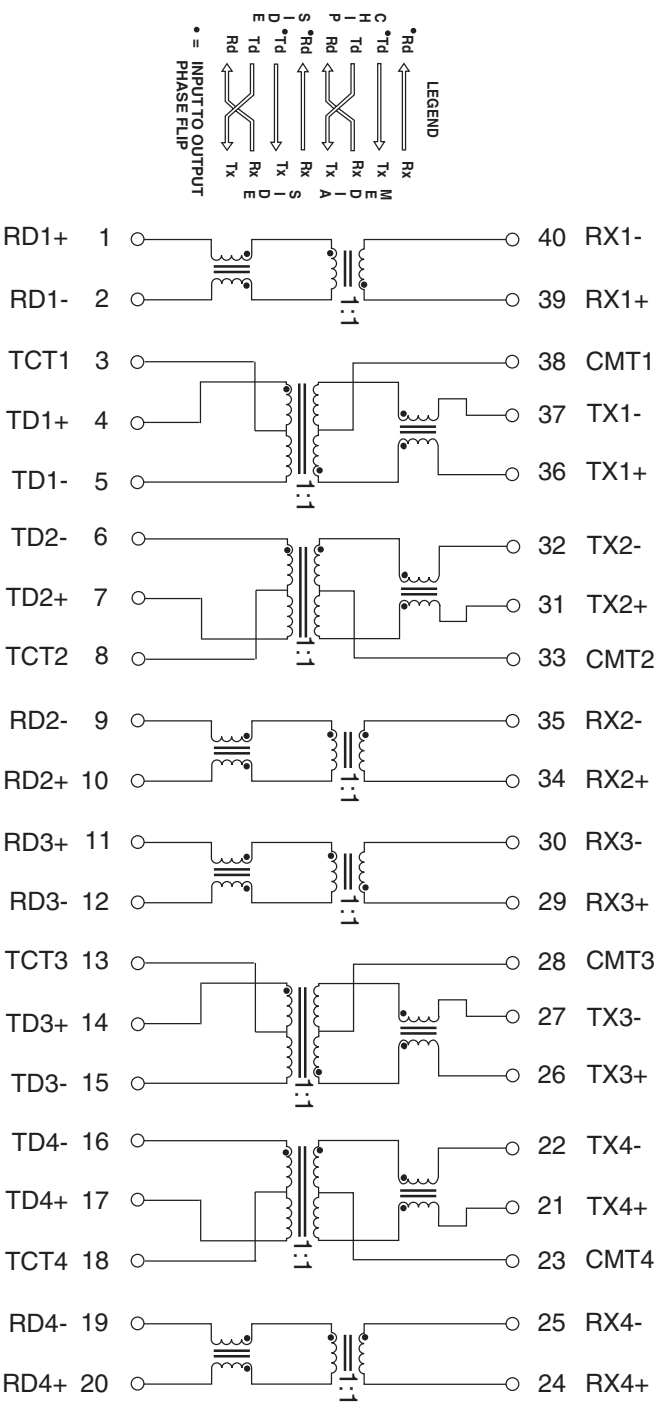

10/100Base-TX Quad Port Transformer Modules

For Use with Transceivers Requiring 1:1 Transmit and Receive Turns Ratio

Schematics (continued)

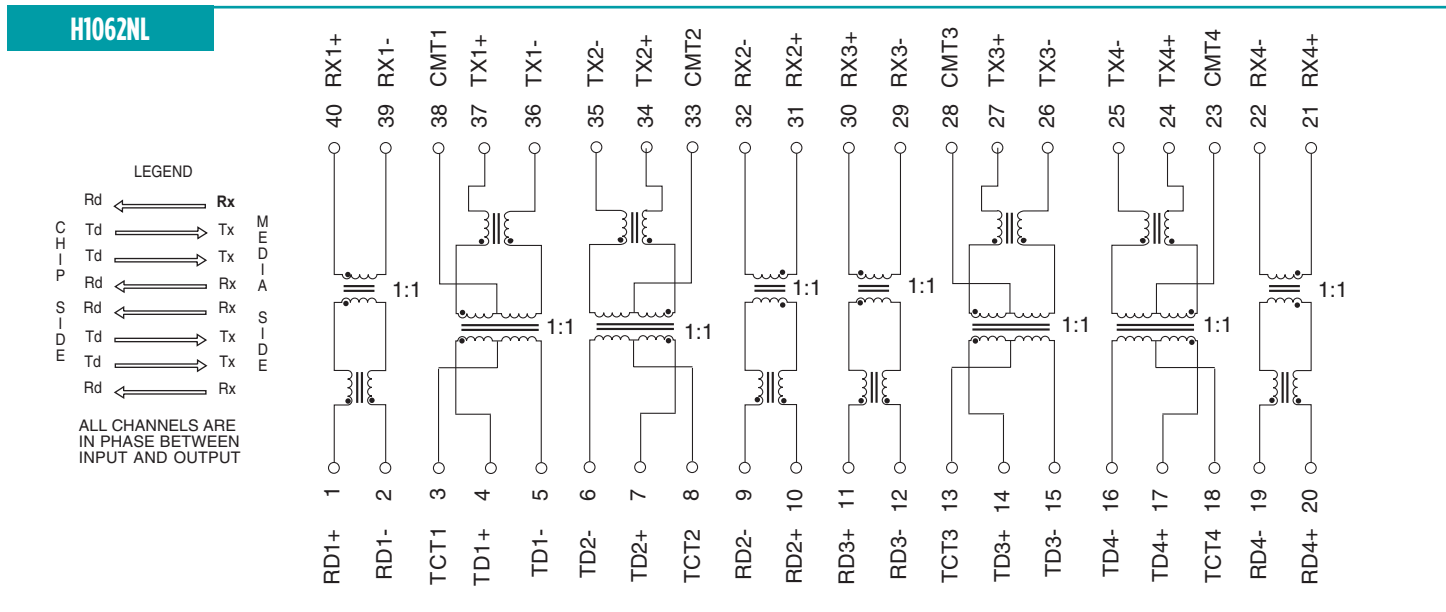

Tape & Reel Specifications

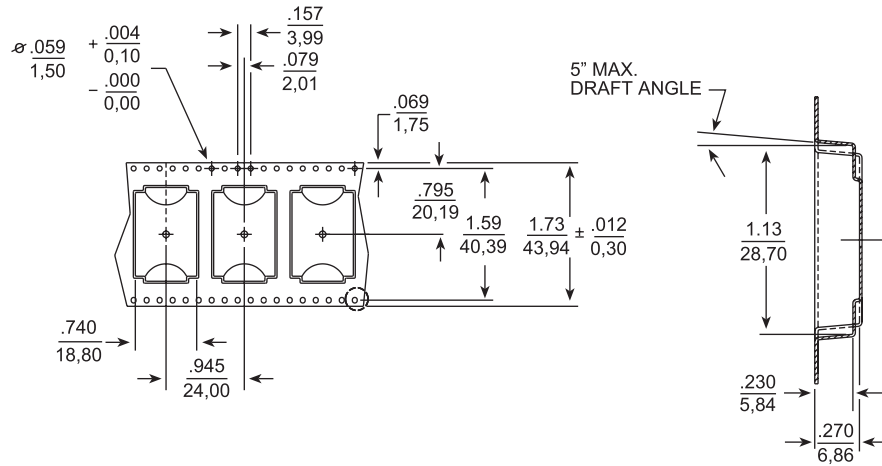

For More Information

Pulse Worldwide Headquarters
12220 World Trade Drive
San Diego, CA
92128
U.S.A.

Tel: 858 674 8100

Pulse Europe
Einsteinstrasse 1
D-71083 Herrenberg
Germany

Tel: 49 7032 7806

Pulse China Headquarters
B402, Shenzhen Academy of
Aerospace Technol-
ogy Bldg.
10th Kejian Road
High-Tech Zone
Nanshan District
Shenzen, PR China
518057

Pulse North China
Room 2704/2705
Super Ocean Finance
Ctr.
2067 Yan An Road
West
Shanghai 200336
China

Pulse South Asia
135 Joo Seng Road
#03-02
PM Industrial Bldg.
Singapore 368363

Tel: 65 6287 8998
Fax: 65 6287 8998

Pulse North Asia
3F, No. 198
Zhongyuan Road
Zhongli City
Taoyuan County 320
Taiwan R. O. C.
Tel: 886 3 4356768
Fax: 886 3 4356823
(Pulse)

Performance warranty of products offered on this data sheet is limited to the parameters specified. Data is subject to change without notice. Other brand and product names mentioned herein may be trademarks or registered trademarks of their respective owners. © Copyright, 2011. Pulse Electronics, Inc. All rights reserved.