

NOTES: UNLESS OTHERWISE SPECIFIED

1.

NOTICE:	THIS IS A RoHS COMPLIANT COMPONENT/PRODUCT. ALL ENGINEERING CHANGES MUST HAVE PRIOR APPROVAL BY THE DESIGN CENTER.
RoHS-6	
	

2. PLASTIC: THERMOSET PLASTIC MATERIAL WITH FLAMMABILITY RATING UL 94V-0 OR BETTER.
3. SOLDERABILITY: CONFORMS TO ANSI/J-STD-002 245°C REFLOW PEAK TEMPERATURE PER IPC/EIA J-STD-003A
4. OPERATING TEMPERATURE: -40°C TO +85°C
5. STORAGE TEMPERATURE: -50°C TO +125°C
6. JEDEC MOISTURE: LEVEL 1.
7. DIMENSIONS ARE IN INCHES WITH THE FOLLOWING TOLERANCES:  
.XX = ±.01  
.XXX = ±.005

ELECTRICAL CHARACTERISTICS:  
ELECTRICAL: @ +25°C

PARAMETER	SPECIFICATIONS	
OPERATING TEMP	-40°C ~ +85°C	
URNS RATIO	1.00 ± 2%	
POLARITY	PER SCHEMATIC	
INDUCTANCE (OCL) (MEDIA SIDE, -40 ~ +85°C)	350 uH MIN (MEASURED AT 100 KHz, 100 mVRMS) (AND WITH 8 mA DC BIAS)	
	440 uH MIN AT +25°C	
DC RESISTANCE	1-3, 16-14, 6-8, 11-9 = 1.50 OHMS MAXIMUM	
LEAKAGE INDUCTANCE 100 KHz, 100 mV	(1-3) WITH (16-14) SHORTED=0.3uH MAX (6-8) WITH (11-9) SHORTED=0.3uH MAX	
INSERTION LOSS	1-100 MHz	125 MHz
	-1.0 dB MAX	-3.0 dB MAX
RETURN LOSS	5 MHz	30-80 MHz
Z <sub>OUT</sub> = 100 OHMS	-18 dB MIN	-16 + 26LOG <sub>10</sub> (f/30 MHz) dB MIN
CROSSTALK (TX-RX)	1 MHz	5-100 MHz
	-62 dB MIN	-45 + 21LOG <sub>10</sub> (f/30 MHz) dB MIN
DIFFERENTIAL TO COMMON MODE REJECTION	5-200 MHz	
	-50 + 17LOG <sub>10</sub> (f/5 MHz) dB MIN	
ISOLATION (INPUT - OUTPUT)	VOLTAGE	TIME
	1650 VRMS	6 SECONDS MAX

NOTE: f IS FREQUENCY IN MHZ.



TRANSMIT

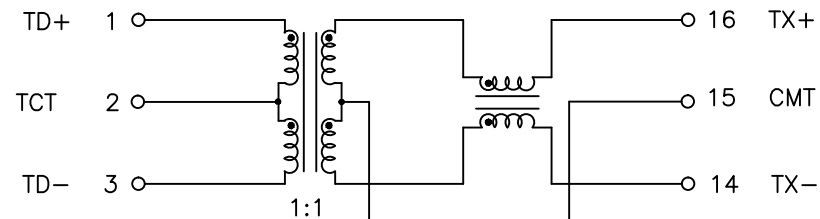

RECEIVE

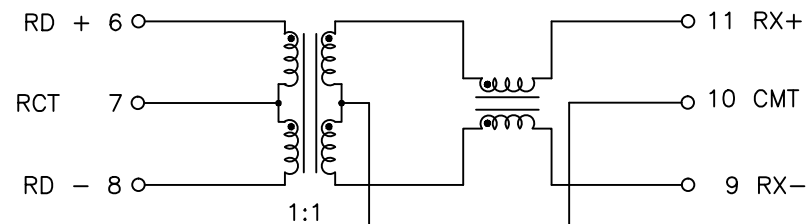

SCHEMATIC

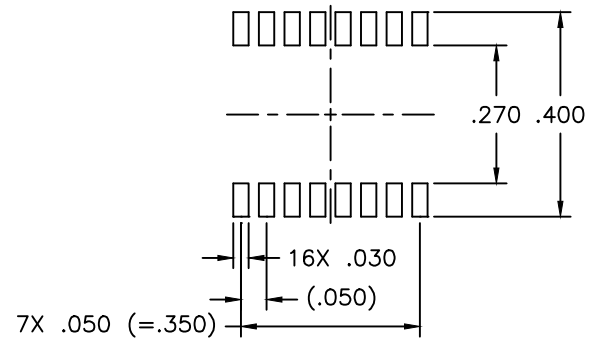
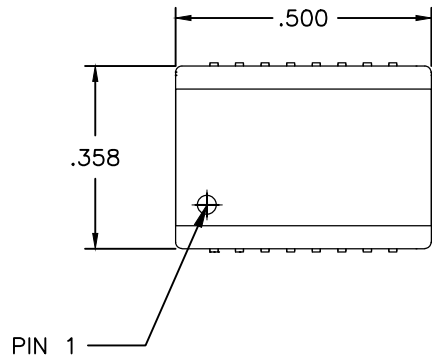

SUGGESTED LAND PATTERN

