

NOTES: UNLESS OTHERWISE SPECIFIED

- |         |  |
|---------|--|
| NOTICE: | THIS IS A RoHS COMPLIANT COMPONENT/PRODUCT. ALL ENGINEERING CHANGES MUST HAVE PRIOR APPROVAL BY THE DESIGN CENTER. |
| RoHS    |                                   |
- PLASTIC: THERMOSET PLASTIC MATERIAL WITH FLAMMABILITY RATING UL 94V-0 OR BETTER.
- SOLDERABILITY: CONFORMS TO ANSI/J-STD-002, 245°C REFLOW PEAK TEMPERATURE PER IPC/EIA J-STD-003A
- OPERATING TEMPERATURE: -40°C TO +85°C
- STORAGE TEMPERATURE: -50°C TO +125°C
- JEDEC MOISTURE: LEVEL 1.
- DIMENSIONS ARE IN INCHES, TOLERANCES:  
.XX = ±.01 .XXX = ±.005

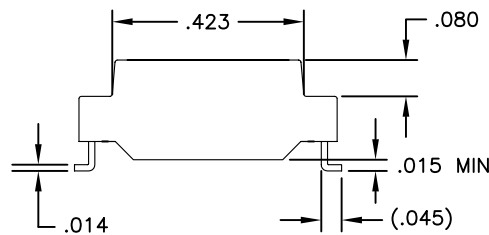
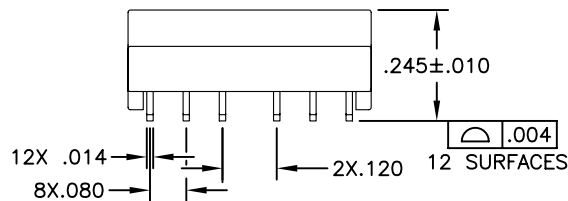
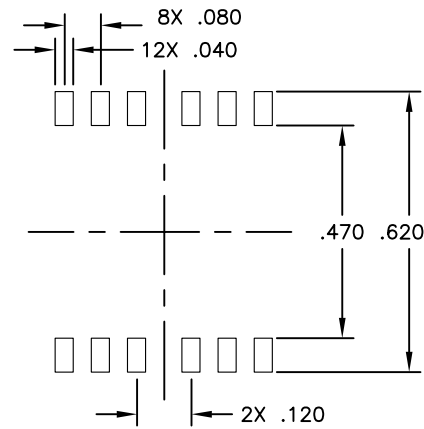
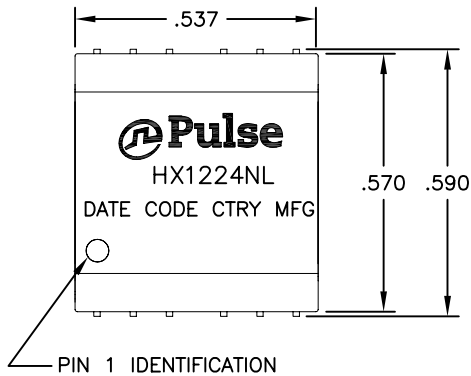

ELECTRICAL CHARACTERISTICS AT +25°C UNLESS OTHERWISE SPECIFIED (FOR REFERENCE ONLY. USED FOR CUSTOMER INFORMATION.)

PARAMETER	SPECIFICATIONS			
OPERATION TEMP	-40°C ~ +85°C			
URNS RATIO	1 : 1 ±2%			
POLARITY	PER SCHEMATIC			
OCL, TRANSMIT CHANNEL -40 TO +85 °C	350 uH MIN. AT 100KHz, 0.1VRMS WITH 8mA DC BIAS			
INSERTION LOSS	100 KHz	1-80 MHz	100 MHz	125 MHz
	-1.2 dB MAX	-1.0 dB MAX	-1.4 dB MAX	-3.0 dB MAX
RETURN LOSS (Z OUT = 100 OHM ±15%)	.5-15 MHz	30-45 MHz	45-60 MHz	60-80 MHz
	-18 dB MIN	-14 dB MIN	-10 dB MIN	-6 dB MIN
CROSSTALK (TX-RX)	1 MHz	30-100 MHz		
	-50 dB MIN	-55+24*LOG <sub>10</sub> (f/10 MHz) dB MIN		
DIFFERENTIAL TO COMMON MODE REJECTION	2 MHz	30-100 MHz		
	-50 dB MIN	-43+22*LOG <sub>10</sub> (f/30 MHz) dB MIN		
INPUT - OUTPUT ISOLATION	4000 VRMS FOR 1 MINUTE			

NOTE: f IS FREQUENCY IN MHZ.

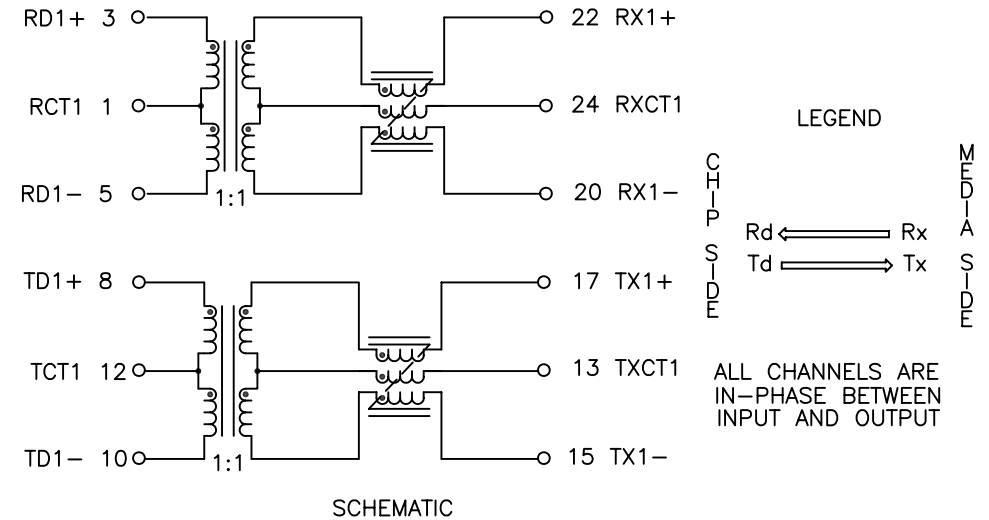

© Copyright, 2011. Pulse Electronics Corp. All rights reserved. Drawing specifications subject to change without notice. (05/25/11)

PULSE CONFIDENTIAL & PROPRIETARY	PRODUCT DESCRIPTION	PS DRAWING	SHEET:	DWG. NO./ PART NO.	REV.
	MDL,SIN,100D,1:1,SM,TU	PS-2611.001-B	1	HX1224NL	M12