

NOTES: UNLESS OTHERWISE SPECIFIED

1.

NOTICE:	THIS IS A RoHS COMPLIANT COMPONENT/PRODUCT. ALL ENGINEERING CHANGES MUST HAVE PRIOR APPROVAL BY THE DESIGN CENTER.
RoHS-6 ✓	

2. PLASTIC: THERMOSET PLASTIC MATERIAL WITH FLAMMABILITY RATING UL 94V-0 OR BETTER.
3. SOLDERABILITY: CONFORMS TO ANSI/J-STD-002 245°C REFLOW PEAK TEMPERATURE PER IPC/EIA J-STD-003A
4. OPERATING TEMPERATURE: -40°C TO +85°C
5. STORAGE TEMPERATURE: -50°C TO +125°C
6. JEDEC MOISTURE: LEVEL 1.
7. DIMENSIONS ARE IN INCHES WITH THE FOLLOWING TOLERANCES:
.XX = ±.01
.XXX = ±.005

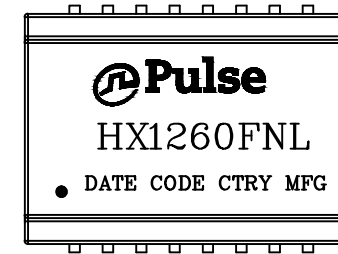

ELECTRICAL CHARACTERISTICS:
ELECTRICAL: @ +25°C

PARAMETER	SPECIFICATIONS		
	100 KHz	1-125 MHz	
INSERTION LOSS	-1.2 dB MAX	-0.2-0.002*f ^{1.4} dB MAX	
RETURN LOSS (Z OUT = 100 OHM ±15%)	.1-30 MHz	30-60 MHz	60-80 MHz
	-16 dB MIN	-10+20*LOG ₁₀ (f/60 MHz) dB MIN	-10 dB MIN
INDUCTANCE (OCL) (MEDIA SIDE, 0°C-70°C)	400 uH MIN (MEASURED AT 100 KHz, 100 mVRMS)		
INDUCTANCE (OCL) (MEDIA SIDE, -40°C TO +85°C)	350 uH MIN (MEASURED AT 100 KHz, 100 mVRMS)		
CROSSTALK, ADJACENT CHANNELS	1 MHz	10-100 MHz	
	-50 dB MIN	-55+22*LOG ₁₀ (f/10) dB MIN	
COMMON MODE REJECTION RATIO	2 MHz	30-200 MHz	
	-50 dB MIN	-15+20*LOG ₁₀ (f/200) dB MIN	
DC RESISTANCE, 1/2 WINDING	.65 OHMS MAX		
DC RESISTANCE IMBALANCE	±.065 OHMS MAX (CENTER TAP SYMMETRY)		
INPUT - OUTPUT ISOLATION	1500 VRMS MIN @ 60 SECONDS		

NOTE: f IS FREQUENCY IN MHz.

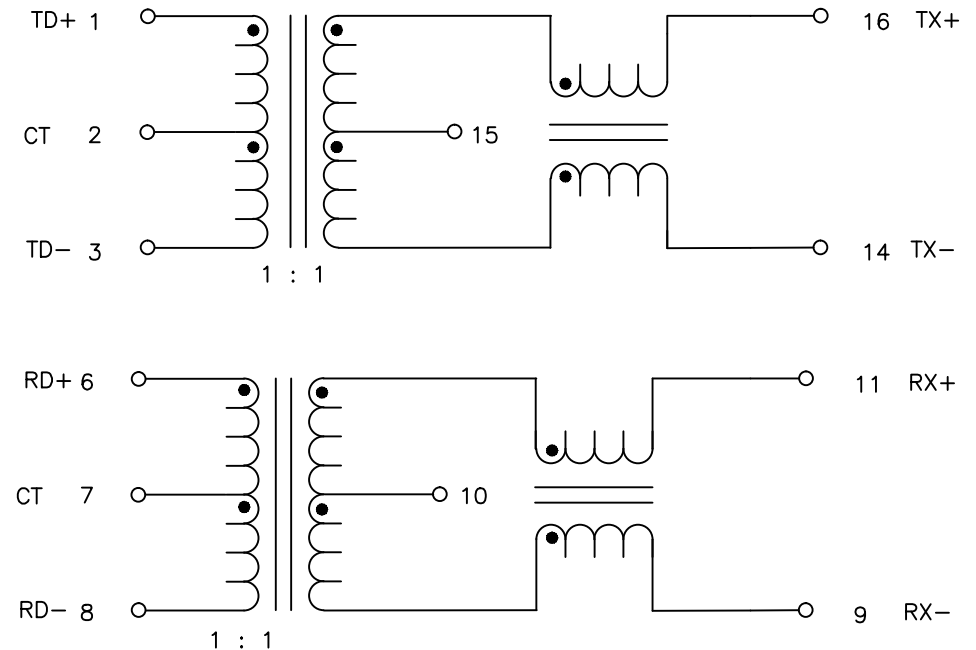

SCHEMATIC

© Copyright, 2013. Pulse Electronics, Inc. All rights reserved. Drawing specifications subject to change without notice. (8/2/13)

PULSE CONFIDENTIAL
&
PROPRIETARY

PRODUCT DESCRIPTION
MDL,SIN,100D,1:1,SMT

PS DRAWING
PS-2005.002-C

SHEET:
1

DWG. NO./ PART NO.
HX1260FNL

REV.
M10

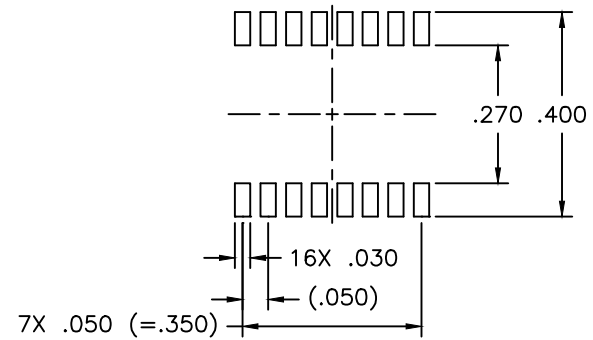
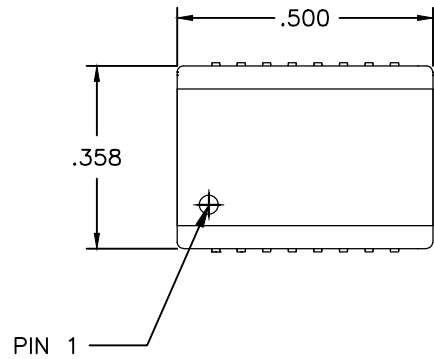

SUGGESTED LAND PATTERN

