



NOTES: UNLESS OTHERWISE SPECIFIED

- THIS COMPONENT CONFORMS TO UL60950. UL FILE NO. IS: E216117.

	WARNING: THIS COMPONENT IS RECOGNIZED BY ONE OR MORE SAFETY AGENCIES SUCH AS UL, VDE, CSA AND/OR TUV. ALL ENGINEERING CHANGES MUST HAVE PRIOR APPROVAL BY THE DESIGN CENTER QUALITY DEPARTMENT FOR SAFETY AGENCY COMPLIANCE.	ECN APPROVAL:
		QA APPROVAL:
		DATE:

- | | |
|---|---|
|  | NOTICE: THIS IS A RoHS COMPLIANT COMPONENT/PRODUCT. ALL ENGINEERING CHANGES MUST HAVE PRIOR APPROVAL BY THE DESIGN CENTER. |
| | |

- PLASTIC HOUSING: THERMOPLASTIC MATERIAL WITH FLAMMABILITY RATING UL 94V-0 OR BETTER.
- CONTACT BASE MATERIAL: PHOSPHOR BRONZE.
- CONTACTS UNDERPLATE: 50 MICROINCHES DUCTILE NICKEL.
- CONTACTS PLATING: 15 MICROINCHES GOLD PLATING.
- SOLDER TAIL PLATING MATERIAL: 100-300 MICROINCHES 100% TIN, MATTE FINISH.
- METAL SHIELD: NICKEL PLATING ON COPPER ALLOY.
- JACK CAVITY CONFORMS TO FCC RULES AND REGULATIONS PART 68 SUBPART F.
- PCB PLATING: ENIG
- SOLDERABILITY: CONFORMS TO ANSI/J-STD-002, IPC/EIA J-STD-003A.
- OPERATING TEMPERATURE: 0°C TO +70°C
- STORAGE TEMPERATURE: -20°C TO +125°C
- JEDEC MOISTURE: LEVEL 1.
- DIMENSIONS ARE IN INCHES [MILLIMETERS] WITH THE FOLLOWING TOLERANCES: [MILLIMETERS] ARE FOR REFERENCE ONLY.
.XX = ±0.02 [±0.5]
.XXX = ±0.010 [±0.25]

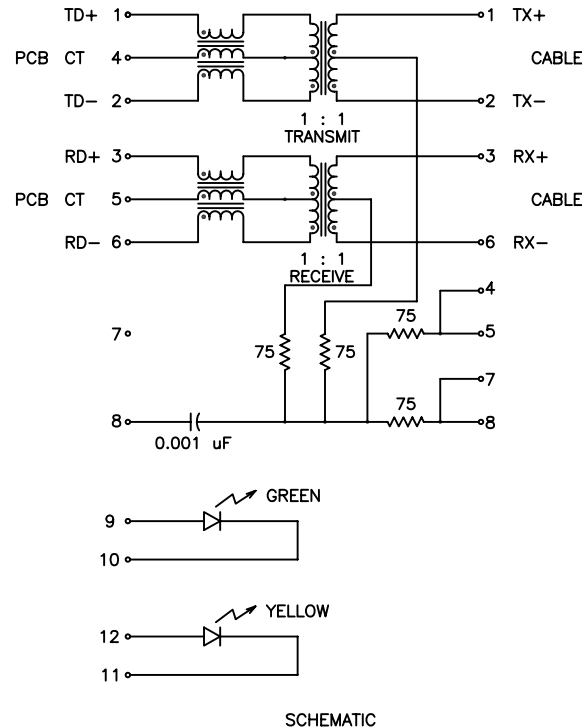

ELECTRICAL CHARACTERISTICS AT +25°C UNLESS OTHERWISE SPECIFIED (FOR REFERENCE ONLY. USED FOR CUSTOMER INFORMATION.)

PARAMETER	SPECIFICATIONS		
OPERATING TEMP	0°C - 70°C		
URNS RATIO	1 : 1 ±2%		
POLARITY	PER SCHEMATIC		
INSERTION LOSS	100 KHz	1-125 MHz	
	-1.2 dB MAX	-0.2-0.002*f ^{1.4} dB MAX	
RETURN LOSS (Z OUT = 100 OHM±15%)	.1-30 MHz	30-60 MHz	60-80 MHz
	-16 dB MIN	-10+20*LOG ₁₀ (f/60 MHz) dB MIN	-10 dB MIN
	INDUCTANCE (OCL) (MEDIA SIDE, 0°C-70°C)		
CROSSTALK, ADJACENT CHANNELS	1 MHz	10-100 MHz	
	-50 dB MIN	-50+17*LOG ₁₀ (f/10) dB MIN	
COMMON MODE REJECTION RATIO	2 MHz	30-200 MHz	
	-50 dB MIN	-15+20*LOG ₁₀ (f/200) dB MIN	
DC RESISTANCE 1/2 WINDING	.60 OHMS MAX		
DC RESISTANCE IMBALANCE	±.065 OHMS MAX (CENTER TAP SYMMETRY)		
INPUT - OUTPUT ISOLATION	1500 VRMS MIN @ 60 SECONDS		

NOTE: f IS FREQUENCY IN MHz.

EMMITTED COLOR	GREEN	YELLOW
WAVELENGTH (nm)	568 nm	585 nm
BRIGHTNESS (mCD)	12 TYP. @ 20mA	10 TYP. @ 20 mA
VIEWING ANGLE	100°	100°
POWER DISSIPATION (Pd)	68 mW MAX	68 mW MAX
DC FORWARD CURRENT	150 mA MAX	150 mA MAX
FORWARD VOLTAGE (Vf)	2.2 TO 2.7 VOLTS	2.1 TO 2.7 VOLTS
REVERSE VOLTAGE (Vr)	5.0 V MAX	5.0 V MAX

NOTE: PER VENDOR'S SPECIFICATIONS

© Copyright, 2010. Pulse Electronics Corp. All rights reserved. Drawing specifications subject to change without notice. (01/10/11)

PULSE CONFIDENTIAL & PROPRIETARY	PRODUCT DESCRIPTION	PS DRAWING	SHEET:	DWG. NO./ PART NO.	REV.
	CONN,RJ45,1X1,100D,1:1,TU	PS-2163.001-F	1	J00-0213NL	M10

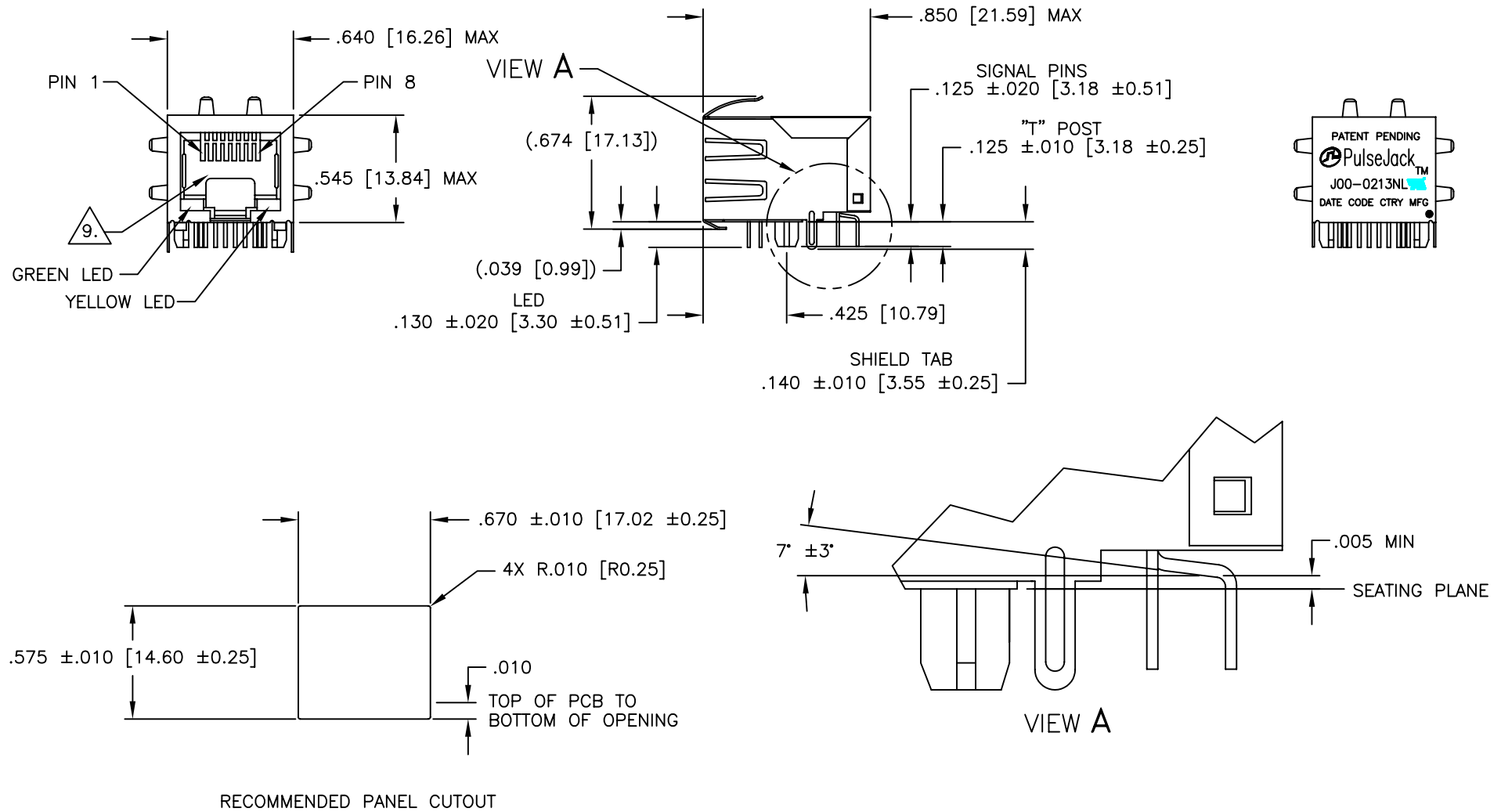

© Copyright, 2010. Pulse Electronics Corp. All rights reserved. Drawing specifications subject to change without notice. (01/10/11)

PULSE CONFIDENTIAL & PROPRIETARY	PRODUCT DESCRIPTION	PS DRAWING	SHEET:	DWG. NO./ PART NO.	REV.
		CONN,RJ45,1X1,100D,1:1,TU	PS-2163.001-F	2	J00-0213NL

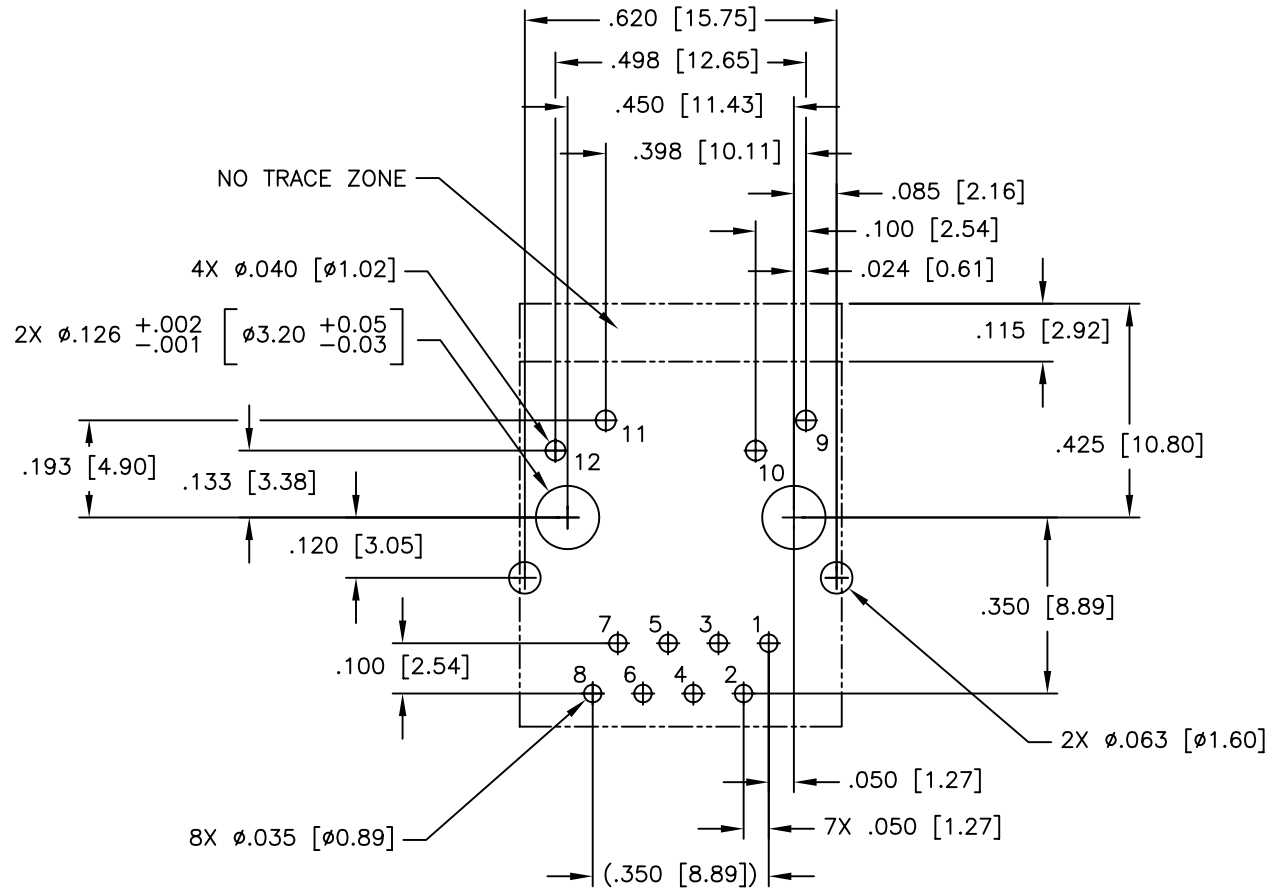

SUGGESTED PC BOARD LAYOUT VIEWED FROM COMPONENT SIDE
PCB LAYOUT DIMENSIONS TO BE ± 0.002 UNLESS OTHERWISE SPECIFIED

© Copyright, 2010. Pulse Electronics Corp. All rights reserved. Drawing specifications subject to change without notice. (01/10/11)

PULSE CONFIDENTIAL & PROPRIETARY	PRODUCT DESCRIPTION	PS DRAWING	SHEET:	DWG. NO./ PART NO.	REV.
		CONN,RJ45,1X1,100D,1:1,TU	PS-2163.001-F	3	J00-0213NL