



NOTES: UNLESS OTHERWISE SPECIFIED

1. THIS COMPONENT CONFORMS TO UL60950, UL FILE NO. IS: E216117.

	WARNING: THIS COMPONENT IS RECOGNIZED BY ONE OR MORE SAFETY AGENCIES SUCH AS UL, VDE, CSA AND/OR TUV. ALL ENGINEERING CHANGES MUST HAVE PRIOR APPROVAL BY THE DESIGN CENTER QUALITY DEPARTMENT FOR SAFETY AGENCY COMPLIANCE.	EDN APPROVAL: QA APPROVAL: DATE:

	NOTICE: THIS IS A RoHS COMPLIANT COMPONENT/PRODUCT. ALL ENGINEERING CHANGES MUST HAVE PRIOR APPROVAL BY THE DESIGN CENTER.

3. PLASTIC HOUSING: THERMOPLASTIC MATERIAL WITH FLAMMABILITY RATING UL 94V-0 OR BETTER.
4. CONTACT BASE MATERIAL: PHOSPHOR BRONZE.
5. CONTACTS UNDERPLATE: 50 MICROINCHES DUCTILE NICKEL.
6. CONTACTS PLATING: 30 MICROINCHES GOLD PLATING.
7. SOLDER TAIL PLATING MATERIAL: 150-300 MICROINCHES 100% TIN, MATTE FINISH.
8. METAL SHIELD: NICKEL PLATING ON COPPER ALLOY.
9. JACK CAVITY CONFORMS TO FCC RULES AND REGULATIONS PART 68 SUBPART F.
10. PCB PLATING: ENIG
11. SOLDERABILITY: CONFORMS TO ANSI/J-STD-002, IPC/EIA J-STD-003A.
12. OPERATING TEMPERATURE: 0°C TO +70°C
13. STORAGE TEMPERATURE: -20°C TO +125°C
14. JEDEC MOISTURE: LEVEL 1.
15. DIMENSIONS ARE IN INCHES [MILLIMETERS] WITH THE FOLLOWING TOLERANCES: [MILLIMETERS] ARE FOR REFERENCE ONLY.
 .XX= ±0.02 [±0.5]
 .XXX= ±0.010 [±0.25]

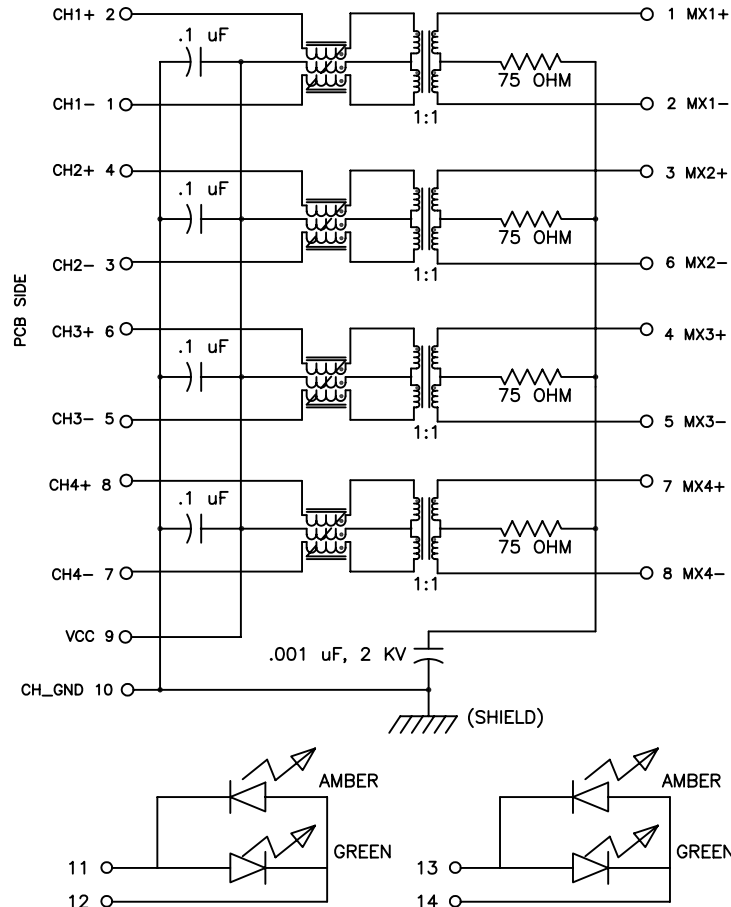

SCHEMATIC

ELECTRICAL CHARACTERISTICS AT +25°C UNLESS OTHERWISE SPECIFIED (FOR REFERENCE ONLY. USED FOR CUSTOMER INFORMATION.)

PARAMETER	SPECIFICATIONS	
OPERATING TEMP	0°C - 70 °C	
TURNS RATIO	1 : 1 ±2%	
POLARITY	PER SCHEMATIC	
INSERTION LOSS	100 KHz	1-125 MHz
	-1.2 dB MAX	-0.2-0.002*f ^{1.4} dB MAX
RETURN LOSS (Z OUT = 100 OHM ±15%)	.1-40 MHz	40-100 MHz
	-16 dB MIN	-10+20*LOG ₁₀ (f/80 MHz) dB MIN
INDUCTANCE (OCL) (MEDIA SIDE, 0°C-70°C)	350 uH MIN (MEASURED AT 100 KHz, 100 mVRMS AND WITH 8 mA DC BIAS)	
CROSSTALK, ADJACENT CHANNELS	1 MHz	10-100 MHz
	-50 dB MIN	-55+22*LOG ₁₀ (f/10) dB MIN
COMMON MODE REJECTION RATIO	2 MHz	30-200 MHz
	-50 dB MIN	-15+20*LOG ₁₀ (f/200) dB MIN
INPUT - OUTPUT ISOLATION	2250 VDC MIN @ 60 SECONDS	

NOTE: f IS FREQUENCY IN MHZ.

EMMITTED COLOR	AMBER	GREEN
WAVELENGTH (nm)	568 nM	600 ±5 nM
BRIGHTNESS (mCD)	5 TO 7 TYP. @ 10mA	5 TO 7 TYP. @ 10mA
VIEWING ANGLE	85°-100°	85°-100°
POWER DISSIPATION (Pd)	100 mW MAX	100 mW MAX
DC FORWARD CURRENT	150 mA MAX	150 mA MAX
FORWARD VOLTAGE (Vf)	2.1 TO 2.6 VOLTS	2.1 TO 2.6 VOLTS
REVERSE VOLTAGE (Vr)	5.0 V MAX	5.0 V MAX

NOTE: PER VENDOR'S SPECIFICATIONS

© Copyright, 2010. Pulse Engineering, Inc. All rights reserved. Drawing specifications subject to change without notice. (06/17/10)

PULSE CONFIDENTIAL & PROPRIETARY	PRODUCT DESCRIPTION	PS DRAWING	SHEET:	DWG. NO./ PART NO.	REV.
	CONN,RJ45,1X4,1GD,1:1,TY	PS-2098.003-N	1	JG0-0098NL	M12

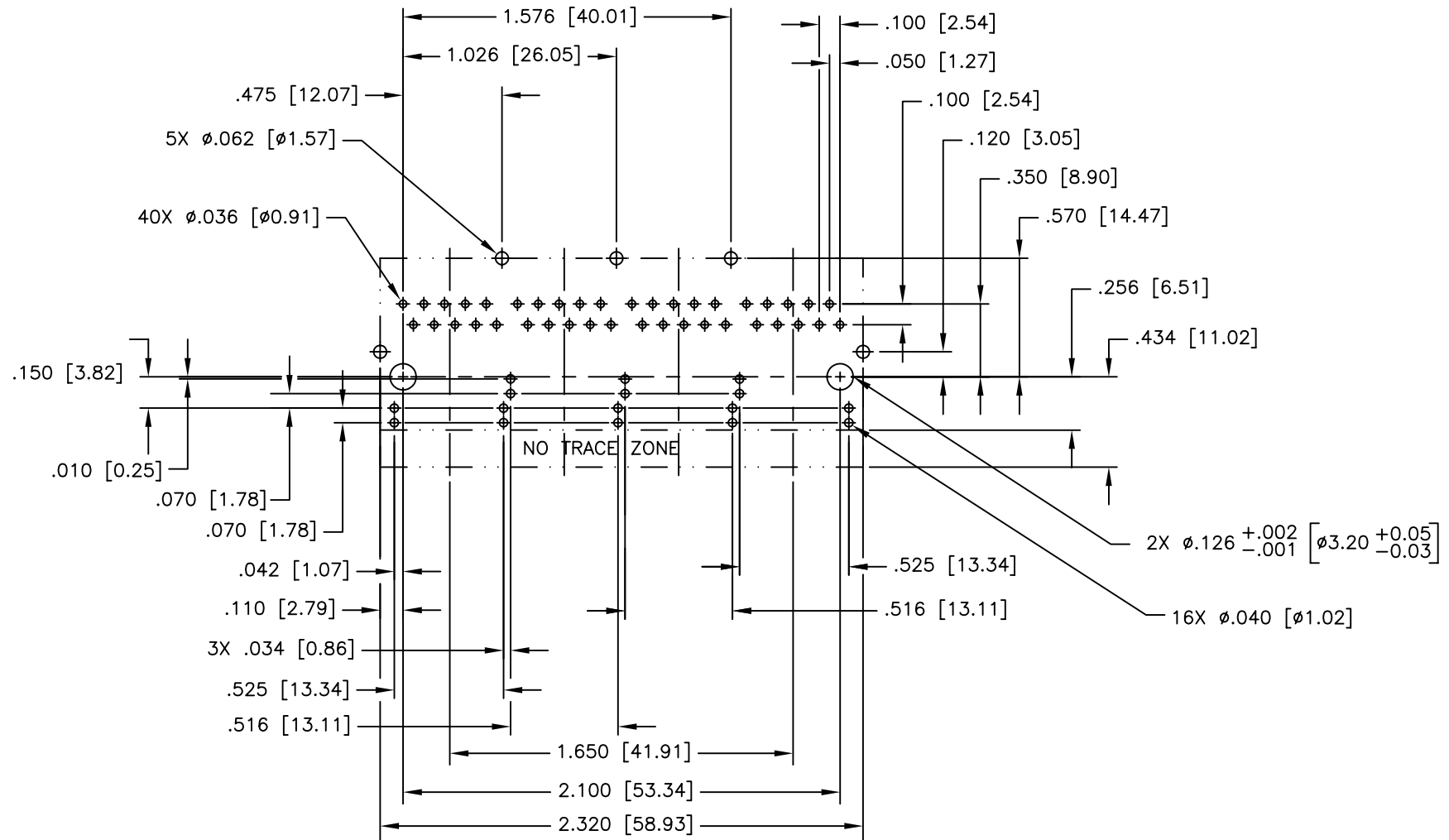

SUGGESTED FOOTPRINT (COMPONENT SIDE SHOWN)
DIMENSIONAL TOLERANCE: (UNLESS OTHERWISE SPECIFIED)
.XXX ±.003 [X.XX ±0.08]

© Copyright, 2010. Pulse Engineering, Inc. All rights reserved. Drawing specifications subject to change without notice. (06/17/10)

PULSE CONFIDENTIAL & PROPRIETARY	PRODUCT DESCRIPTION	PS DRAWING	SHEET:	DWG. NO./ PART NO.	REV.
		CONN,RJ45,1X4,1GD,1:1,TY	PS-2098.003-N	3	JG0-0098NL