



# SMT POWER INDUCTORS

## Toroid - Military/Aerospace SLED Series



-  Ruggedized header with SLED rails for secure board mounting
-  **Current Rating:** up to 3.8A<sub>DC</sub>
-  **Inductance Range:** 9.4μH to 439μH

### Electrical Specifications @ 25°C — Operating Temperature -40°C to +130°C

Part # Number	Inductance @ I <sub>rated</sub> (μH)	I <sub>rated</sub> (A)	DCR (mΩ)		ET (V-μsec)	Inductance @ 0A <sub>DC</sub> (μH ±10%)	100 Gauss ET <sub>100</sub> (V-μsec)	1 Amp DC H <sub>1</sub> (Orsted)
			TYP	MAX				
<b>SLED 25</b>								
PL8500	9.4	3.80	27	32	15.2	10.4	2.65	11.95
PL8501	13.3	3.20	40	46	18.8	14.6	3.13	14.12
PL8502	23	2.40	65	74	24.3	25	4.10	18.46
PL8503	50	1.60	121	135	37.0	56	6.15	27.69
PL8504	75	1.30	181	220	44.3	83	7.47	33.67
PL8505	90	1.20	246	285	49.2	100	8.19	36.93
PL8506	137	1.00	387	425	59.4	152	10.12	45.61
PL8507	200	0.82	585	673	71.3	220	12.17	54.85
PL8508	305	0.66	845	972	85.8	331	14.94	67.34
PL8509	439	0.56	1322	1520	99.6	472	17.83	80.37

- NOTES:**
- The reference inductance at rated DC current is a typical value.
  - Temperature rise is 50°C in typical buck or boost circuits at 250kHz and with the reference ET applied to the inductor.
  - Total loss in the inductor is 380mW for 50°C temperature rise above ambient.
  - To estimate temperature rise in a given application, determine copper and core losses, divide by 380 and multiply by 50.
  - For the copper loss, calculate  $I_{DC}^2 \times R_N$ .
  - For core loss, using frequency (f) and operating flux density (B), calculate  $6.11 \times 10^{-18} \times B^{2.7} \times f^{2.04}$ .
  - For flux density (B), calculate ET (V-μsec) for the application, divide by ET<sub>100</sub> from the table, and multiply by 100.
  - Limit the DC bias (H) to 46 orsted. Calculate H by multiplying H<sub>1</sub> from the table by I<sub>DC</sub> of the application.
  - Optional Tape & Reel packaging can be ordered by adding a "T" suffix to the part number (i.e. PL8500 becomes PL8500T). Pulse complies to industry standard tape and reel specification EIA481.

## Mechanical

## Schematic

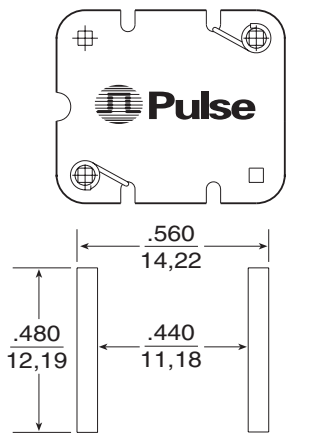

SUGGESTED PAD LAYOUT

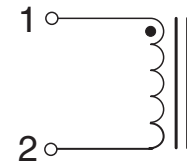
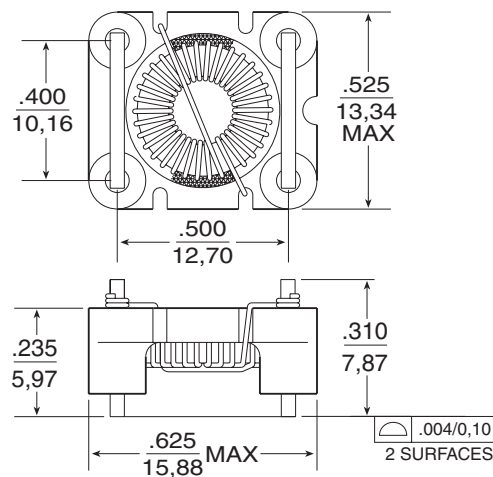

Pan & Tube ..... .35/tube  
Tape & Reel ..... .300/reel  
MSL ..... .3

Dimensions: Inches  
mm

Unless otherwise specified,  
all tolerances are ±  $\frac{.010}{0.25}$

## For More Information:

**Pulse Worldwide Headquarters**  
2 Pearl Buck Court  
Bristol, PA 19007  
U.S.A.  
[www.pulseeng.com](http://www.pulseeng.com)  
TEL: 215 781 6400  
FAX: 215 781 6403

**Pulse Northern Europe**  
3 Huxley Road  
Surrey Research Park  
Guildford, Surrey GU2 5RE  
United Kingdom  
TEL: 44 1483 401700  
FAX: 44 1483 401701

**Pulse Southern Europe**  
Zone Industrielle  
F-39270  
Orgelet  
France  
TEL: 33 3 84 35 04 04  
FAX: 33 3 84 25 46 41

**Pulse China Headquarters**  
No. 1  
Industrial District  
Changan, Dongguan  
China  
TEL: 86 769 5538070  
FAX: 86 769 5538870

**Pulse North China**  
Room 1002  
No. 819  
Nanjing West Rd  
Shanghai  
China  
TEL: 86 21 32181071  
FAX: 86 21 32181396

**Pulse South Asia**  
150 Kampong Ampat  
#07-01/02  
KA Centre  
Singapore 368324  
TEL: 65 6287 8998  
FAX: 65 6280 0080

**Pulse North Asia**  
3F-4, No. 81, Sec. 1  
Hsin Tai Wu Road  
Hsi-Chih  
Taipei Hsien  
Taiwan  
TEL: 886 2 26980228  
FAX: 886 2 26980948

Performance warranty of products offered on this data sheet is limited to the parameters specified. Data is subject to change without notice. Other brand and product names mentioned herein may be trademarks or registered trademarks of their respective owners.

© Copyright, 2005. Pulse Engineering, Inc. All rights reserved.

[www.pulseeng.com](http://www.pulseeng.com)

M113.A (10/05)