

SMT POWER INDUCTORS

Toroid - Military/Aerospace POGO Series



- Ruggedized header with POGO pins for secure board mounting
- Current Rating:** up to 14.4ADC
- Inductance Range:** 1.5µH to 139µH

Electrical Specifications @ 25°C — Operating Temperature -40°C to +130°C

Part Number ^{8,9}	Inductance @ I _{rated} (µH)	I _{rated} (A)	DCR (TYP) (mΩ)	ET (V-µsec)	Storage Capacity (µJoules)	Inductance @ 0ADC (µH ±20%)	100 Gauss ET ₁₀₀ (V-µsec)	1 Amp DC H ₁ (Orsted)	Connection
POGO 40									
PL8700	1.5	14.40	4.41	4.80	159.01	2.2	1.71	3.77	Parallel
PL8701	2.4	9.40	6.54	6.00	152.83	3.5	2.14	4.71	Parallel
PL8702	4.2	8.10	10.47	7.85	142.57	5.9	2.78	6.12	Parallel
PL8703	5.8	6.80	14.94	9.05	133.80	7.9	3.21	7.06	Parallel
PL8700	6.1	7.20	17.60	9.60	159.01	9.0	3.42	7.53	Series
PL8704	7.6	5.70	20.99	10.25	124.18	10.1	3.64	8.00	Parallel
PL8701	9.7	5.60	26.20	12.00	152.83	14.0	4.28	9.42	Series
PL8705	12.1	5.20	23.24	13.85	176.62	18.5	4.92	10.83	Parallel
PL8702	17.0	4.10	41.90	15.70	142.57	23.7	5.56	12.24	Series
PL8706	18.0	4.20	38.15	16.50	174.26	27.4	5.99	13.18	Parallel
PL8703	23.1	3.40	59.70	18.10	133.80	31.5	6.42	14.12	Series
PL8707	27.0	3.30	53.21	20.50	169.14	40.5	7.27	16.01	Parallel
PL8704	30.6	2.85	84.00	20.50	124.18	40.5	7.27	16.01	Series
PL8708	34.8	2.30	73.89	22.50	156.47	50.5	8.13	17.89	Parallel
PL8705	48.5	2.70	93.00	27.70	176.62	74.1	9.84	21.66	Series
PL8706	72.0	2.20	152.60	33.00	174.26	109.8	11.98	26.36	Series
PL8708	139.1	1.50	295.60	45.00	156.47	202.2	16.26	35.78	Series
PL8707	108.0	1.77	212.80	41.00	169.14	161.8	14.55	32.01	Series

NOTES:

- The reference inductance is a typical value at the AC and DC excitation listed.
- Temperature rise is 55°C in typical buck or boost circuits at 100kHz and with the reference ET applied to the inductor.
- Total loss in the inductor is 634mWatts for a 55°C temperature rise above ambient.
- To estimate temperature rise in a given application, determine copper and core losses, divide by 634 and multiply by 50.
- For the copper loss, calculate $I_{bc}^2 X R_n$.
- For core loss (mW), using frequency (f in Hertz) and operating flux density (B in Gauss), calculate $2.24 \times 10^{-10} \times B^{2.11} \times f^{1.26}$.
- For flux density (B), calculate ET (V-µsec) for the application, divide by ET₁₀₀ from the table, and multiply by 100.
- Optional Tape & Reel packaging can be ordered by adding a "T" suffix to the part number (i.e. PL8700 becomes PL8700T). Pulse complies to industry standard tape and reel specification EIA481.

Mechanical

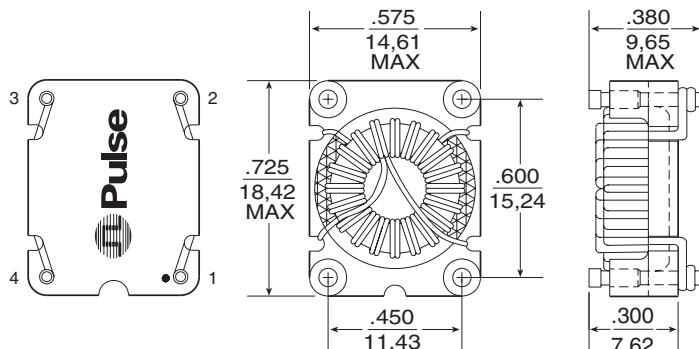

SUGGESTED PAD LAYOUT

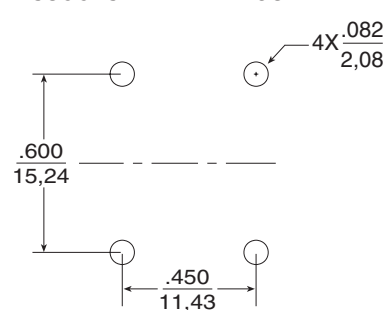

Schematic

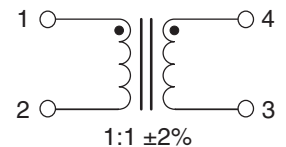

Pan & Tube30/tube
 Tape & Reel300/reel
 MSL3

Dimensions: $\frac{\text{Inches}}{\text{mm}}$

Unless otherwise specified, all tolerances are $\pm .010$
 0.25

For More Information:

Pulse Worldwide Headquarters

2 Pearl Buck Court
 Bristol, PA 19007
 U.S.A.
www.pulseeng.com
 TEL: 215 781 6400
 FAX: 215 781 6403

Pulse Northern Europe

3 Huxley Road
 Surrey Research Park
 Guildford, Surrey GU2 5RE
 United Kingdom
 TEL: 44 1483 401700
 FAX: 44 1483 401701

Pulse Southern Europe

Zone Industrielle
 Orgelet
 France
 TEL: 33 3 84 35 04 04
 FAX: 33 3 84 25 46 41

Pulse China Headquarters

No. 1
 Industrial District
 Changan, Dongguan
 China
 TEL: 86 769 5538070
 FAX: 86 769 5538870

Pulse North China

Room 1002
 No. 819
 Nanjing West Rd
 Shanghai
 China
 TEL: 86 21 32181071
 FAX: 86 21 32181396

Pulse South Asia

150 Kampong Ampat
 #07-01/02
 KA Centre
 Singapore 368324
 TEL: 65 6287 8998
 FAX: 65 6280 0080

Pulse North Asia

3F-4, No. 81, Sec. 1
 Hsin Tai Wu Road
 Hsi-Chih
 Taipei Hsien
 Taiwan
 TEL: 886 2 26980228
 FAX: 886 2 26980948

Performance warranty of products offered on this data sheet is limited to the parameters specified. Data is subject to change without notice. Other brand and product names mentioned herein may be trademarks or registered trademarks of their respective owners.

© Copyright, 2005. Pulse Engineering, Inc. All right reserved.

www.pulseeng.com